

Operating Manual

Overhead Line Measuring Set

CONSULTATION WITH MEGGER

The present system manual has been designed as an operating guide and for reference. It is meant to answer your questions and solve your problems in as fast and easy a way as possible. Please start with referring to this manual should any trouble occur.

In doing so, make use of the table of contents and read the relevant paragraph with great attention. Furthermore, check all terminals and connections of the instruments involved.

Should any question remain unanswered, please contact:

Megger Limited

Archcliffe Road
Kent CT17 9EN

T: +44 1304 502100

F: +44 1304 207342

E: uksales@megger.com

Seba Dynatronic

Mess- und Ortungstechnik GmbH

Dr.-Herbert-lann-Str. 6
D - 96148 Baunach

T: +49 9544 68 – 0

F: +49 9544 22 73

E: sales@sebakmt.com

Hagenuk KMT

Kabelmesstechnik GmbH

Röderaue 41
D - 01471 Radeburg / Dresden

T: +49 35208 84 – 0

F: +49 35208 84 249

E: sales@sebakmt.com

Megger USA

Valley Forge Corporate Centre
2621 Van Buren Avenue
Norristown, PA 19403 USA

T: +1 610 676 8500

F: +1 610 676 8610

© Megger

All rights reserved. No part of this handbook may be copied by photographic or other means unless Megger have before-hand declared their consent in writing. The content of this handbook is subject to change without notice. Megger cannot be made liable for technical or printing errors or shortcomings of this handbook. Megger also disclaim all responsibility for damage resulting directly or indirectly from the delivery, supply, or use of this matter.

TERMS OF WARRANTY

Megger accept responsibility for a claim under warranty brought forward by a customer for a product sold by Megger under the terms stated below.

Megger warrant that at the time of delivery Megger products are free from manufacturing or material defects which might considerably reduce their value or usability. This warranty does not apply to faults in the software supplied. During the period of warranty, Megger agree to repair faulty parts or replace them with new parts or parts as new (with the same usability and life as new parts) according to their choice.

Megger reject all further claims under warranty, in particular those from consequential damage. Each component and product replaced in accordance with this warranty becomes the property of Megger.

All warranty claims versus Megger are hereby limited to a period of 12 months from the date of delivery. Each component supplied by Megger within the context of warranty will also be covered by this warranty for the remaining period of time but for 90 days at least.

Each measure to remedy a claim under warranty shall exclusively be carried out by Megger or an authorized service station.

To register a claim under the provisions of this warranty, the customer has to complain about the defect, in case of an immediately detectable fault within 10 days from the date of delivery.

This warranty does not apply to any fault or damage caused by exposing a product to conditions not in accordance with this specification, by storing, transporting, or using it improperly, or having it serviced or installed by a workshop not authorized by Megger. All responsibility is disclaimed for damage due to wear, will of God, or connection to foreign components.

For damage resulting from a violation of their duty to repair or re-supply items, Megger can be made liable only in case of severe negligence or intention. Any liability for slight negligence is disclaimed.

EC Declaration of Conformity**CE**

We, the company

Hagenuk KMT
Kabelmesstechnik GmbH
Roederaue
D-01471 Radeburg
Germany

Declare under sole responsibility that our product

Connection terminal 40 A

Overhead Line Measuring Set with Pulse Booster

is in conformity with the directive of the Council of European Communities for the Harmonization of the Laws of Member States on Electromagnetic Compatibility (EMC directive 89/336/EEC).

This EC declaration of conformity is the result of a verification test performed by the department of Quality Assurance of Hagenuk KMT Kabelmesstechnik GmbH according to clause 10 of the regulation in line with the basic technical standards

- EN 50081-1 Emissions
- EN 50082-2 Immunity
- EN 55011 product standard.

Conformity with the Directive on Low Voltage was verified according to the following standards: EN 61010-1 Safety Precautions for Electrical Measuring, Control, Regulating and Laboratory Instruments as well as EN 60529 Protection by Enclosures.

Radeburg, 16.06.2003

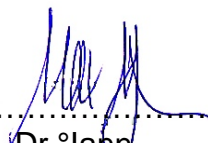

.....
Dr.°lann
Managing Director

SAFETY PRECAUTIONS

Each person involved in the assembly, operation, maintenance and repair of this device is required to have read this manual with care.

The System and its accessories are in accordance with the state of the art in safety engineering at the time of delivery. In the course of operations, however, there may be parts of the system and its peripherals which cannot be given optimum protection without unreasonably interfering with their operation and usability. This is why comprehensive personal experience in safety matters is vital for protecting both the staff and the system.

THEREFORE, ALWAYS ABIDE BY THE FOLLOWING SAFETY PRECAUTIONS!

GENERAL INSTRUCTIONS

Only trained or instructed staff are permitted to work on the device and its peripherals. Keep any other persons away from it.

This manual shall be permanently available to the supervisory, operating, and maintenance staff for reference.

Improper use may constitute a high risk of damage to life and limb, the device and any instrumentation connected to it, and the efficient operation of device (UVV, German Prevention of Accidents Regulation). This is why you are only allowed to employ the System to the purpose it has been designed for by its manufacturer.

Make sure your tools are in good working order when you work on the system.

Permanently supervise the observance of all safety instructions during operation and maintenance.

Only authorised persons with sufficient expertise are permitted to operate the device.

Make sure that the System and its peripherals are in good working order when being used.

Never use any foreign parts on the Compact System and its peripherals, otherwise the necessary degree of safety cannot be ensured. Do not carry out any operation which may jeopardise the safety of the Compact System.

The operator is required to immediately report any changes in the Compact System to the supervisor in charge.

The operator is required to shut the device down without delay whenever some malfunction occurs which may jeopardise the safety of the staff. The Compact System must not be put into operation again unless the fault has been remedied.

MARKUING USED IN THIS DOCUMENT

Important instructions concerning the protection of staff and property as well as technical safety are marked in the following manner:



Warning indicates working and operating procedures which shall be complied with in full to exclude any risk to persons. This includes reference to specific risks involved in the handling of the device.

ELECTROTECHNICAL PRECAUTIONS



Connect the device and its peripherals according to instructions. Make sure that the relevant **DIN**, **VDE** and **BGV**-regulations are observed.

Any repair and maintenance operations may be carried out only after the system has been switched off (is dead) and only by a skilled electrician according to UVV (Prevention of Accidents regulation). A person is regarded a skilled electrician to UVV if due to his or her training, knowledge and experience as well as knowledge of relevant regulations, he or she is able to assess the job to be carried out and detect any possible risk.

Dealing with high voltage equipment and systems requires special attention. Absolutely comply with DIN VDE Regulation 0104 "Installation and Operation of Electrical Test Equipment" or equivalent IEC standards. Also comply with DIN VDE Regulation 0105-100 "Operation of Electrical facility".

For the time of operation at least two persons must be present, with one of them having immediate access to the emergency-off switch.

CONTENTS

1	TECHNICAL DESCRIPTION.....	1-13
1.1	INTENDED APPLICATION	1-13
1.2	APPLICATION	1-13
1.3	PRODUCT VERSIONS	1-15
1.4	TECHNICAL DATA OF THE OVERHEAD LINE MEASURING SET ...	1-15
1.5	SCOPE OF DELIVERY AND ACCESSORIES.....	1-17
2	OPERATING INSTRUCTIONS.....	2-21
2.1	TERMINALS AND CONTROLS OF THE CONNECTIONS BOX.....	2-21
2.2	CONNECTION TO TEST OBJECT	2-24
2.2.1	PROBLEMS WHEN MAKING CONNECTION TO A HIGH-VOLTAGE OVERHEAD LINE.....	2-25
2.2.2	SPECIAL ISSUES WHEN CONNECTING TO HVDC SYSTEMS	2-25
2.2.3	PRINCIPLE OF HOW TO SEPARATE INDUCED MAINS COMPONENTS FROM THE TRANSMITTER PULSE	2-26
2.2.4	MAKING THE CONNECTION	2-28
2.3	MEASUREMENT.....	2-32
2.3.1	TAKING INTO ACCOUNT LINE SAG.....	2-32
2.3.2	PASSIVE OR ACTIVE MEASUREMENT	2-33
2.3.3	PULSE GENERATED BY THE INTERNAL PULSE GENERATOR.....	2-34
2.3.4	HF-FILTER	2-34
2.3.5	HOW TO TAKE THE CONNECTION CABLE INTO ACCOUNT.....	2-34
2.3.6	RECORDING THE “FINGERPRINT” OF A LINE.....	2-35
2.3.6.1	PASSIVE MEASUREMENT.....	2-36
2.3.6.2	ACTIVE MEASUREMENT (INTERNAL PULSE GENERATOR REQUIRED).....	2-37
2.3.7	CARRYING OUT COMPARATIVE MEASUREMENTS.....	2-39
2.3.7.1	PASSIVE MEASUREMENT.....	2-40
2.3.7.2	ACTIVE MEASUREMENT (INTERNAL PULSE GENERATOR REQUIRED).....	2-41
3	CARE AND MAINTENANCE.....	3-45

ANNEX

APPENDIX 1 Differential Measurement

APPENDIX 2 Dependence of the Maximum Range from Pulse Width

Chapter 1

TECHNICAL DESCRIPTION

1 TECHNICAL DESCRIPTION

1.1 INTENDED APPLICATION

The Overhead Line Measuring Set is a qualified means for any user to identify impedance abnormalities in overhead lines.

It is, however, **only suitable for use on HVDC systems to a limited extent!** For this type of use, the specifications compiled in Section 2.2.2 must be observed. Otherwise, the connection box could be destroyed when connecting to a HVDC overhead line. This is caused by inductive interference's form parallel systems alive into the line under test. The behaviour is related to a special condition in HVDC systems coming from active harmonic tension superposition of the HVDC converter systems.

1.2 APPLICATION

Suitable pulses are transmitted into the line to be tested. These pulses will be reflected by any inhomogeneity (fault) on the line.

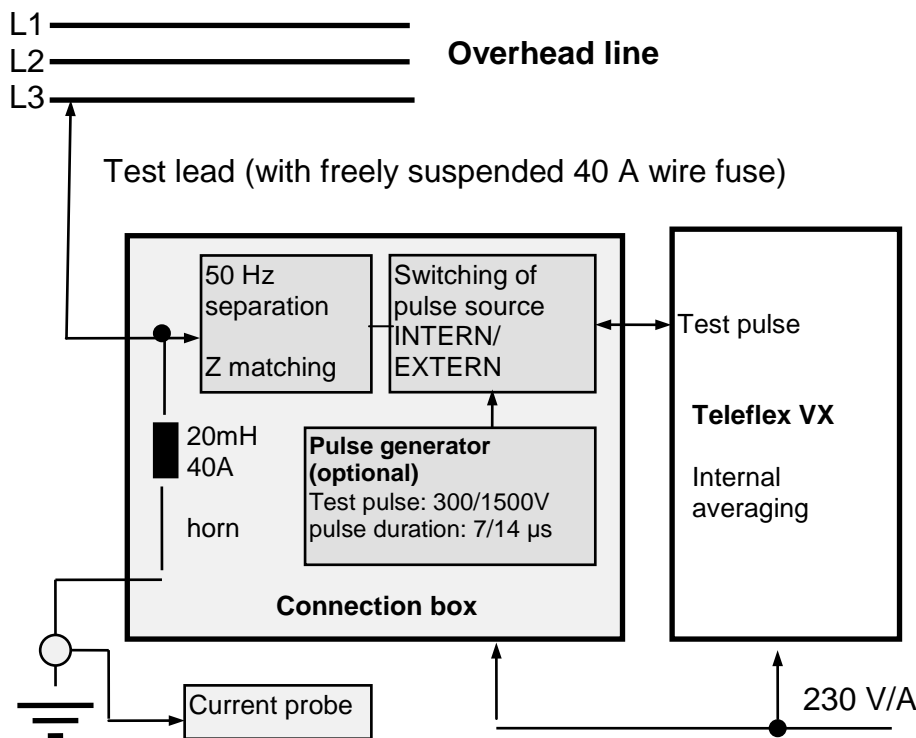

Fig 1 Overhead Line Measuring Set

The Teleflex VX Reflectometer is easy to operate and very quick in providing data of impedance irregularities on the overhead line. The reflectogram can be viewed on the screen for the full length of the line or for individual sections of interest.

The signal velocity of the pulses along the overhead line is roughly constant at 295 m/μs and thus only a little less than the speed of light $c = 299.79 \text{ m}/\mu\text{s}$.

$$295 \text{ m}/\mu\text{s} \Rightarrow v/2 = 147,5 \text{ m}/\mu\text{s} \Rightarrow \text{NVP} = v/c = 0,984$$

Passive Measurement

In passive mode, the measuring set is used as connection box only. The measuring pulses for the pulse reflection measurement are generated by the Teleflex VX. In this way, measurement on overhead lines up to a line length of about 300 km can be performed.

Active Measurement (product version with internal pulse generator)

If the overhead line is longer than 300 km, the internal pulse generator should be used instead. You have the choice of selecting a pulse power of ≥ 300 W or ≥ 7500 W and a half-power width of the transmitter pulse of 10 μ s or 20 μ s. With a characteristic impedance of the overhead line of 300 Ohm, the amplitude of the transmitted test pulse is approx. 300 V or 1500 V ($U_{pp} = \sqrt{P \times Z}$).

Starting from one end of the line, faults can be located over a distance of up to 1000 km, depending on the attenuation of the line. The high output power of the pulse generator with its high signal-to-noise ratio has a very positive effect on fault detection. If you want to test a line with heavily corroded junctions, select the higher transmitter amplitude so as to enable the pulse to overcome the corroded points.

Typical values of the characteristic impedance of an overhead line:

Un, kV	Number of strands	Z, Ohm
110	1	400
220	1	400
220	2	280
380	3	240
380	4	230
500	3	267
750	4	260

$$Z \approx \sqrt{L' / C'}$$

$$v \approx 1 / \sqrt{L' \times C'} < c \Rightarrow v \approx c / \sqrt{\epsilon_r}$$

Z	characteristic impedance	L'	inductance per km
C'	capacitance per km	v	signal propagation velocity
c	speed of light	ϵ_r	relative dielectric constant

1.3 PRODUCT VERSIONS

There are two versions of the Overhead Line Measuring Set. The **passive** version has no internal pulse generator and, thus, can only be operated with an external pulse source (Teleflex VX). The **active** version has its own internal pulse generator.

1.4 TECHNICAL DATA OF THE OVERHEAD LINE MEASURING SET

Mains voltage

Active version	230 VAC \pm 10%; 49 ... 61 Hz (\leq 70 VA)
Passive version	100 ... 240 VAC; 47 ... 63 Hz

Fuses

Active version	2 x 0.315 A / slow-acting
Passive version	2 x 0.16 A / slow-acting

Internal pulse generator (optional)

Test pulse power at mains voltage 230 VAC	rating \geq 300/7500 W corresponding to a test pulse peak voltage at $Z = 300 \Omega$ of \geq 300/1500 V
Half-power width of test pulse	10 μ s 20 μ s
Characteristic impedance at output	300 Ω
Number of test pulses per sec	\leq 2
Triggering	internally (pulses are triggered each 0.5 s) manually by key stroke (\leq 2 Hz) externally by L/H edge (H within range 3 ... 30 V; repetition frequency \leq 2 Hz)
Leakage current through choke	continuous operation 20 A short-term operation 30 min 21 ... 30 A short-term operation 10 min 31 ... 40 A Temperature of choking coil is monitored, limit 90°C 20 mH \pm 20% \leq 0.5 Ω
Overcurrent protector	40 A wire fuse in lead
Mode of connection	single-phase

Measuring range	up to 1000 km (with internal pulse generator)	
Filter pass-band range (≤ 3 dB)	filter	10 ... 2000 kHz
	filter 1 MHz	10 ... 1000 kHz
	filter 300 kHz	10 ... 300 kHz
	filter 100 kHz	10 ... 100 kHz
Environmental conditions		
Operating temperature	-25 °C ... +50 °C (without Teleflex VX)	
Storage temperature	-40 °C ... +70 °C (without Teleflex VX)	
Relative humidity	$\leq 93\%$ at 30°C	
Dimensions (L x W x H)	600 x 400 x 260 mm	
Weight	48 kg	
Interelement protection class	I to DIN VDE 0106 Part 1	
Enclosure protection	IP54 to EN 60529	
Electric safety	to DIN EN 61010-1	
Electromagnetic compatibility	to DIN EN 50081-1 and DIN EN 50082-2	

For the technical specification of the Teleflex VX, please refer to operating manual of the Teleflex VX.

Subject to change without notice!

1.5 SCOPE OF DELIVERY AND ACCESSORIES

Scope of Delivery:

Designation
<ul style="list-style-type: none">• Teleflex VX• Connection box (with optional pulse generator)• Earthing system 5 m, made up of:<ul style="list-style-type: none">- earth wire 5 m- earth lead 5 m- auxiliary earth lead 5 m• Connection box <-> Teleflex VX connection cable• Telescope-type earthing rod with cable guide + feeder clamp• 6 x protective resistor (wire fuse)• Connecting lead with coupling• Earthing clamp• Current probe for measuring the leakage current• Trolley bag for accessories

Subject to change without notice!

Chapter 2

OPERATING INSTRUCTIONS

2 OPERATING INSTRUCTIONS

2.1 TERMINALS AND CONTROLS OF THE CONNECTIONS BOX

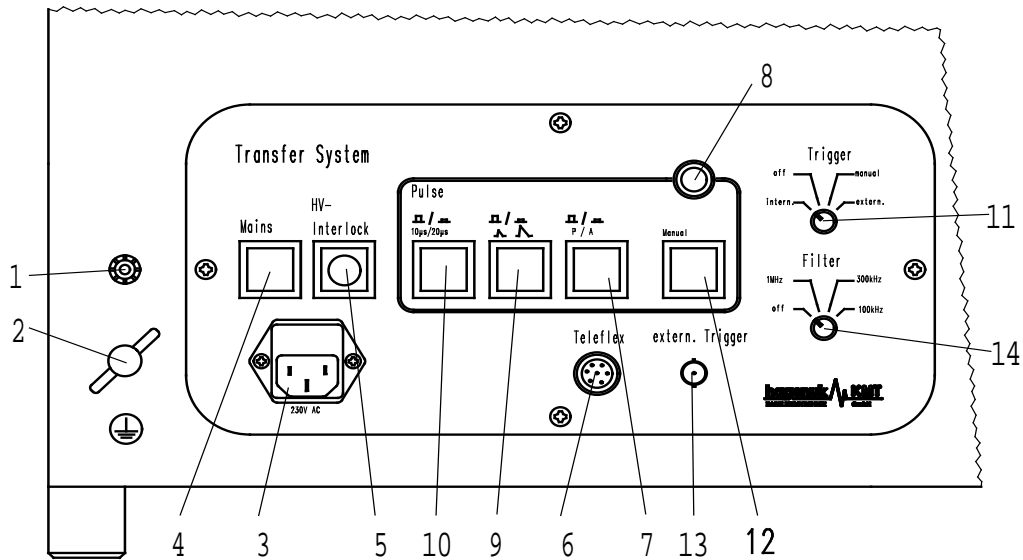

Fig 2 Front view of the connection box with integrated pulse generator

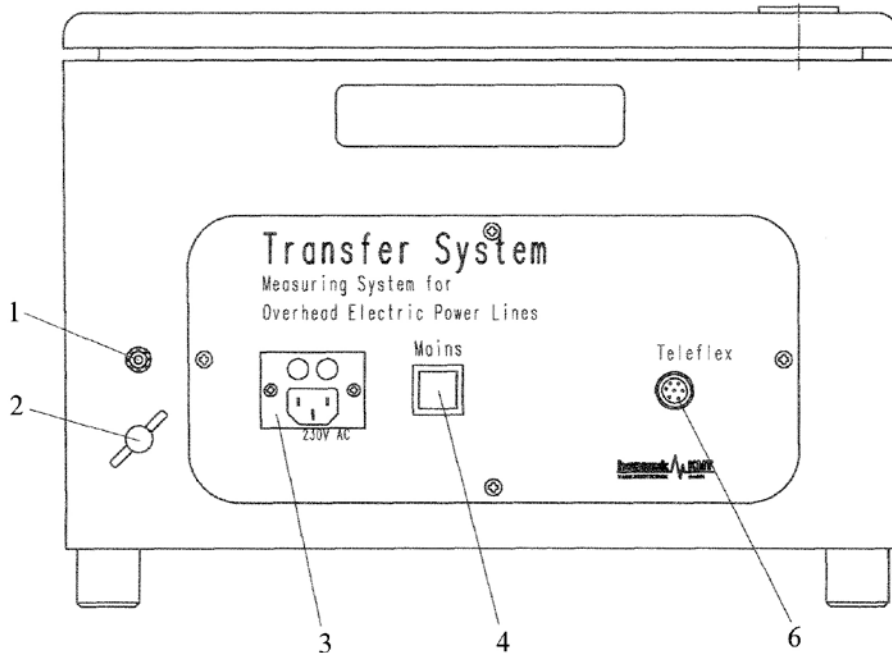

Fig 3 Front view of the connection box without integrated pulse generator

Element	Description
1	Socket for additional earth connection (auxiliary earth)
2	Screw terminal for additional earth connection (auxiliary earth)
3	Mains socket 230 V $\pm 10\%$; 49 ... 61 Hz; Fuses: 0.315 A slow-acting
4	If the "Mains" lamp is green, mains voltage is applied and temperature monitoring of the choking coil is enabled.
5	Switch key. Switch HV-Interlock on, if you want to operate the test set in "active mode" (using the internal pulse generator).
6	Feed the test signal via socket "Teleflex" through the cable connected to it to Reflectometer Teleflex VX.
7	<p>Passive („P“) / Aktive („A“) pushbutton</p> <p>If the switch is not depressed, "Passive" mode is enabled. The pushbutton and the LED (8) are off. In this mode, pushbuttons 9, 10, 11, 12 and 14 may be in any position. The test pulses are generated by the Teleflex VX.</p> <p>If the switch is depressed, the test set is working in "Active" mode and the switch lamp is lit. In this mode, the pushbuttons 9, 10, 11, 12 and 14 have to be set as described below.</p>
8	Trigger LED (flashes whenever a pulse is released by the internal pulse generator)
9	<p>Pulse amplitude</p> <p>pressed: 1500 V not pressed: 300 V</p>
10	<p>Pulse width</p> <p>pressed: 10 μs not pressed: 20 μs</p>
11	<p>Trigger mode</p> <p>off no pulse is released</p> <p>intern. pulses are automatically released by the internal generator at a rate of 2 Hz (red LED flashes with any pulse)</p> <p>manual the red „Manual“ pushbutton (12) is lit; a pulse can be triggered by pressing the pushbutton (≤ 2 Hz) (red LED flashes with any pulse)</p> <p>extern. apply trigger signal to BNC socket (13); with each L/H slope of the trigger signal (repetition rate ≤ 2 Hz) a test pulse is generated and the red LED flashes</p>

12	Pushbutton for manual pulse triggering (switch 11 must be set to “manual” position).
13	BNC socket for connecting an external trigger device.
14	The "Filter" switch allows the interference by HF signals to be suppressed by enabling a low-pass filter with an upper cut-off frequency of 2000 kHz, 1000 kHz, 300 kHz or 100 kHz.

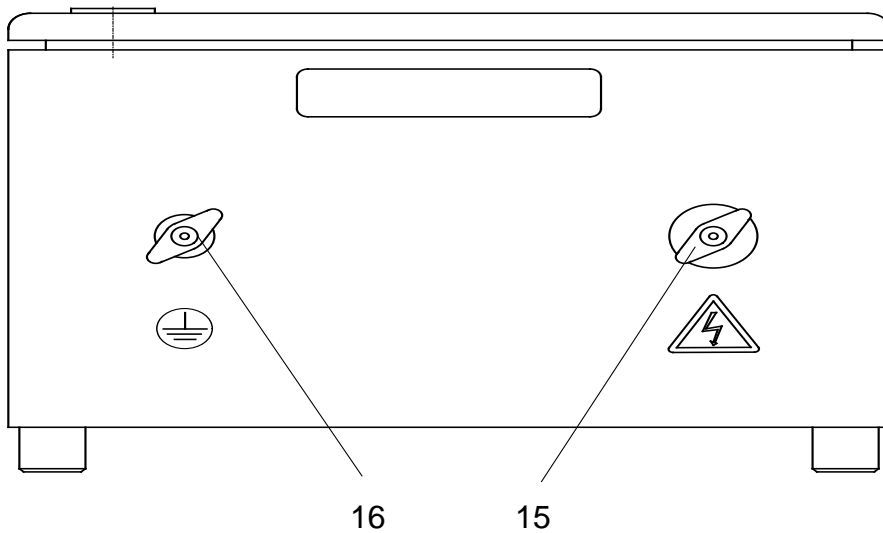

Fig 4 Rear view of the connection box

Element	Description
15	Red clamp; connection to overhead line
16	Black clamp; earth connection

2.2 CONNECTION TO TEST OBJECT

**WARNING**

It is absolutely vital for the safety of the operator and the equipment to make the connection correctly and with great care.

- The safety guidelines for the operation of mobile test systems often differ from one network operator to another and are frequently subject to national regulations (such as the German BGI 5191). Before the measurement session, find out what the applicable guidelines are and follow the rules set out therein precisely, in respect of the organisation of work and the commissioning of the mobile test system!
- Select a location which is sufficient for the weight and size of the system and ensures that it stands securely.
- Safety installations may not be by-passed nor deactivated.
- When using the overhead line measuring set on HVDC stations, the specifications described in Section 2.2.2 - must be observed.

2.2.1 PROBLEMS WHEN MAKING CONNECTION TO A HIGH-VOLTAGE OVERHEAD LINE

After having been disconnected, each high-voltage overhead line may carry induced voltage (when point of connection is open) or induced current (when point of connection is earthed) the intensity of which may be considerable. Moreover the electric energy which is introduced via capacitance must not be neglected, too. This voltage or current introduced as mentioned may be quite dangerous. Their intensity is dependent on a number of factors. Some of them are:

- Voltage of the neighbouring system
- Load of the neighbouring system
- Length of the disconnected system
- Structure of the system (distance etc., any twisting of wires within a system will in general reduce mutual influences to a large degree.)

The current flows through the earth clamps of the connection box and is conducted to the station earth through the earth wire. Additionally, the overhead line measuring set is connected to the protective ground over the protective conductor of the mains cable. Therefore you have to keep in mind that the remedial current must not rise over 10 A. If the safety earth must not be connected to station earth or if the current is greater than 10 A, you have to operate the overhead line measuring set with an isolating transformer.

When making the connection the task has to be solved that the connection box and the Teleflex VX are matched with the overhead line to be tested in an optimal way and that any voltage or current induced as mentioned above will not constitute a risk to the operator and the system.

2.2.2 SPECIAL ISSUES WHEN CONNECTING TO HVDC SYSTEMS

In general, the overhead line measuring set was designed for measurement of overhead lines that are operated with three-phase AC power. To also ensure the safety of people and equipment when measuring HVDC systems, the following specifications must be observed:

- The entire HVDC system (both poles) must be deactivated.
- The converters must be switched off completely (not standby).
- Existing parallel systems must be switched off. At the start and end point, no additional HVDC systems may be on operation.
- The overhead line is electrically disconnected from the converters.
- The opposite side of the overhead line must be grounded.

Even when these specifications are fulfilled, the quality of the TDR traces can be influenced by other confounding factors.

2.2.3 PRINCIPLE OF HOW TO SEPARATE INDUCED MAINS COMPONENTS FROM THE TRANSMITTER PULSE

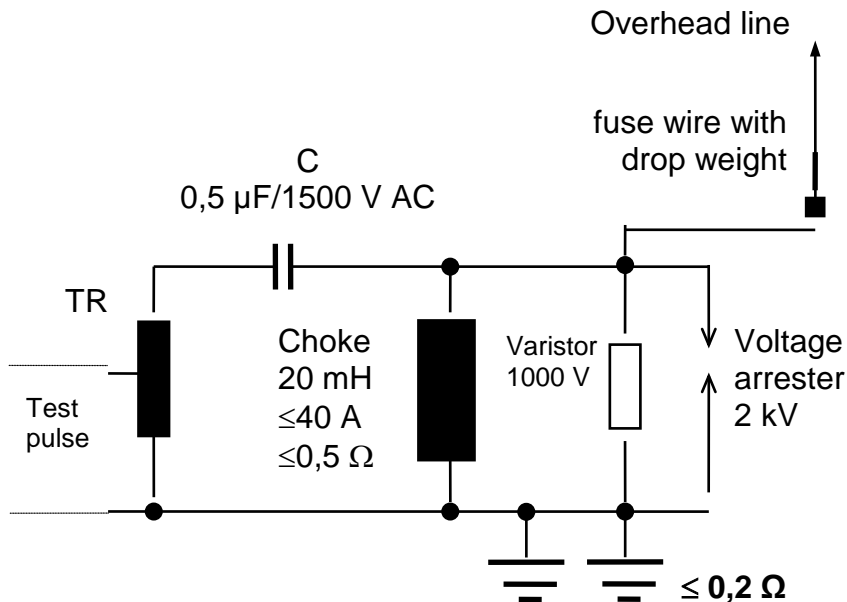

Fig 5: Principle block diagram

The components are for the following purpose:

- The choke is a relatively low-resistance earth connection ($Z \approx 0.4 + j6.28$ at 50 Hz). Thus any mains component coupled into the overhead line through induction or capacitive paths are arrested to earth. The inductance of the choke coil is great enough, however, to ensure that the transmitter pulse and the reflections are not much influenced. In parallel to the earthing choke there is a 1000 V varistor and a 2 kV voltage arrester which serve as protectors against surge and travelling waves. The continuous current through the choke must not exceed ≤ 20 A. When the green lamp (4) at the connection box is lit, the temperature of the choke is being monitored. A horn is sounded as soon as the outside temperature of the choke exceeds 90°C. In such case the earth connector of the overhead line on the test site has to be closed.
- The size of the coupling capacitance 0.5 µF is such that the pulse and the reflections will not be influenced to a large degree whereas 50 or 60 Hz, respectively will be attenuated heavily.
- The pulse transformer TR is for matching the characteristic impedance of the overhead line (230 - 400 Ω) to the characteristic impedance of the test equipment (50 Ohm).

It is of outstanding importance that there is a low-resistance connection ($\leq 0.2 \Omega$) from the choke to earth. For safety reasons this connection has to be made twofold.

Lay out earthing cable number 1 between the black connecting terminal (16) and low-resistance earth. Safely connect the second cable (earthing cable number 2) to the silver connecting terminal (1 or 2) and low-resistance earth (remove any soiling or oxidation from the earth connection points). When laying out the cables make sure that the contacts are screwed tightly. Also make sure that there is no potential difference between both low-resistive earthing points.

Use a flying line to connect the overhead line to the connection box (red terminal - 15). At the end of the stranded wire to be connected to the overhead line there is a 2 m resistance wire. The resistance wire will melt off as soon as the current is too great thus protecting the earthing choke against overload. This kind of protection is effective for high-energy surge waves, too. Please arrange the connection in a way that in any case of fault the drop weight (the bolt which connects the two lines) has enough clearance to fall down freely thus ensuring a wide enough air gap between the overhead line and the fused point. Moreover please make sure that the dropping weight will not cause any damage.

Lay out all cables in such a way that there is no risk of the cables being torn off unintentionally. Position your overhead line test equipment outside the danger zone.

2.2.4 MAKING THE CONNECTION

 WARNING	<p>Make sure that the task of connecting the overhead line test equipment to the high-voltage overhead line is only assigned to persons who are familiar with the safety regulation for high-voltage plants and who are entitled to enter the high-voltage area (danger zone). The competent user departments are required to carry out regular instructions about the relevant regulations and the <u>risks arising from non-observance of these regulations.</u></p>
---	--

Please abide by the following course of procedures when putting up your equipment and making connection:

1. The overhead line to be measured is to be isolated and grounded as close to the point of connection as possible. When connecting to an HVDC system, the specifications summarised in Section 2.2.2 must be observed! Wait for the disconnected status message!

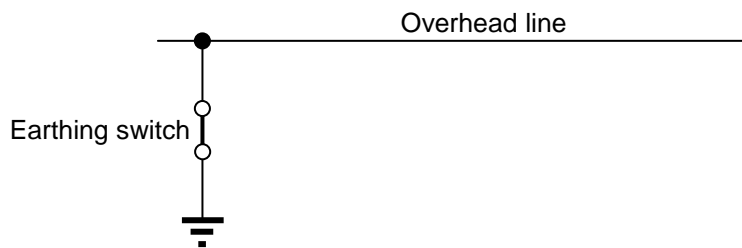

2. After the all-clear for the danger zone has been given: Position the connection box with its arrester choke near the intended place of connection and **safely connect it to earth ($\leq 0,2 \Omega$)**.
 - Polished earth wire thimble connect to black clamp (16) and to station earth
 - Earth lead (yellow/green) thimble connect to clamp 1 or 2 and to station earth

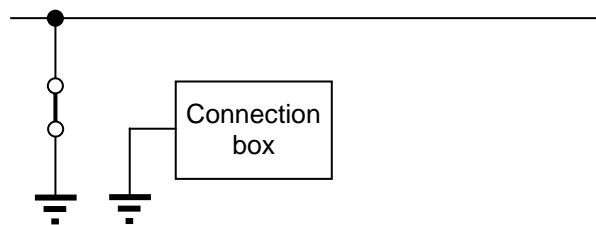

 WARNING	<p>Always connect earthing cable (main earth) first and disconnect it last!</p>
---	---

3. If available, a current probe (can be ordered as optional accessory) should be connected to one of the earth cables. In this way, the compensating current flowing through the ground connection (which should not exceed 10 A) can be observed during measurement.
4. Make the connection from the connection box (socket 6) to the Teleflex VX.

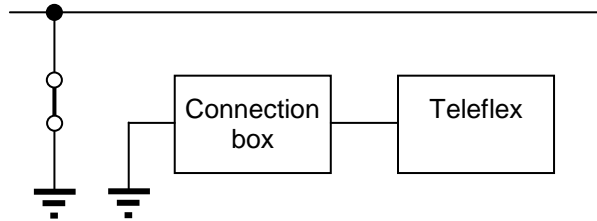

5. Connect the connection box (socket 3) and the Teleflex VX to mains (230 V $\pm 10\%$; 49 ... 61 Hz).

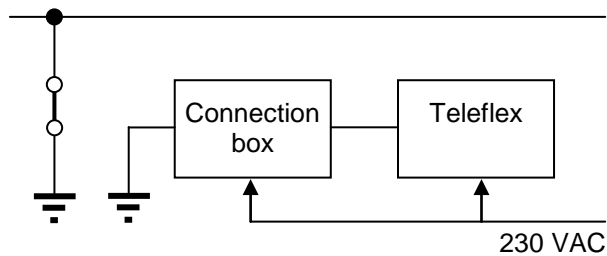

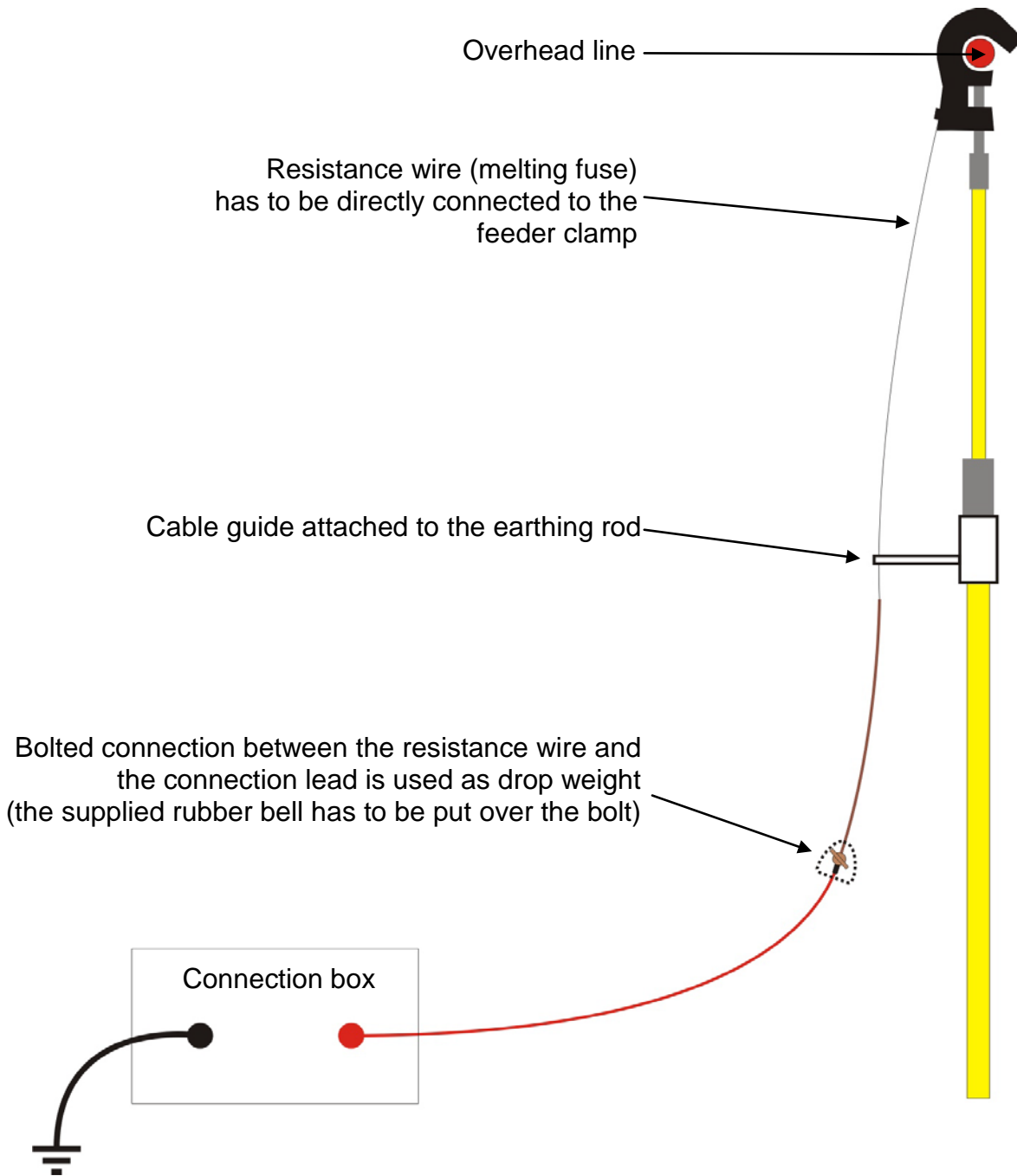

6. Make the connection from the overhead line to the connection box (clamp 15).

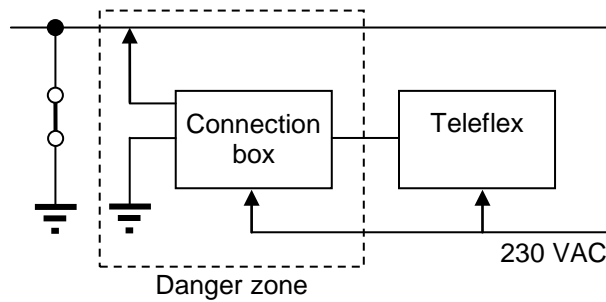

The red line must not get into contact with earth. In no event reel it (L)! This may render the measurement results useless.

7. Check all connections once again with great care. Make absolutely sure that in no event a connection can be torn off while the test is running.



 WARNING	<p>After all connections have been checked, leave the danger zone and protect it against being entered unintentionally</p>
---	--

8. The earth connection of the overhead line to be tested (earthing switch) can be removed only shortly before the test is started and shall be re-established immediately after the test has been finished.

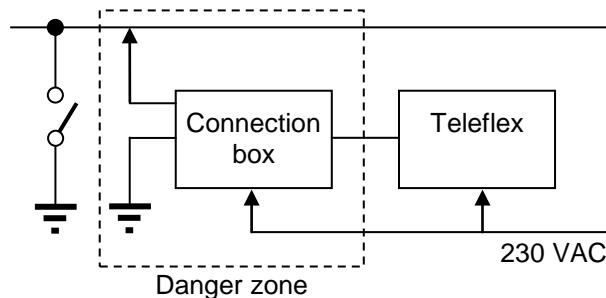

 WARNING	<p>DANGER TO LIFE!!</p> <p>Consider the connection box and the connection cable as being under voltage for as long as it is connected to the overhead line and the earthing facility (earth switch) is not closed. The same applies to the period when test pulses are transmitted.</p>
---	--

Note: The far end of the overhead line can remain earthed. This increases both the safety and the signal quality. In this case, the end of the line shows up as a short circuit in the TDR trace. For measurements on HVDC systems, the opposite side must remain grounded!

For dismantling the overhead line test site, please follow the steps mentioned above in inverse order and strictly abide by all safety regulations. (Time shall be allowed for the fuse wire to cool down.)

2.3 MEASUREMENT

 WARNING	DANGER TO LIFE !! If the horn sounds during measurement, the choke coil has overheated due to overcurrent. In this case, the earthing switch must immediately be closed at the location of the measurement. It is strictly forbidden to enter the danger zone or to touch parts of the measuring system!
---	--

Note: If the leakage current through the choke is too high, try to reduce it by switching off all systems (other overhead lines) running in parallel to the overhead line under test.

2.3.1 TAKING INTO ACCOUNT LINE SAG

Due to sagging of overhead lines, the line length that can be seen in the line diagram differs from the actual cable length by an amount in the single-digit percentage range.

To counteract this effect and also to be able to read the geographic distances on the reflectometer, a correction should be made using the propagation velocity.

To do this, you need to mark a conspicuous impedance change in the reflectogram, and its cause should be able to be unambiguously assigned to an item in the line diagram (such as the end of the line). Then you should adjust the propagation velocity $V/2$ until the displayed distance specification matches the actual geographic distance.

The propagation velocity of 147.5 m/ μ s represents a suitable average for overhead lines and takes into account sagging of the overhead line with 1.666%. Under certain circumstances it may be necessary to make corrections of approx. 0.5%.

2.3.2 PASSIVE OR ACTIVE MEASUREMENT









For the product version with an integrated pulse generator, you can always choose between active measurement with the measurement pulses of the internal pulse generator and passive measurement with the measurement pulses of the Teleflex VX.

For short and medium line lengths of up to 300 km (and often beyond this), we recommend that you measure in passive mode, since the pulse parameters set in the Teleflex VX are automatically saved with the recorded traces. This makes operation much easier in case of a subsequent comparative measurement.

With lengths of approx. 300 km and up, it can make sense to use the internal pulse generator, whose measurement pulses have higher amplitude. In case of strong parasitic induction, the higher amplitudes of the measurement pulses of the internal pulse generator can lead to better results even on short lines.

In case of doubt, you should determine the operating mode suitable for a line by comparing both measurement modes.

Suggested operation mode and pulse settings:

Fault distance	Teleflex VX		Connection box		
	Mode	Pulse width	Mode switch (7)	Pulse amplitude Z=300 Ω switch (9)	Pulse width switch(10)
0 ... 1 km	 INT	20 ... 100 ns	P	-	-
1 ... 10 km	 INT	200 ... 500 ns	P	-	-
10 ... 30 km	 INT	500 ns ... 1 μs	P	-	-
30 ... 100 km	 or  INT	1 μs ... 2 μs	A or P	300 V	10 μs
100 ... 300 km	 or  INT	5 μs ... 10 μs	A or P	1500 V	10 μs
>300km		-	A	1500 V	14 μs

2.3.3 PULSE GENERATED BY THE INTERNAL PULSE GENERATOR

Although the maximum pulse power of the optional integrated pulse generator is below the limit of danger to man (≤ 350 mJ) according to VDE0104 (EN 50191), it may have an unpleasant irritating effect on man. As a consequence, make sure that the connection box is switched on only after your test equipment has been put up completely.

2.3.4 HF-FILTER

Most high voltage overhead lines are utilised for HF telephony, too. Moreover they are very effective antennas and pick up HF signals from neighbouring transmitters. These HF voltages, preferably those in the medium and long-wave ranges, may considerably interfere with measurements. On the other hand, we advise you to be careful when using the filter, as the filter has some influence on how the test pulse and its reflections are represented. Amplitudes will be the smaller and rounder the lower the upper cut-off frequency. We advise you to find out the filter setting (switch 14) appropriate to each test by trying out.

2.3.5 HOW TO TAKE THE CONNECTION CABLE INTO ACCOUNT

For taking a measurement, a connection cable is used to connect the connection box to the overhead line. The delay time caused by the interconnect cable should be taken into account in order to reduce measurement errors as far as possible, in particular with relatively short test objects and long interconnect cables.

To determine the apparent length of the connection cable, close the earthing switch at the start of the overhead line. The Teleflex VX will then show a short-circuit echo that marks the start of the overhead line. The apparent length of the interconnect cable is measured using the propagation speed of the overhead ($v/2 = 147.5$ m/ μ s). Deduct this measured value from the distance indicated when subsequently taking a measurement. In this manner you will be able to determine the distance between the point of connection and the fault with high precision.

You may also be able to determine the apparent length between Teleflex VX and the connecting point to the overhead line with the overhead line already connected, as the transition from the interconnect cable to the overhead line will introduce a reflection of its own.

(When you deal with individual sections, you may add or deduct them only on condition that they have been measured with the same propagation speed. We advise you to calculate in terms of travel time when dealing with individual sections.)

2.3.6 RECORDING THE “FINGERPRINT” OF A LINE

For every overhead line for which you are responsible, a “fingerprint”, i.e. a reflectogram under normal conditions, should be recorded and saved. These reflectograms can be called up again when required and compared with the current trace curve. In this way significant changes in the impedance behaviour can be identified in seconds.

We recommend that you save a “fingerprint” for each of the four seasons in order to be able to exclude weather-related differences to the greatest extent possible when making a comparison.

It makes sense to evaluate the “fingerprint” immediately after it is recorded and use the line diagrams to determine abnormalities and their causes. These known points can then make any pre-location that may become necessary at a later point in time much easier.

The reflectogram will show any greater deviation from the characteristic impedance as a reflection. Any rise in the characteristic impedance will result in a positive reflection, any drop in a negative reflection. These variations in the characteristic impedance and reflections caused by them may be the results of, among other things, the following phenomena:

- Faults in the line system (e.g. interruption (+), short circuit or earth leakage (-))
- Line has come off an insulator ⇒ line sagging without contact to earth (negative reflection)
- Strong change in line direction ($\geq 30^\circ$)
- Transformer substation (mostly negative reflection)
- Transposition poles or towers (positive or negative reflection)
- End of line (open (+); connected to earth (-)). If the end of line can be recognized, the fault at shorter distance is obviously not complete (100%).
- Transition to a system of different construction (e.g. different line material)
- Crossing of overhead lines or railroad lines
- Crossing of a broad river (weak negative reflection due to the wider span and the resulting deeper sag as well as the change in medium below the overhead line (water in place of soil)).
- Vegetation





Install the Overhead Line Measuring Set according to section 2.2.4. A low-resistance and solid connection of the choking coil to earth is of particular importance. Severe danger to life and limb as well as to the equipment may arise if you do not follow the procedure described in section 2.2.

For how to operate the Teleflex VX, please refer to its accompanying instruction manual.

2.3.6.1 PASSIVE MEASUREMENT

Step	Action
1	Connect the connecting box to mains; green lamp lights up (temperature monitoring of the choking coil is enabled)
2	Leave the key switch of the connection box in OFF position and make sure the "P / A" pushbutton is not pressed (this step is only necessary for models with internal pulse generator).
3	Switch on the Teleflex VX.
4	Switch the Teleflex VX to $\frac{\text{T}}{\text{INT}}$ (TDR int) operation mode.
5	Select the „L1-N“ option from the phase selection menu of the Teleflex VX.
6	Configure the Teleflex VX as follows: <ul style="list-style-type: none"> • Set the Pulse width according to the table in section 2.3.2. • Set the Filter value to 450 kHz • Set the Compensation value to 50 Ω • Set the V/2 value to 147.5m/μs (see also section 2.3.1) • Enable Averaging • Set X Range 10% above line length
7	Start the measurement using the  menu item. The Teleflex VX now performs 256 successive measurements and constantly updates the trace shown on the display. This trace represents the average value of the traces recorded up to that point. The measurement then stops automatically.
8	Check the trace shown for abnormalities and try to assign them to their causes (see also page 2-35). Compare the distance specifications with the line diagrams and take note of the most important points. The trace is automatically saved to the history database. You can also add a comment (line name) to the database entry.

2.3.6.2 ACTIVE MEASUREMENT (INTERNAL PULSE GENERATOR REQUIRED)

Step	Action
1	Set "Trigger" switch (11) to "off" position
2	Connect the connecting box to mains; green lamp lights up (temperature monitoring of the choking coil is enabled)
3	Switch the key switch in „ON“ position and press the "P / A" pushbutton. The red "P / A" pushbutton lights up.
4	Select the pulse amplitude with the pushbutton (9). pressed: 1500 V not pressed: 300 V
5	Select the pulse amplitude with the pushbutton (10). pressed: 10 μ s not pressed: 20 μ s
6	Select the trigger mode using the „Trigger“ switch (11) intern. pulses are automatically released by the internal generator at a rate of 2 Hz (red LED flashes with any pulse) manual the red „Manual“ pushbutton (12) is lit; a pulse can be triggered by pressing the pushbutton (≤ 2 Hz) (red LED flashes with any pulse) extern. apply trigger signal to BNC socket (13); with each L/H slope of the trigger signal (repetition rate ≤ 2 Hz) a test pulse is generated and the red LED flashes
7	Switch on the Teleflex VX.
8	Switch the Teleflex VX to  (Overhead line) operation mode.
9	Select the „L1-N“ option from the phase selection menu of the Teleflex VX.
10	Configure the Teleflex VX as follows: <ul style="list-style-type: none"> • Set the Filter value to 450 kHz • Set the Compensation value to 50 Ω • Set Trigger threshold to 1 V • Set the V/2 value to 147.5 m/μs (see also section 2.3.1) • Enable Averaging • Set X Range 10% above line length
11	Start the measurement using the  menu item.
12	Depending on the selected trigger mode, trigger the pulse generator to release a pulse

13	<p>The Teleflex VX now records 256 successive reflectograms in time with the triggerings made and constantly updates the trace shown on the display. This trace represents the average value of the traces recorded up to that point.</p> <p>The trace is then frozen and further triggerings by the pulse generator are ignored.</p>
14	<p>Check the trace shown for abnormalities and try to assign them to their causes (see also page 2-35). Compare the distance specifications with the line diagrams and take note of the most important points.</p> <p>The trace is automatically saved to the history database. You can also add a comment (line name) to the database entry.</p>
15	<p>After measurement the settings which have been made on the front panel of the connection box can be entered into a dialog box appearing on the Teleflex VX display. In this way, the settings are stored together with the recorded trace in the history database of the Teleflex VX.</p>

2.3.7 CARRYING OUT COMPARATIVE MEASUREMENTS

Using comparative measurements carried out on a regular basis, changes in the impedance behaviour of an overhead line can be determined and their causes can be investigated. In this way looming problems (such as contamination due to birds building nests) can be detected at an early point in time and rectified without time pressure.

Comparative measurements should also be carried out before recommissioning following maintenance work. This also allows you to ensure that all earthing cables were removed, for example.



 WARNING	Install the Overhead Line Measuring Set according to section 2.2.4. A low-resistance and solid connection of the choking coil to earth is of particular importance. Severe danger to life and limb as well as to the equipment may arise if you do not follow the procedure described in section 2.2.
---	---

For how to operate the Teleflex VX, please refer to its accompanying instruction manual.

2.3.7.1 PASSIVE MEASUREMENT

Step	Action
1	Connect the connecting box to mains; green lamp lights up (temperature monitoring of the choking coil is enabled).
2	Leave the key switch of the connection box in OFF position and make sure the "P / A" pushbutton is not pressed (this step is only necessary for models with internal pulse generator).
3	Switch on the Teleflex VX.
4	<p>Bring up the relevant "fingerprint" trace (see also section 2.3.6) from the history database of the Teleflex VX.</p> <hr/> <div style="border: 1px solid black; padding: 5px; display: inline-block;"> <p>i The history database should be called up directly from the main menu even before the operating mode has been selected. In this way you can ensure that the Teleflex VX automatically starts in the operating mode appropriate for the loaded measurement and the measurement parameters are set to the values used in the recording of the "fingerprint".</p> </div> <hr/>
5	Select the „L1-N“ option from the phase selection menu of the Teleflex VX.
6	<p>Start recording a current reflectogram for comparative purposes using menu item .</p> <p>The Teleflex VX now performs 256 successive measurements and constantly updates the trace shown on the display. This trace represents the average value of the traces recorded up to that point.</p> <p>The measurement then stops automatically.</p>
7	Compare the two displayed traces with each other and try to find the causes for any deviations.

2.3.7.2 ACTIVE MEASUREMENT (INTERNAL PULSE GENERATOR REQUIRED)

Step	Action
1	Set "Trigger" switch (11) to "off" position
2	Connect the connecting box to mains; green lamp lights up (temperature monitoring of the choking coil is enabled)
3	Switch the key switch in „ON“ position and press the "P / A" pushbutton. The red "P / A" pushbutton lights up.
4	Select the trigger mode using the „Trigger“ switch (11) intern. pulses are automatically released by the internal generator at a rate of 2 Hz (red LED flashes with any pulse) manual the red „Manual“ pushbutton (12) is lit; a pulse can be triggered by pressing the pushbutton (≤ 2 Hz) (red LED flashes with any pulse) extern. apply trigger signal to BNC socket (13); with each L/H slope of the trigger signal (repetition rate ≤ 2 Hz) a test pulse is generated and the red LED flashes
5	Switch on the Teleflex VX.
6	Bring up the relevant "fingerprint" trace (see also section 2.3.6) from the history database of the Teleflex VX. <div style="border: 1px solid black; padding: 5px; margin: 10px 0;">  The history database should be called up directly from the main menu even before the operating mode has been selected. In this way you can ensure that the Teleflex VX automatically starts in the operating mode appropriate for the loaded measurement and the measurement parameters are set to the values used in the recording of the "fingerprint". </div>
7	Select the „L1-N“ option from the phase selection menu of the Teleflex VX.
8	The measurement parameters set on the pulse generator during the recording of the loaded "fingerprint" can be displayed using menu item  . Set the pulse generator to precisely these values.
9	Start recording a current reflectogram for comparative purposes using menu item  .
10	Depending on the selected trigger mode, trigger the pulse generator to release a pulse

11	<p>The Teleflex VX now records 256 successive reflectograms in time with the triggerings made and constantly updates the trace shown on the display. This trace represents the average value of the traces recorded up to that point.</p> <p>The trace is then frozen and further triggerings by the pulse generator are ignored.</p>
12	<p>Compare the two displayed traces with each other and try to find the causes for any deviations.</p>

Chapter 3

CARE AND MAINTENANCE

3 CARE AND MAINTENANCE

If any component part of your Overhead line measuring set has got defective, please submit it to your service shop or to Megger for repair.

The fuses in the mains socket of the pulse generator are rated at 0.315A, slow-acting.

For replacing a lamp in one of the switches, keys or lamp holder of the pulse generator, please proceed as follows:

- Loosen the sleeve nut of the switch
- Push the switch through the front panel until the coloured cap can be removed
- Replace lamp using the lamp pulling tool (see spare part kit)

Make sure that the choke circuit is tested annually for being low-resistive ($\leq 0.5 \Omega$).

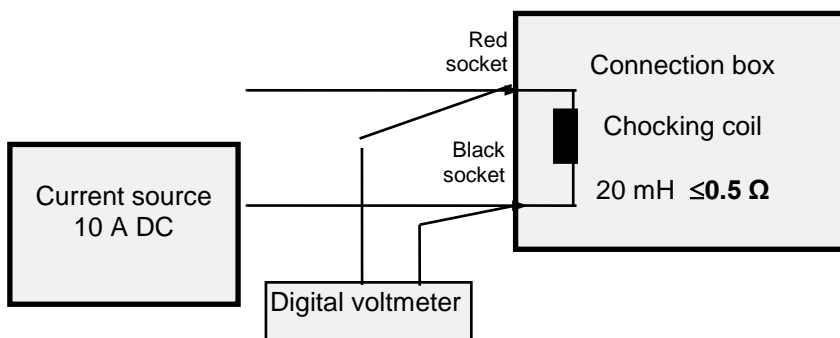

Fig 6 Test Stand of Choke Circuit

Use a current source to feed a current of 10A DC into the pulse generator through the red and black sockets. Thus the current will flow through the choking coil. Use a digital voltmeter to measure the potential difference between the red and black sockets. The potential difference is required to be equal to or less than 5 V.

ANNEX

Appendix 1

Differential Measurement

When a differential test is performed, the test pulse is transmitted to two phases. This means that with this system you need two overhead line measuring sets switched to passive mode if you wish to perform a differential test.

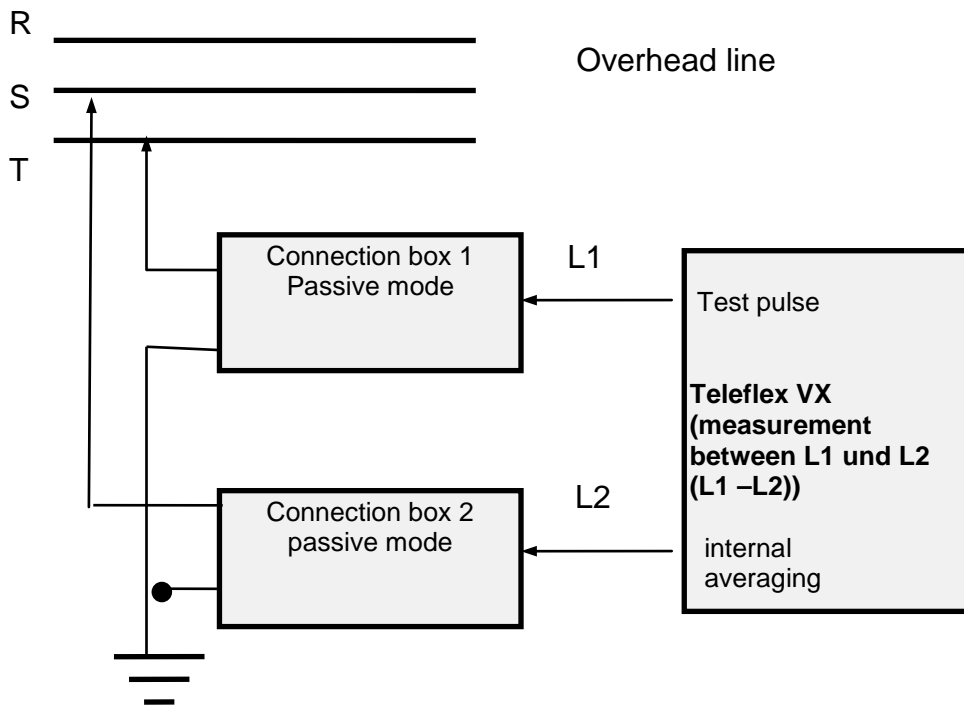

Fig 7 Principle of Differential Testing

Any reflections with identical polarities, identical waveform, identical amplitude and identical travel time will not be indicated. Only differences will be shown. For locating faults this means that no evaluation is possible if both conductors have the same fault in the same place. For this reason you should always perform a comparative test of the three phases before making a differential measurement. After that it is easier to decide between which phases the differential test shall be performed.

In some cases faults are easier to detect by means of the differential method. On the other hand, differential testing of overhead lines may be more difficult than on cables, as possible irregularities (small deviations of Z along the three conductors) often differ in their distribution along the line.

Differential testing may be very helpful in cases where short cable sections alternate with the overhead line. The junctions "overhead line – cable – overhead line" cause relatively strong reflections which are considerably reduced by this method. Once again this will only work on condition that there must not be any identical fault in the same place of either conductor under test.

Differential testing eliminates part of the HF interference. However, this does not apply to HF telephony as the signals on all three phases are not identical.

Appendix 2

Dependence of the maximum range of measurement from pulse width:

Pulse width	Maximum range $v/2 = 80\text{m}/\mu\text{s}$	Maximum range $v/2 = 147.5\text{m}/\mu\text{s}$
50 ns	1.6 km	2.9 km
100 ns	3.2 km	5.9 km
200 ns	6.4 km	11.8 km
500 ns	16 km	23.5 km
1 μs	32 km	47.1 km
2 μs	64 km	94.4 km
5 μs	160 km	300 km



Tento symbol indikuje, že výrobek nesoucí takovéto označení nelze likvidovat společně s běžným domovním odpadem. Jelikož se jedná o produkt obchodovaný mezi podnikatelskými subjekty (B2B), nelze jej likvidovat ani ve veřejných sběrných dvorech. Pokud se potřebujete tohoto výrobku zbavit, obraťte se na organizaci specializující se na likvidaci starých elektrických spotřebičů v blízkosti svého působíště.



Dit symbool duidt aan dat het product met dit symbool niet verwijderd mag worden als gewoon huishoudelijk afval. Dit is een product voor industrieel gebruik, wat betekent dat het ook niet afgeleverd mag worden aan afvalcentra voor huishoudelijk afval. Als u dit product wilt verwijderen, gelieve dit op de juiste manier te doen en het naar een nabij gelegen organisatie te brengen gespecialiseerd in de verwijdering van oud elektrisch materiaal.



This symbol indicates that the product which is marked in this way should not be disposed of as normal household waste. As it is a B2B product, it may also not be disposed of at civic disposal centres. If you wish to dispose of this product, please do so properly by taking it to an organisation specialising in the disposal of old electrical equipment near you.



Този знак означава, че продуктът, обозначен по този начин, не трябва да се изхвърля като битов отпадък. Тъй като е B2B продукт, не бива да се изхвърля и в градски пунктове за отпадъци. Ако желаете да извърлите продукта, го занесете в пункт, специализиран в изхвърлянето на старо електрическо оборудване.



Dette symbol viser, at det produkt, der er markeret på denne måde, ikke må kasseres som almindeligt husholdningsaffald. Eftersom det er et B2B produkt, må det heller ikke bortskaffes på offentlige genbrugsstationer. Skal dette produkt kasseres, skal det gøres ordentligt ved at bringe det til en nærliggende organisation, der er specialiseret i at bortskaffe gammelt el-udstyr.



Selleli sümbooliga tähistatud toodet ei tohi käidelda tavalise olmejäätmena. Kuna tegemist on B2B-klassi kuuluva tootega, siis ei tohi seda viia kohaliku jäätmekäitluspunkti. Kui soovite selle toote ära visata, siis viige see lähimasse vanade elektriseadmete käitlemisele spetsialiseerunud ettevõttesse.



Tällä merkinnällä ilmoitetaan, että kyseisellä merkinnällä varustettua tuotetta ei saa hävittää tavallisen kotitalousjätteen seassa. Koska kyseessä on yritysten välisen kaupan tuote, sitä ei saa myöskään viedä kuluttajien käyttöön tarkoitettuihin keräyspisteisiin. Jos haluatte hävittää tämän tuotteen, ottakaa yhteys lähimpään vanhojen sähkölaitteiden hävittämiseen erikoistuneeseen organisaatioon.



Ce symbole indique que le produit sur lequel il figure ne peut pas être éliminé comme un déchet ménager ordinaire. Comme il s'agit d'un produit B2B, il ne peut pas non plus être déposé dans une déchetterie municipale. Pour éliminer ce produit, amenez-le à l'organisation spécialisée dans l'élimination d'anciens équipements électriques la plus proche de chez vous.



Cuireann an siombail seo in iúl nár cheart an táirgeadh atá marcáilte sa tsli seo a dhiúscairt sa chóras fuíoll teaghlaigh. Os rud é gur táirgeadh ghnó le gnó (B2B) é, ní féidir é a dhiúscairt ach oiread in ionaid dhiúscairtha phobail. Más mian leat an táirgeadh seo a dhiúscairt, déan é a thógáil ag eagraíocht gar duit a sainfheidhmiann i ndiúscairt sean-fhearas leictrigh.



Dieses Symbol zeigt an, dass das damit gekennzeichnete Produkt nicht als normaler Haushaltsabfall entsorgt werden soll. Da es sich um ein B2B-Gerät handelt, darf es auch nicht bei kommunalen Wertstoffhöfen abgegeben werden. Wenn Sie dieses Gerät entsorgen möchten, bringen Sie es bitte sachgemäß zu einem Entsorger für Elektroaltgeräte in Ihrer Nähe.



Αυτό το σύμβολο υποδεικνύει ότι το προϊόν που φέρει τη σήμανση αυτή δεν πρέπει να απορριπτεται μαζί με τα οικιακά απορρίματα. Καθώς πρόκειται για προϊόν B2B, δεν πρέπει να απορριπτεται σε δημοτικά σημεία απόρριψης. Εάν θέλετε να απορριψετε το προϊόν αυτό, παρακαλούμε όπως να το παραδώσετε σε μία υπηρεσία συλλογής ηλεκτρικού εξοπλισμού της περιοχής σας.



Ez a jelzés azt jelenti, hogy az ilyen jelzéssel ellátott terméket tilos a háztartási hulladékokkal együtt kidobni. Mivel ez vállalati felhasználású termék, tilos a lakosság számára fenntartott hulladékgyűjtőbe dobni. Ha a terméket ki szeretné dobni, akkor vigye azt el a lakóhelyéhez közel működő, elhasznált elektromos berendezések begyűjtésével foglalkozó hulladékkezelő központhoz.



Questo simbolo indica che il prodotto non deve essere smaltito come un normale rifiuto domestico. In quanto prodotto B2B, può anche non essere smaltito in centri di smaltimento cittadino. Se si desidera smaltire il prodotto, consegnarlo a un organismo specializzato in smaltimento di apparecchiature elettriche vecchie.



Ští žíme noráda, ka izstrádajumu, uz kura tā atrodas, nedrīkst izmest kopā ar parastiem mājsaimniecības atkritumiem. Tā kā tas ir izstrādājums, ko cits citam pārdod un lieto tikai uzņēmumi, tad to nedrīkst arī izmest atkritumos tādās izgāztuvēs un atkritumu savāktuvēs, kas paredzētas vietējiem iedzīvotājiem. Ja būs vajadzīgs šo izstrādājumu izmest atkritumos, tad rīkojieties pēc noteikumiem un nogādājiet to tuvākajā vietā, kur īpaši nodarbojas ar vecu elektrisku ierīču savākšanu.



Šis simbols rodo, kad juo paženklinto gaminio negalima išmesti kaip paprastų buitinių atliekų. Kadangi tai B2B (verslas verslui) produktas, jo negalima atiduoti ir buitinių atliekų tvarkymo įmonėms. Jei norite išmesti šį gaminį, atlikite tai tinkamai, atiduodami jį arti jūsų esančiai specializuotai senos elektrinės įrangos utilizavimo organizacijai.



Dan is-simbolu jindika li l-prodott li huwa mmarkat b'dan il-mod m'ghandux jintrema b'hal skart normali tad-djar. Minhabba li huwa prodott B2B , ma jistax jintrema wkoll f'centri civici ghar-rimi ta' l-iskart. Jekk tkun tixtieq tarmi dan il-prodott, jekk joghgbok ghamel dan kif suppost billi tiehdu ghand organizzazzjoni fil-qrib li tispeccjalizza fir-rimi ta' taghmir qadim ta' l-eletriku.



Dette symbolet indikerer at produktet som er merket på denne måten ikke skal kastes som vanlig husholdningsavfall. Siden dette er et bedriftsprodukt, kan det heller ikke kastes ved en vanlig miljøstasjon. Hvis du ønsker å kaste dette produktet, er den riktige måten å gi det til en organisasjon i nærheten som spesialiserer seg på kassering av gammelt elektrisk utstyr.



Ten symbol oznacza, że produktu nim opatrzonemu nie należy usuwać z typowymi odpadami z gospodarstwa domowego. Jest to produkt typu B2B, nie należy go więc przekazywać na komunalne składowiska odpadów. Aby we właściwy sposób usunąć ten produkt, należy przekazać go do najbliższej placówki specjalizującej się w usuwaniu starych urządzeń elektrycznych.



Este símbolo indica que o produto com esta marcação não deve ser deixado fora juntamente com o lixo doméstico normal. Como se trata de um produto B2B, também não pode ser deixado fora em centros cívicos de recolha de lixo. Se quiser desfazer-se deste produto, faça-o correctamente entregando-o a uma organização especializada na eliminação de equipamento eléctrico antigo, próxima de si.



Acest simbol indică faptul că produsul marcat în acest fel nu trebuie aruncat ca și un gunoi menajer obișnuit. Deoarece acesta este un produs B2B, el nu trebuie aruncat nici la centrele de colectare urbane. Dacă vreți să aruncați acest produs, vă rugăm să-o faceți într-un mod adecvat, ducând-l la cea mai apropiată firmă specializată în colectarea echipamentelor electrice uzate.



Tento symbol znamená, že takto označený výrobek sa nesmie likvidovať ako bežný komunálny odpad. Keďže sa jedná o výrobok triedy B2B, nesmie sa likvidovať ani na mestských skládkach odpadu. Ak chcete tento výrobok likvidovať, odneste ho do najbližšej organizácie, ktorá sa špecializuje na likvidáciu starých elektrických zariadení.



Ta simbol pomeni, da izdelka, ki je z njim označen, ne smete zavreči kot običajne gospodinjne odpadke. Ker je to izdelek, namenjen za druge proizvajalce, ga ni dovoljeno odlagati v centrih za civilno odlaganje odpadkov. Če želite izdelek zavreči, prosimo, da to storite v skladu s predpisi, tako da ga odpeljete v bližnjo organizacijo, ki je specializirana za odlaganje stare električne opreme.



Este símbolo indica que el producto así señalizado no debe desecharse como los residuos domésticos normales. Dado que es un producto de consumo profesional, tampoco debe llevarse a centros de recogida selectiva municipales. Si desea desechar este producto, hágalo debidamente acudiendo a una organización de su zona que esté especializada en el tratamiento de residuos de aparatos eléctricos usados.



Den här symbolen indikerar att produkten inte får blandas med normalt hushållsavfall då den är förbrukad. Eftersom produkten är en så kallad B2B-produkt är den inte avsedd för privata konsumenter, den får således inte avfallshanteras på allmänna miljö- eller återvinningsstationer då den är förbrukad. Om ni vill avfallshandla den här produkten på rätt sätt, ska ni lämna den till myndighet eller företag, specialiserad på avfallshantering av förbrukad elektrisk utrustning i ert närområde.