

INTEGRATED SOLUTIONS FROM POWER DIAGNOSTIX BY MEGGER



Power Diagnostix is a provider of instruments designed to detect partial discharge (PD) in electrical insulation before the system is compromised.

FOR FACTORY AND LABORATORY PARTIAL DISCHARGE TESTING

Not only does Power Diagnostix have a large portfolio for such instruments, but it also assists in providing corresponding interpretation and diagnostics of insulation conditions and offers expert technical services.



Power Diagnostix



In 1986, Power Diagnostix was founded in Aachen, Germany to provide solutions for identifying potential defects in insulation systems before a failure occurs. It sought to achieve this primarily by offering partial discharge measuring instruments, as well as with tan delta and high voltage testing equipment.

In June 2019, Power Diagnostix joined the Megger group. Although Megger has had one of the largest product portfolios in the electrical testing industry for over a century, it identified Power Diagnostix as the perfect addition to the Megger team and brought it on board.

PD is a precursor to serious insulation degradation which can lead to failures of electrical components. PD can be caused by imperfections in the insulation system as well as by external factors. Once partial discharge has occurred, it steadily increases over time as the insulation continues to degrade, ultimately leading to irreversible damage and failure. Therefore, it is necessary to detect PD as soon as possible, which can be done using various measurement techniques, such as measuring charge in various frequency ranges or by acoustic detection.

One of the most cherished philosophies of Power Diagnostix by Megger is to be customer-oriented and tackle the issue of PD measurement by working closely with its customers to learn about their challenges and needs.



One of the most cherished philosophies of Power Diagnostix by Megger is to be customer-oriented and as such, it tackles the issue of PD measurement by working closely with its customers to learn about their challenges and needs. In this way, Power Diagnostix serves, as a partner, to implement solutions, closely cooperating with its customers through consulting, commissioning, and after-sales support. This enables engineers to stay up-to-date on current trends and industry requests to drive the development and improvement of products and services.

Power Diagnostix serves, as a partner, to implement solutions, closely cooperating with its customers through consulting, commissioning, and after-sales support.

From portable testing instruments for field use, to permanently installed monitoring systems for a variety of electrical applications, all solutions are configured specifically based on the customer's needs. This is especially the case when it comes to solutions for high voltage testing laboratories, as each project is custom designed **with** the customer. These solutions are often supplied for use in production line testing, factory acceptance testing (FAT), or quality control after repairs. Given this range of solutions for power transformers and other electrical applications, it is not surprising that Power Diagnostix caters to a wide variety of customer industries, including Original Equipment Manufacturers (OEMs), testing and calibration laboratories, repair shops, and research and education institutions.

Modular concept for laboratory and factory testing applications

Increased testing demands from customers drive the need for time saving, automation, and improved performance and functionality. Modular solutions from Power Diagnostix allow testing laboratories to extend their testing capacity, enhance their technical capabilities, and modernise their equipment to meet customer's needs and to maintain efficiency.

Generally, laboratory applications consist of several main components: partial discharge measuring instrument and associated accessories, high voltage power supply, high voltage control unit, software for control, measurement and reporting, and, most importantly, safety provisions. For each project, components are configured specifically based on voltage level, objects being tested, test procedure, number of measurement channels, noise conditions, desired level of automation, and more.

As an example, a typical testing configuration for PD quality assurance and quality control in the manufacturing of products such as bushings or voltage transformers includes:

- Single PD measurement channel
- Coupling capacitor, quadrupole, and pre-amplifier
- Noise gating
- Optional 4 or 12 channel multiplexer for testing multiple samples
- PD spectrum analysis option

For production line or factory acceptance testing of samples such as bushings or voltage transformers, the ICMcompact is typically the preferred instrument for partial discharge testing. This instrument allows testing according to IEC 60270, easy setup, and can adapt to specific test applications and interference situations through various accessories. Additionally, ICMcompact can be integrated into an automated test bench with other test equipment and automation software as described further in this article.

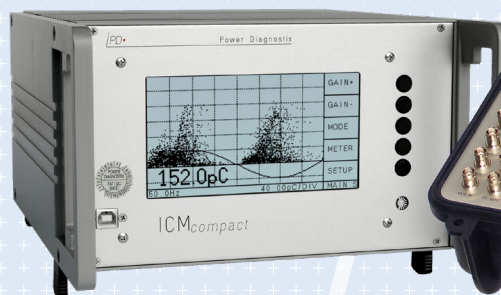

The ICMcompact shown in two of three available housing versions

A typical configuration for power transformer factory acceptance testing of partial discharge includes:

- 6 to 10 parallel PD measurement channels
- Coupling capacitors, quadrupoles, and pre-amplifiers
- Noise gating
- Phase Resolved Partial Discharge (PRPD) analysis software
- Acceptance test reporting software

Most commonly, when testing three-phase power transformers, an instrument with multiple measurement channels is used. This allows for testing all three phases of the primary and secondary windings simultaneously (6 or 8 channels with neutral bushings). Measuring PD in parallel on all bushings saves the user time with lead connections, accessory configuration and calibration, and total measurement duration. Additional channels can be used for acoustic or Ultra High Frequency (UHF) PD sensors or noise gating (filtering) via a high frequency current transformer or noise antenna, which ensures accurate and sensitive measurements. This saves time and effort and allows better comparison of PD results between phases.

Power Diagnostix is more than a manufacturer of partial discharge testing instruments. We are also involved with the development, design, configuration, and integration of the full system, and provide customer training and commissioning.

For three-phase power transformer factory acceptance testing, a multi-channel ICMsystem is preferably used due to enhanced tools for in-depth analysis. With its true parallel PD acquisition of up to ten channels, the overall testing period is substantially shortened by features such as the automatic calibration cross-coupling matrix. ICMsystem offers both - narrow and wide band PD pattern acquisition, according to IEC 60270. The instrument comes with an embedded spectrum analyser for advanced PD analysis in frequency domain. Moreover, it is an excellent tool to use in case of noisy test environments. Additionally, acoustic sensors can be interfaced with ICMsystem for PD fault localisation.



ICMsystem desktop version

Automation for laboratory and factory acceptance testing

Different levels of automation can be provided depending on the test. In the case of full production testing, a high level of automation and a simple go/no-go decision is required. This enables testing technicians to be trained for standardised working procedures during or after production so that in-depth PD knowledge or detailed result analysis is not necessary for daily work.



Alternatively, manual control offers a higher level of flexibility when testing samples or sample variants during development. Automated laboratory solutions typically start with a configuration of ICMcompact (PD measuring device), HVcontrol (High voltage test control unit), a testing transformer, and noise filtering hardware. These components are fully integrated with the HVpilot software so that users can benefit from one automated interface for voltage control including automated ramp sequences, PD measurements, and test reporting. Additionally, TDAcompact is optionally integrated for tan delta testing.

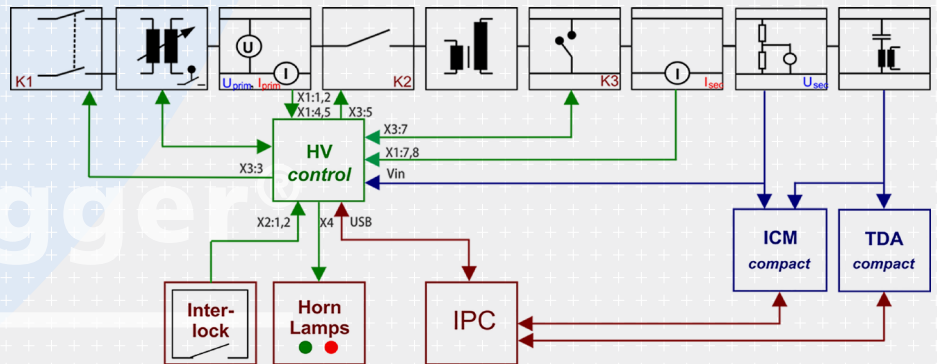

Example functional diagram of an integrated test lab setup from Power Diagnostix by Megger

The system is always integrated with a safety interlock with HVcontrol, horns and/or lamps, as well as manual and automatic earthing discharge rods. These provisions are mandatory in order to prevent exposure of testing personnel to hazardous voltages.

Most customers for this type of application prefer the 19" rack-mountable version for the measuring and control instruments that are integrated permanently into the test bench. This provides convenience for laboratory testing, especially where test routines and samples are repetitive. Cables, instruments, sensors, and other accessories can be fixed installed to prevent loss or damage and to save time with connections and configurations. Optionally, a dedicated built-in computer results in less time spent configuring software or troubleshooting IT issues. An additional advantage for test bench integration is that test sequences and results are stored in one central location.

Users who require portability and field use can be provided with test instruments in rugged portable or desktop enclosures as a suitable alternative.



ICMcompact embedded in a control desk with additional control hardware

Additional integration options

High voltage test chambers (HVTC) can be added to the configuration to provide isolation from noisy conditions and are suitable for PD testing according to international standards. These solutions also allow owners to save space for their testing setup in comparison to an open area where distance, fencing, and isolation are required for safety purposes during high voltage testing.

Tan delta (dissipation factor) measurement is an additional method used to assess the condition of an insulation system for transformers and other electrical equipment. The TDACompact from Power Diagnostix can be also integrated into such laboratory setups for this purpose. This results in additional convenience and saves time as users can conduct pre-programmed test sequences for voltage step, PD, and tan delta all simultaneously with integrated software from one interface.

Due to the modular approach, customers have the ability to choose many parameters to fulfill their current testing needs. This provides flexibility with voltage levels, type of test instruments, level of automation, and optional hardware and software features. Also, upgrading and retrofitting in the future is possible as needs change.

Supplementing laboratory capabilities with mobile support

Power Diagnostix isn't just a manufacturer of partial discharge testing instruments. Engineers are also involved with the development, design, configuration, and integration of the full system. Additionally, Power Diagnostix provides customer training and commissioning. After the system is installed and in service, the job does not stop there.



Power Diagnostix mobile test system

From portable testing instruments for field use, to permanently installed monitoring systems for a variety of electrical applications, all solutions are configured specifically based on the customer's needs.

Service Engineers are happy to offer consultation, result analysis, and measurement support. If a testing laboratory faces a job that exceeds their hardware or manpower capabilities, experts from the Service Department are available for on-site testing using mobile test laboratories.

Whether it's to support factory acceptance testing for unusual or challenging cases, site acceptance testing at the equipment owner's site, or PD localisation while the equipment is in operation, Power Diagnostix Service is the trusted partner for PD for your power transformers and other applications. We travel Europe-wide to your site with our mobile test systems. Besides PD, we are also happy to offer additional diagnostic tests for your applications, such as three-phase induced tests (up to 90 kV), applied voltage (up to 500 kV), tan delta/loss factor, ratio tests, winding tests, insulation tests, and more.