

## Transformer Health Management using Temporary On-Line Partial Discharge Monitoring

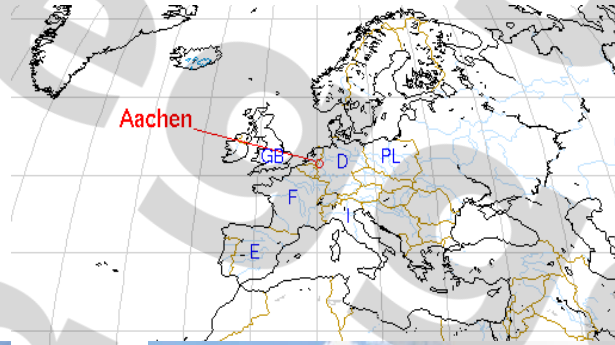

Dr. Mihai Huzmezan

Managing Director  
Power Diagnostix Systems GmbH  
Vaalser Strasse 250,  
52074 Aachen, Germany  
huzmezan@pdix.com



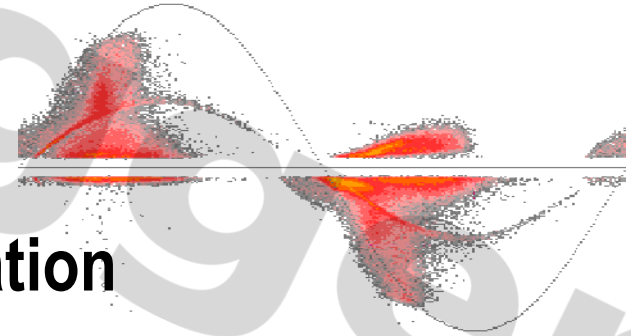

- **PDIX by Megger Group Presentation**
- Why PD monitoring of Power Transformers?
- System technical details
- Remote Connectivity and Software
- On-site testing of Power Transformers

## Megger Diagnostic Holding GmbH

**Power Diagnostix Systems GmbH**  
- Sales and Distribution

**Power Diagnostix Service GmbH**  
- Measurement Services, Mobile Test Systems

**Power Diagnostix Instruments GmbH**  
- Development and Production

- Three Companies operated as a group
- Executive Board: Detlev Gross, Mihai Huzmezan, Markus Söller
- Running a very lean structure
- Employees having multiple roles within the Team
- ~50% of company staff are engineers
- German high level of in-house production & quality control
- We do everything in house:
  - Hardware (Analog & Digital) design, Software & Firmware Programming, Project Management, Technical Sales, Back office, Services, Repairs, Development, QM & Calibration, Production

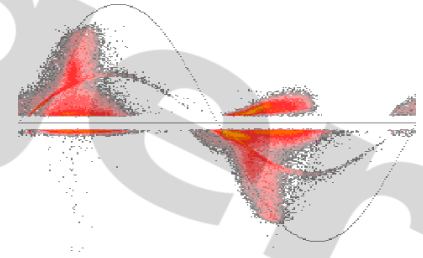

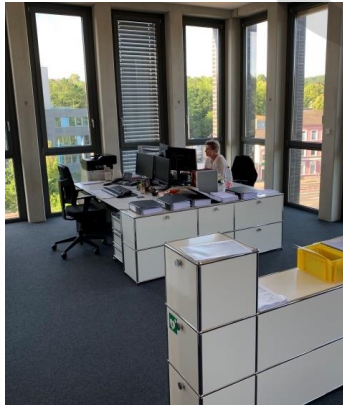

- Instruments for Partial Discharge and Loss Factor Measurement
- Control Systems for PD test benches
- PD Monitoring Systems
- DAkkS Calibration Laboratory
- Consulting, Service, Seminars, and Training



- Wide Range of Applications
- Measurement Tools for the whole Product Life-Cycle
- Applicable from below 1kV up to EHV (>1MV)
- Instruments made for tough Industrial Conditions



## Generators and Motors

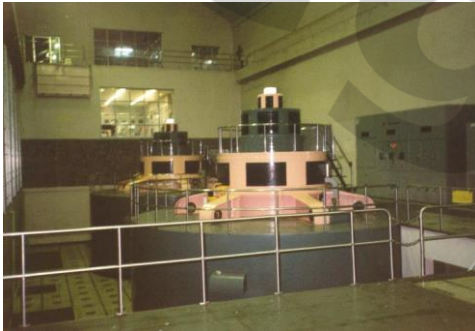

## GIS/GIL



- PD/TD Acceptance Testing in the Laboratory
- Testing under AC and DC Voltages
- Non Conventional Test methods for Onsite Testing
- Research on Insulation Materials

## Research

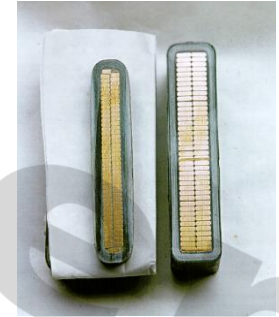

## Transformers, Bushings



## Power Cables, Joints, Terminations



## So called "Portable Products"

- ICMsystem
- ICMcompact
- AIACompact
- ICMflex
- ICMmonitor portable



## PD Monitoring systems

- ICMmonitor
- GISmonitor

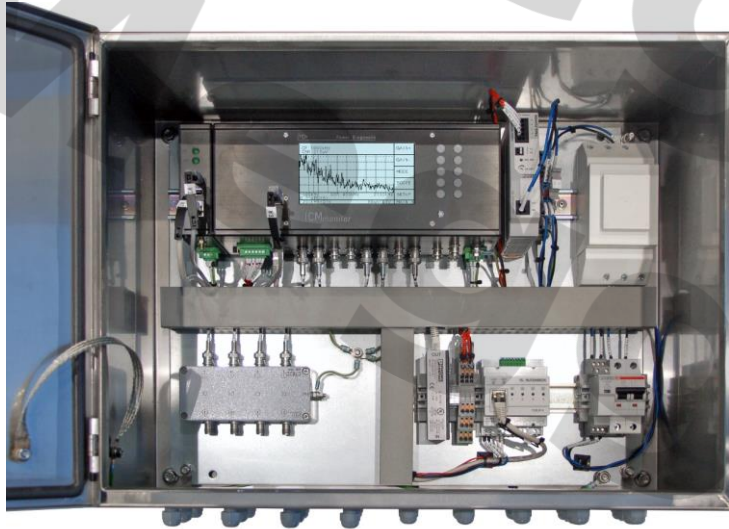

## Special devices and systems

- TDAcompact
- RIVmeter
- ATTalyzer
- HVcontrol, HVcompact, STEPcompact
- FOsystem (FOS1 – FOS4)



- DAkkS calibration services; 1<sup>st</sup> accreditation in 2003
- 2018 reaccreditation according new ISO17025:2018
- ISO9001:2015 (quality) since 2016
- ISO14001:2015 (environment) since 2017
- Approved and preferred supplier for ABB, Siemens, GE, Koncar (Siemens), Air Liquide, MR, others
- Successful prequalification of PDM Systems for GIS (*GISmonitor*) with large utilities such as: DEWA (UAE), National Grid (KSA), Kahramaa (QA), PGCIL (India)



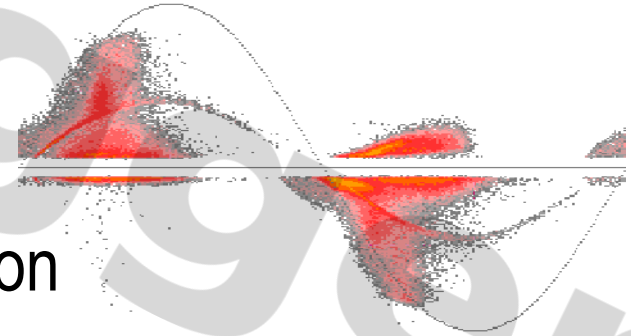

- PDIX by Megger Group Presentation
- **Why PD monitoring of Power Transformers?**
- System technical details
- Remote Connectivity and Software
- On-site testing of Power Transformers

Transformer Failure is costly and can be Disastrous...



- Increased population of aged substation equipment worldwide
  - In the past, no extended transformer maintenance programs
  - “No need for specific maintenance of static grid assets”
  - Delayed or cancelled investments by deregulations
  - Uncertainty on the condition of numerous transformers
- Possible consequences
  - Increased failure rate and risk
  - Unexpected outages long down times
  - Associated safety and environmental risks
  - Tremendous repair and transportation costs
- Transformer maintenance today
  - Different asset management approach
  - New maintenance strategies (predictive)
  - Cost & time saving solutions
  - Priority : condition assessment

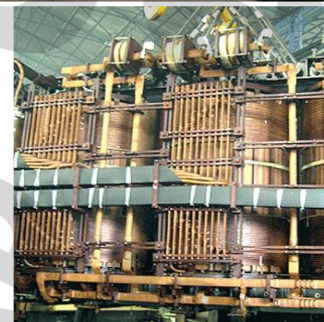

- High percentage of failures related to insulation problems
- Bushing and Winding problems can be detected by PD monitoring
- Early failures due to improper FAT, transportation, onsite commissioning
- Random failures caused by special stress (e.g. high load, lightning or switching impulses or ambient cond.)
- End of life failures due to aging of insulation materials

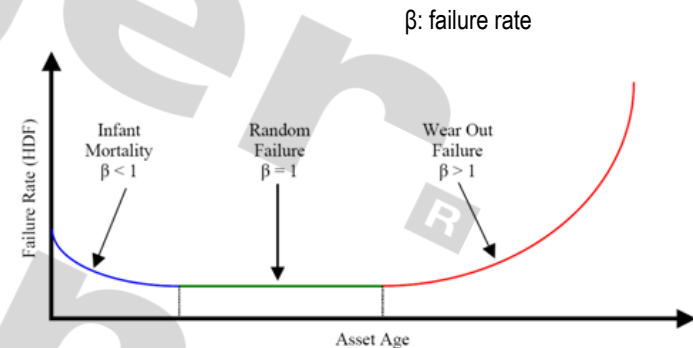
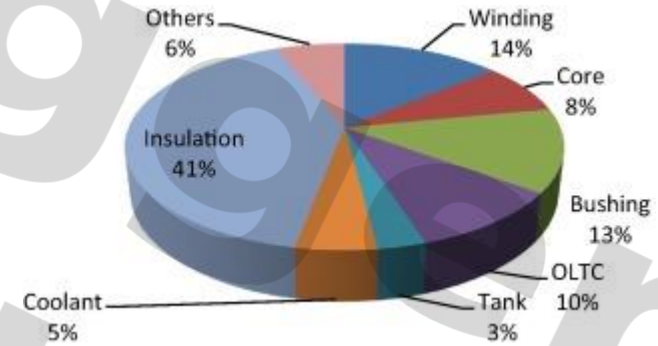

- **General Root Causes of PD in transformers**
  - Inferior quality of insulation materials
  - Fundamental design related problems
  - Incomplete or improper processing
  - Assembling related problems
  - Humidity in oil
- **Impact of Partial Discharges on transformer insulation systems**
  - Severity depends on the nature of the PD and location in the main tank
  - Accelerated degradation of Insulation materials
  - Reduced life expectancy of the grid system
  - Worst case scenario: unexpected breakdown → black outs



- Most common root causes:

- Inadequate vacuum stage prior to impregnation
- Insufficient drying of the active part before oil impregnation
- Remaining (conductive) particles in the oil
- Increased water content in the oil
  - reduced breakdown strength
- Missing electrical connections (e.g. floating static shields)
- Poor contacting of tap leads towards at OLTC
- Drops of casein glue in areas with elevated electrical fields

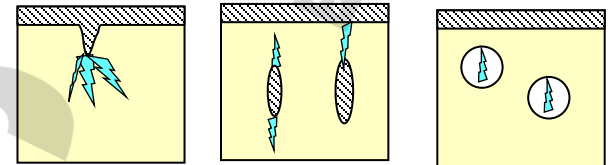
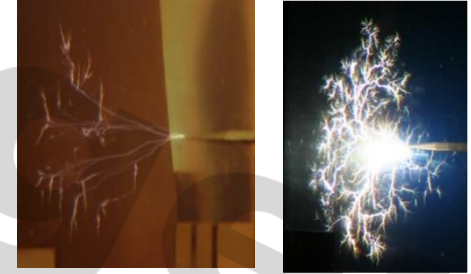

- PD Monitoring to assess insulation health of Power Transformers and Transformer Accessories
- PD Trending and Changing PD Patterns indicate incipient failure
- PD Pattern Analysis assists with failure Investigations (Root Cause Analysis)
- Added value if PD Monitoring is combined with DGA, Voltage, TD, Temperature and Load Monitoring



Foto: First PDM installation on a 400kV grid transformer (RWE) 1998

- Why/When ?

- Budget constraints
- After poor DGA-results
- No immediate long outage possible
- No fast availability of a mobile test system

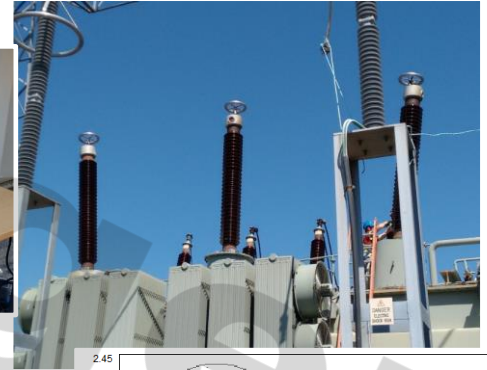
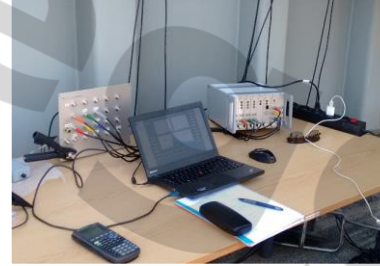

- How?

- Using permanently installed bushing adapters and BCU's
- Temporary installation of quadrupoles, HFCT's, UHF-antenna
- PD-test equipment
- Minor setup modifications → installation of corona rings

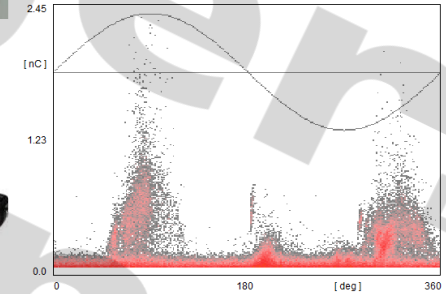

- Notes:

- Grid systems > 132 kV generally produces high repetitive external corona
- A more limited coverage compared to off-line testing → elevated detection bandwidths
- Acoustic PD-location attempts are generally more successful with an external power supply
- Data interpretation requires an operator with decent knowledge level

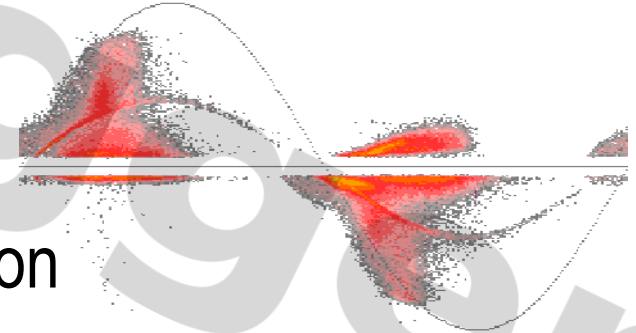

- PDIX by Megger Group Presentation
- Why PD monitoring of Power Transformers?
- **Technical details**
- Features and benefits
- On-site testing of Power Transformers

- Partial Discharge is a breakdown of a small area of the overall insulation
- Each PD pulse generates different measurable electrical signals:
  1. Local displacement current pulse
  2. Electromagnetic pulses
  3. Acoustic pulse

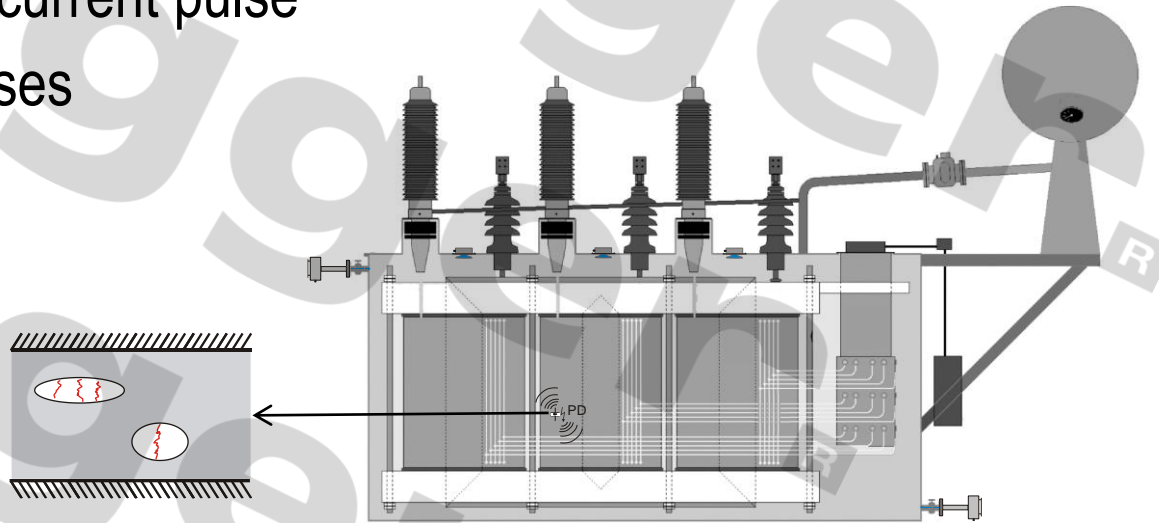

Electric PD Pulse taken from the test tap of a bushing

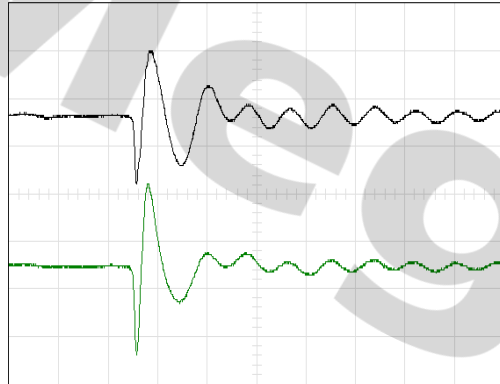

X Scale 10.00  $\mu$ s / DIV  
Y Scale CH1 1.00 V / DIV  
Y Scale CH2 1.00 V / DIV  
Y Position CH1 1.72 DIV  
Y Position CH2 -1.56 DIV

UHF PD Pulse taken from UHF antenna via oil valve

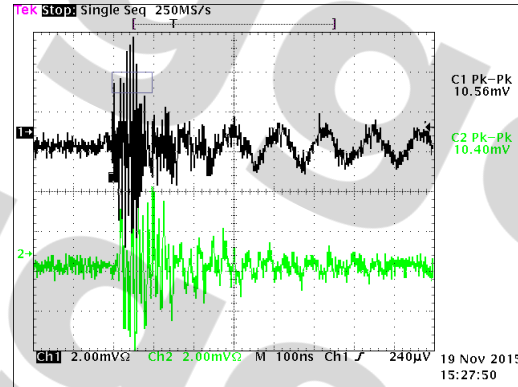

Acoustic Signal measured on the tank wall

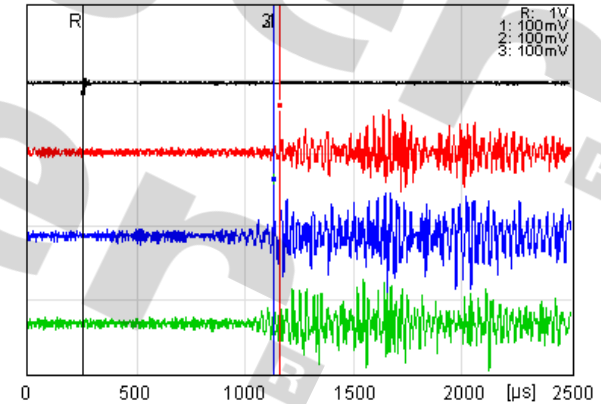

- PD and Sync from BCU to Input Multiplexer
- HF or UHF Sensors
- Noise Gating (DA1)
- Spectrum Scan
- PD Pattern & Trend
- OEM Solutions for Koncar and others...

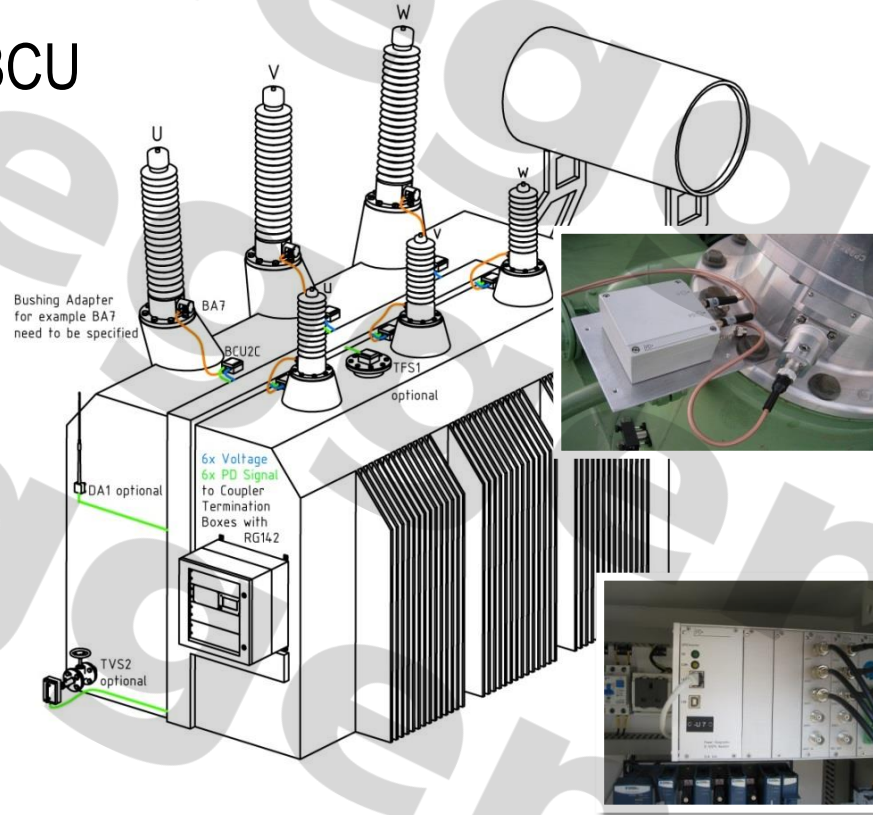

## Overview ICMmonitor

- Multiple Types and Designs
- Aluminum Enclosure
- Two 600Vdc Surge Arrestor
- Output Connector: N Type
- Protection Class: IP65
- Temp. Range: -40°...+90°C
- Stainless Steel Enclosures (available on request)

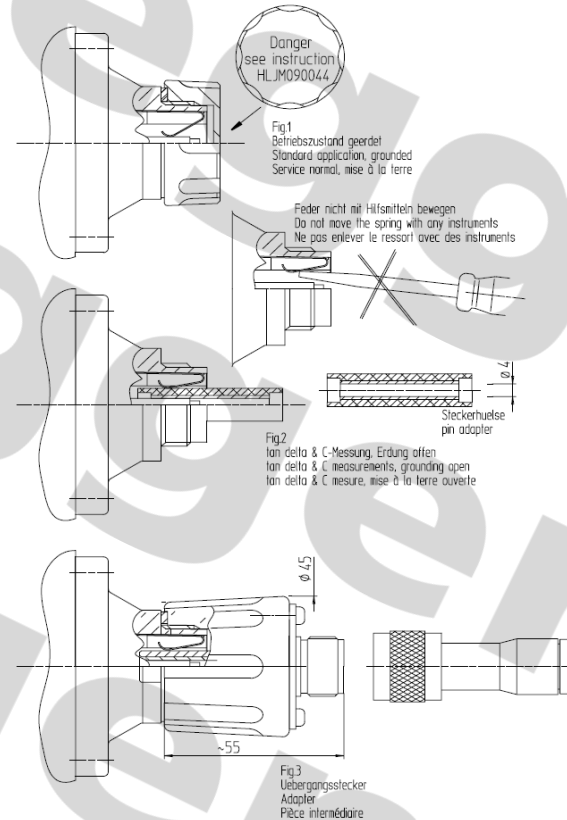

- PD Decoupling Circuit:  
HFCT or Quadrupole (switchable)
- Voltage Output via Capacitive Divider
- Two Output Connectors of N Type
- Protection Class: IP65
- Temperature Range: -40°C to 75°C
- Stainless Steel housing  
(available on request)



- Sensor for Noisy Site Conditions
- Transformer Valve Sensor (DN40 - DN50 and DN100 flanges)
- Hatch sensor (various diameters)
- Built-in logarithmic UHF signal converter
- Frequency Range: 300MHz – 1GHz
- TNC Output Connector
- Oil-tight Design

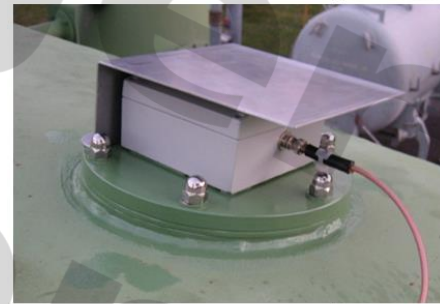

- Cables suited for extreme site temperatures and heavy weather conditions
- High Quality PTFE Teflon Coaxial Cable RG142, 50Ohm
- Recommended Distance (BCU to ICMmonitor) up to 20m
- CTB2C provides protective ground
- Both Cable Ends grounded and fitted with clamp-on ferrite cores

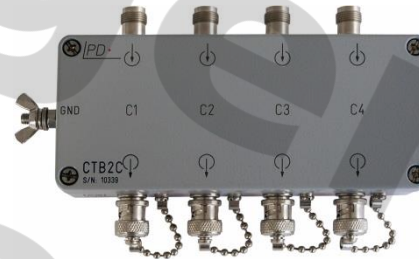

- Disturbance Antenna DA1 picks up Noise Pulses radiated by Corona for instance
- High Frequency Current Transformers CT1 or CT100 pick up Disturbance Pulses from shields of signal cables or from ground connections
- Instrument interrupts PD Measurement for the duration (in  $\mu\text{s}$ ) of Disturbance Pulses, (we call this Gating)



# Hardware - Acquisition Unit ICMmonitor

- 4, 8 or 12 Multiplexed PD Input Channels
- Separate Sync and Gating Inputs
- LAN and USB Interface
- 12-26Vdc Supply, 20VA max
- Customized Design for Hat-Rail Mounting
- Opt. 240x128px LC Display for Onsite Configuration and Inspection
- Commissioning and Monitoring Mode Frequency Selective Measurement
- Wide Band and Narrow Band Filter
- Spectrum Analysis
- UHF Measurement
- Dry Alarm Contacts
- IEC61850 (HW or SW)

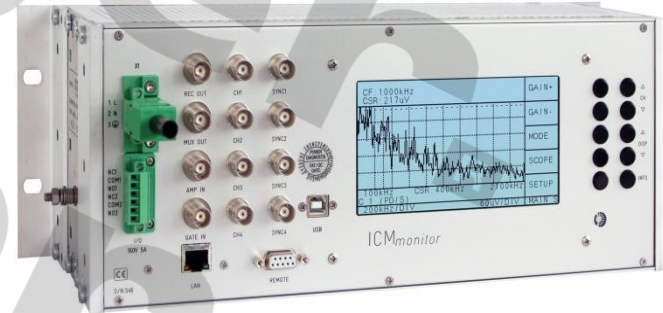
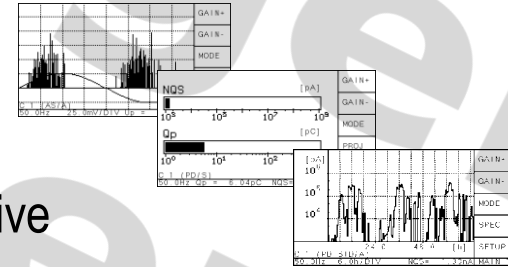

- Stainless steel cabinet
- ICMmonitor, CTB, Network Interface, IOs, Main Switch,...built-in
- Compact design(s)

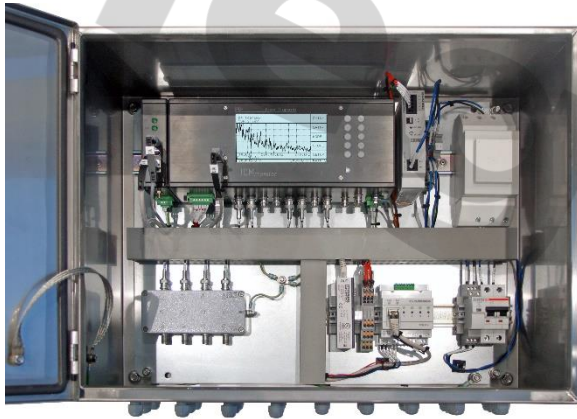

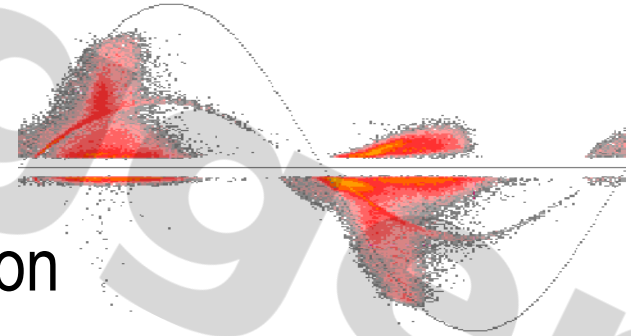

- PDIX by Megger Group Presentation
- Why PD monitoring of Power Transformers?
- System technical details
- **Remote Connectivity and Software**
- On-site testing of Power Transformers



- OS independent
- Direct Access via local IP address
- Full Description of API
- Access to specified Data Sets provided by the instrument
- Remote connectivity for Maintenance / Assessment during temporary testing

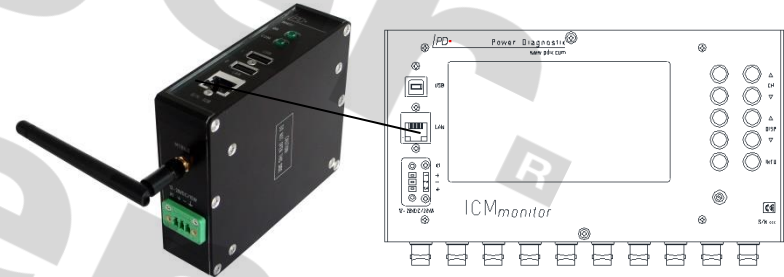
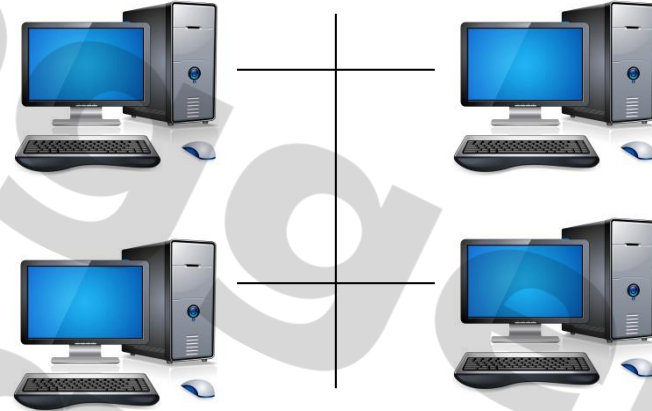

- Additional Hardware based **Device Communication Gateway**
- OS independent
- Provision of ICDs
- Full Description of all Data Sets and 61850 relevant documents
- Provided Data Sets such as:  
Current Readings of NQS, Qp,  
Alarm Status per Channel

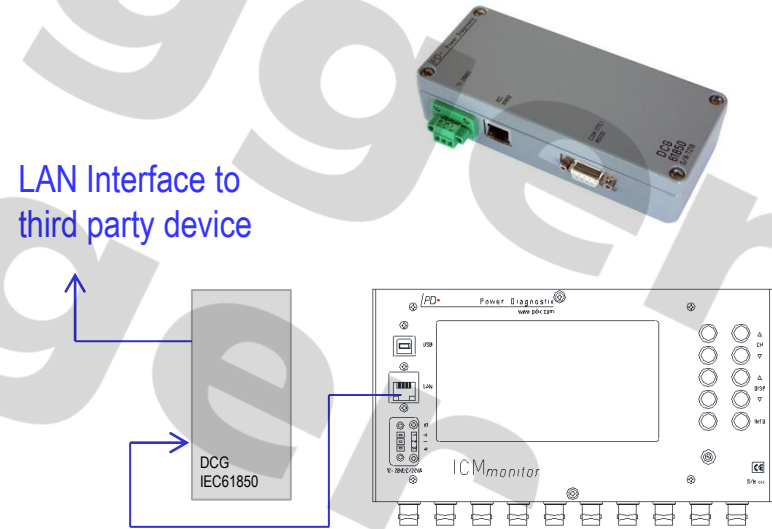

## Windows SW: ICMmonitor

- Remote Access to Multiple Monitoring Instruments
- Long Term Trending, History Structure
- Alarm Handling
- Colored PD Pattern Acquisition
- Automated Data Acquisition
- Connects via USB or LAN



## Advanced Data Management

- Database-Supported Handling of all Measurement Files and Supplementary Information
- PD Pattern Comparison
- PD Pattern Classification
- Storage of Photos, Comments, and all Instrument Settings with each Data Set
- Add On Tool for all Products

The screenshot displays the ICMexpert software interface, which is divided into several functional areas:

- Top Panel:** Shows two waveform plots. The left plot, titled 'BAR\_SURF.DAT', shows a signal with a peak of +21.3 and a trough of -21.3. The right plot, titled 'BAR\_GE2.DAT', shows a signal with a peak of +26.7 and a trough of -26.7. Both plots have a time axis from 0 to 360 degrees.
- Left Panel (Pattern Details):** Contains fields for Test Object Id (Transformer Bushing), Name of Test Object (TR596778), Report No. (R44920), Name of Report (Fault Analysis), Testing Person (Soeller), Inspector (Hering), Executive (Power Diagnostix), and a Comment (PD Failure of Fault Bushing detected at 1.3um PD Level about 2-3nC).
- Right Panel (Database Details):** Lists various parameters such as Pattern Identifier (test\_ch1\_3.dat), Location (Transformer TestLab), Power Supply (MG Set), Calibration Range (1nC), PD Insulation Sys (Epoxy), Condition (TestRoom), History (New Transformer), Action (Replacement of the bushing), and Known Faults (No).
- Bottom Panel (IMAGES):** Features a photograph of a transformer bushing with a finger pointing to a specific area. The description below reads: 'Surface Discharge due to damaged Epoxy Insulation'.
- Bottom Right Panel (Database):** Shows a table of database entries with columns for 'Void', 'Database Structure', 'Match', and 'nr'. The table lists various data files like BAR\_GE2.DAT, DEFAULT.DAT, EPJPOINT.DAT, PEJPOINT.DAT, PHASE1\_3.DAT, SM1706.DAT, SURF\_UN.DAT, SURF\_LOG.DAT, VOID.DAT, and WEISS.DAT. The 'Match' column shows a value of 53.02% for BAR\_GE2.DAT.

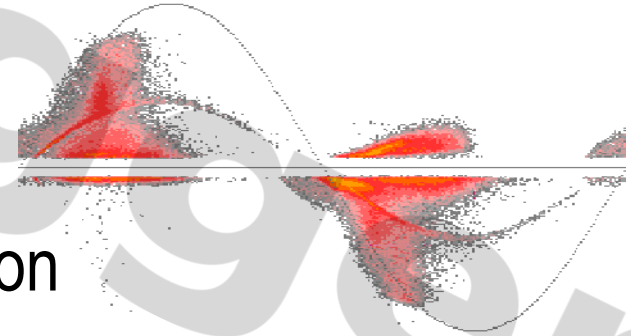

- PDIX by Megger Group Presentation
- Why PD monitoring of Power Transformers?
- System technical details
- Remote Connectivity and Software
- **On-site testing of Power Transformers**

# On-site testing of Power Transformers

- Once problems are spotted we can “move the factory testing to site”
  - Reducing down times
  - Active part repairs or coil exchanges
  - Power rating upgrades
  - Oil treatments and re-generation
- Increasing demand for on-site high voltage testing incl. PD-measurements
  - After site repairs and component replacements
  - In the commissioning stage
  - Verification of dissolved gas analysis (DGA) results
  - Confirmation of Bucholz or PD-monitor alarm events
- Requirement for compact mobile test systems
  - Light weighted test gear
  - Compact electronic power supply (converter-based)
  - Advanced multi-channel PD-detection system and accessories



ICMmonitor (PDIX) with ABB TEC system

# 1,3 MVA AC Mobile Test System



- 40 ft. High cube container ~ 38 tons
- Action radius : Europe ~ 1500km around Aachen
- Main application : Testing of Power Transformers (80% of the mobilizations)
- Others : Power cable (66kV - 155kV – 220kV) after installation testing

# 1,3 MVA AC Mobile Test System

- 1,3 MVA -Three phases induced voltage source
- 3 x 450 kVA inverter sets (15-200Hz)
- 2 MVA step-up or matching transformer
- 500 kV series resonant reactor (4A-15min)
- Embedded L/C compensation
- Advanced HF-noise filtering
- 400V power intake (diesel-generator)
- Control room with embedded advanced PDIX test equipment
  - Electrical and acoustic PD-measurements (multi-channel)
  - Norma 5000 power analyzer

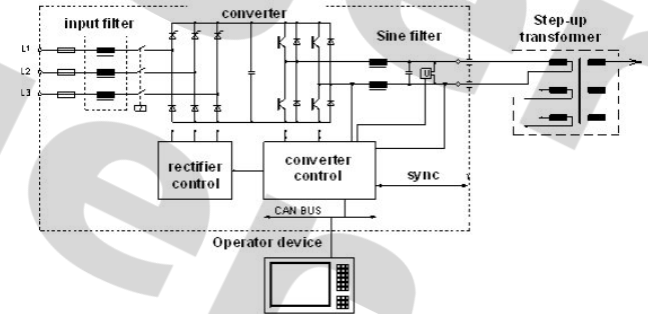
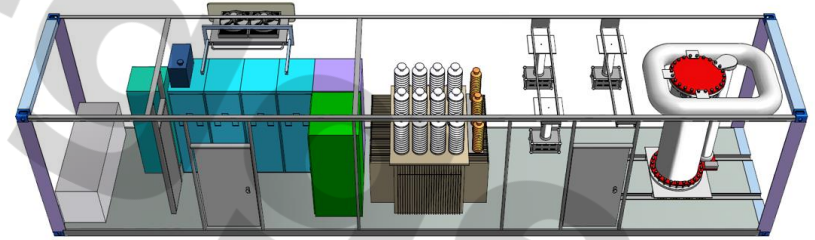

# 1,3 MVA AC Mobile Test System

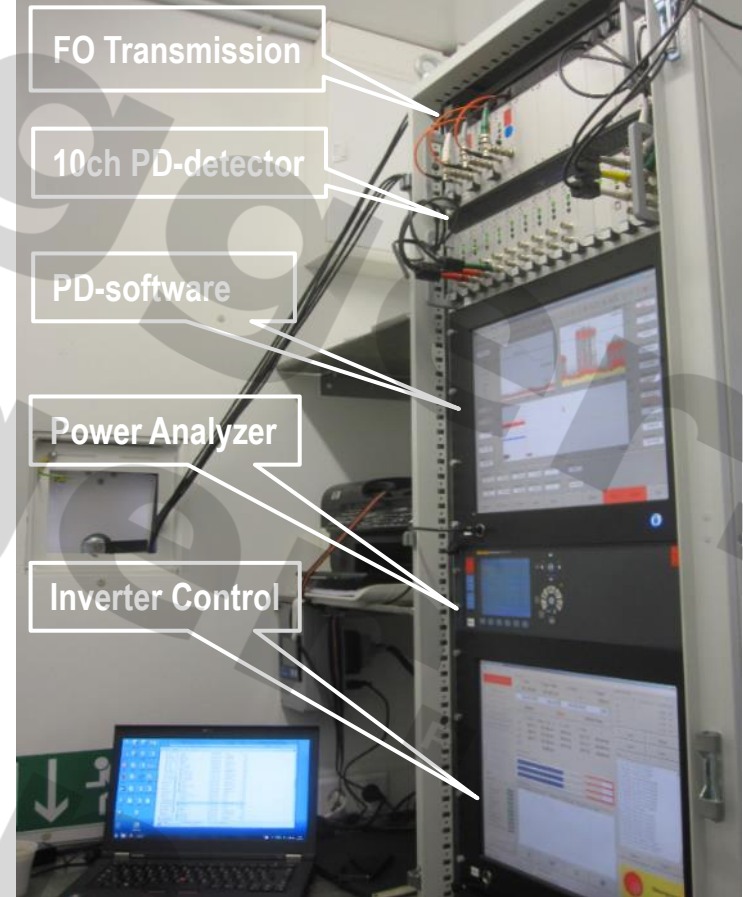

FO Transmission

10ch PD-detector

PD-software

Power Analyzer

Inverter Control

- Site acceptance testing (SAT) and diagnostic testing under induced and applied voltage
- Separate source AC-withstand tests up to 500kV with series resonant reactor (4A max – 15min)
- Three phases induced voltage tests up to 90kV (ph-ph) acc. to IEC 600076-3 (up to 1,3 MVA)
- Single phase induced voltage testing up to 70 kV– (up to 1,3 MVA)
- Single phase induced voltage testing up to 104 kV with symmetrical excitation – (up to 900 kVA)
- No load loss measurements (~ 500kW)
- Load losses or impedance voltage tests (achievable level to be calculated in advance)
- Electrical PD-measurements and Acoustic PD-location

# Installing “the shielded test room” onsite

- Shielded MV-power cables
- Corona shields
- PD-free connections
- Gating sensors
- HF-Line Filters
- Advanced spectrum analysis

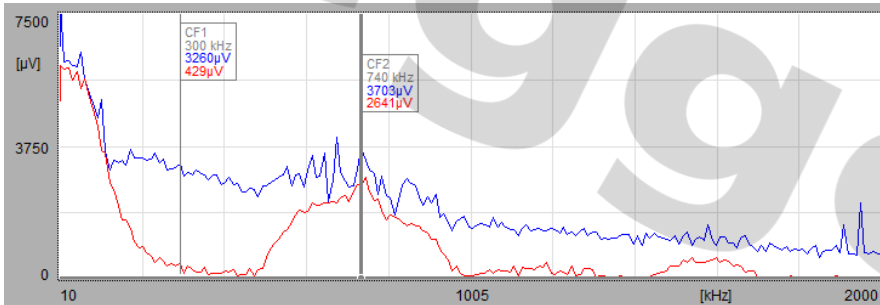
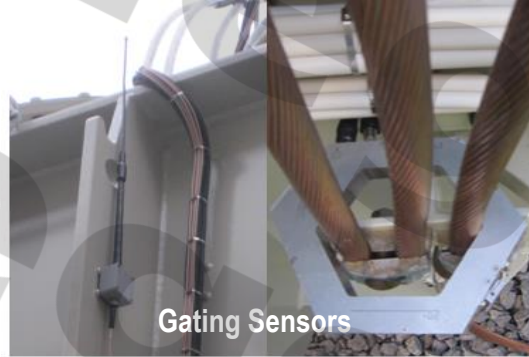

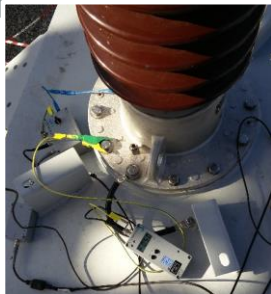

- Matched quadrupole (e.g. CIL4M, CIL5M, ...) → capacitive test tap
- At HV, MV and optionally on the Neutral
- DIN-bushings (LV) & Dry type units → coupling capacitors (CC100B/V)
- Wideband preamplifier (RPA1L) & CAL1D/CAL1B

# Additional decoupling methods for PD-testing

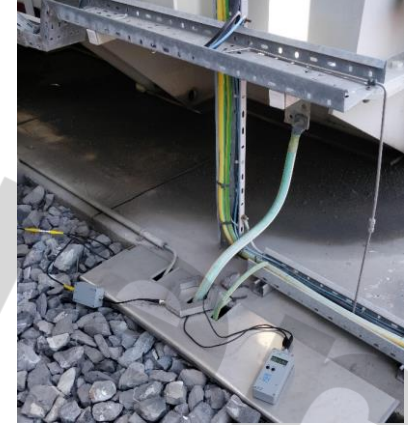
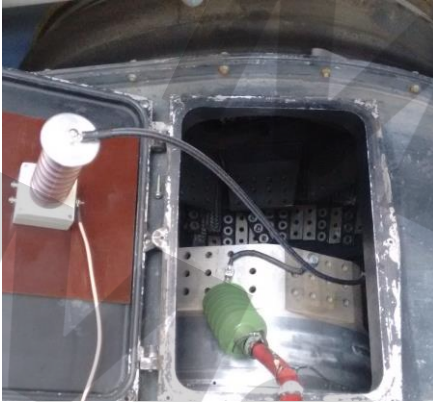

- High frequency current transformers (HFCT's)
- Various coupling capacitors
- UHF drain valve & flange sensors
- Acoustics
- Disturbance antenna's



- Reference ► application teaser questionnaire!
- First line key questions:
  - Reason for the test ? site acceptance or diagnostic?
  - Type of required tests and measurements
  - Transformer rating plate
  - No load losses at rated voltage
  - Bushings details (HV, MV, LV)
  - For condenser bushings (C1 & C2 values)
  - If available, FAT test report
  - In case of a PD-location attempt
    - Outline drawings
    - Internal images of the active part
    - Design drawings

Power Transformers Questionnaire	
Type of Transformer:	<input type="checkbox"/> Auto-transformer <input type="checkbox"/> GSU <input type="checkbox"/> Phase shifter <input type="checkbox"/> Step-down <input type="checkbox"/> Grid transformer <input type="checkbox"/> Other: _____
Rated Voltage (HV/MV/LV)	___ kV / ___ kV / ___ kV
Power Rating (MVA):	
Vector Group:	
No Load Losses at rated voltage (kW):	
Bushings - Primary side:	Type: _____ C1: _____ pF    C2: _____ pF
Bushing - Secondary side:	Type: _____ C1: _____ pF    C2: _____ pF
Bushings - Tertiary Winding:	Type: _____
Purpose of the test:	<input type="checkbox"/> Acoustic PD-location <input type="checkbox"/> Commissioning / Site Acceptance <input type="checkbox"/> Diagnostic Testing <input type="checkbox"/> Other: _____
Type of testing to be performed:	<input type="checkbox"/> Separate Source AC-withstand voltage test Test Level Primary : _____ kV Test Level Secondary : _____ kV Test Level Tertiary : _____ kV <input type="checkbox"/> Three Phases Induced Voltage Test <input type="checkbox"/> Single Phase Induced Voltage Test <input type="checkbox"/> No load Losses Measurement <input type="checkbox"/> Impedance Voltage Tests <input type="checkbox"/> Other: _____
Off-line Partial Discharge Test:	<input type="checkbox"/> Yes <input type="checkbox"/> No
Applicable Standards:	<input type="checkbox"/> IEC 60076-3 ed. 2.0-2000 <input type="checkbox"/> IEC 60076-3 ed. 3.0-2013 <input type="checkbox"/> IEEE C57.12.00 - 2000 <input type="checkbox"/> Other: _____

Power Diagnostix Systems GmbH - Vaalser Strasse 250 - D-52074 Aachen - Phone +49 241 74927 - Fax +49 241 73621 - www.pdix.com

- Questionnaire for PDM on PT
- Spec sheets and manuals
- BCU, BA design specification
- TVS, TFS data sheets

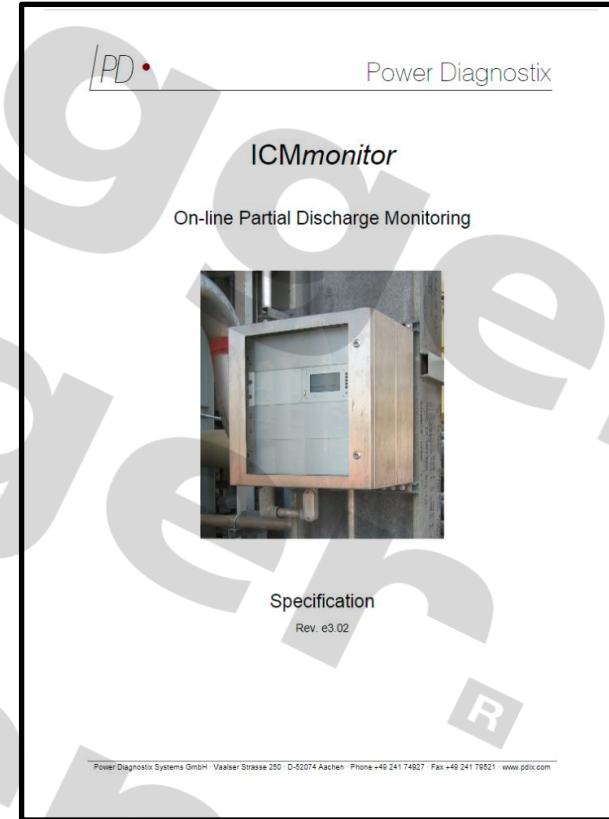

At Power Diagnostics Systems (PDIX) by Megger, we understand that keeping the power on is essential for the success of our customers and our business, hence we are dedicated to creating, designing and manufacturing safe, reliable, easy-to-use Partial Discharge monitoring and testing equipment backed by world-leading support and expertise.

Everyday we assist our customers with monitoring, acceptance, commissioning, testing and maintenance for predictive diagnostic or routine purposes.

By working closely with electrical utilities, standards bodies and technical institutions, we contribute to the dependability and advancement of the electrical supply industry.

