

# Megger®



## SMRT/STVI/RTMS

USER MANUAL

**Model STVI**  
**Smart Touch View Interface –**  
**Handheld Controller**

**Model SMRT 1**  
**Single Phase Relay Test System**

**Model SMRT 1D.**  
**Single Phase Relay Test System**

**Model SMRT 33/36/43/46.**  
**Three Phase Relay Test System**

**Model SMRT 36D.**  
**Three Phase Relay Test System**

**Model SMRT 43/46D**  
**Three Phase Relay Test System**

**Model SMRT 410**  
**Multi-Phase Relay Test System**

**Model SMRT 410D.**  
**Multi-Phase Relay Test System**

**Megger**<sup>®</sup>

### Revision History

<u>Revision</u>	<u>ECN #</u>	<u>Date</u>
1	Initial Release	6/7/2011
2	31676	8/4/2011
3	31736	12/7/2011
4	31882	9/15/2012
5	32089	3/21/2013
6	32124	4/24/2013
7	32289	3/24/2014
8	32621	9/30/2014
9	32781	8/3/2015
10	32933	11/11/2015
11	33187	11/10/2016
12	33312	5/12/2017
13	33419	10/26/2017
14	33489	11/14/2017
15	33557	06/15/2018
16	33690	04/22/2019
17	33806	09/11/2020
18	34391	07/16/2024

### **Declaration of Conformity**

Hereby, Megger Instruments Limited declares that the SMRT/STVI/RTMS, manufactured by Megger Instruments Limited described in this user guide, is following Directive 2014/53/EU. The full text of Megger Instruments EU declarations of conformity is available at the following internet address:

[Megger.com/Company/About-Us/Legal/EU declarations of conformity](http://Megger.com/Company/About-Us/Legal/EU%20declarations%20of%20conformity)

## **IMPORTANT**

This user guide, as well as the hardware and software described in it, is furnished under license, and may be used or copied only in accordance with the terms of such license. The content of this user guide is furnished for informational use only and is subject to change without notice. Megger assumes no responsibility or liability for any errors or inaccuracies that may appear in this user guide.

The information and data in this user guide are proprietary. The equipment described herein may be protected by U.S. patents. Megger specifically reserves all rights to such proprietary information as well as rights under any patent, none of which is waived by the submission of this user guide.

Except as permitted by such license, no part of this publication may be reproduced, stored in a retrieval system, or transmitted, in any form or by any means, electronic, mechanical, recording, or otherwise, without the prior written permission of Megger.

Megger, the Megger logo are trademarks of Megger. All other trademarks are the property of their respective owners.

Notice to U.S. government end users. The hardware, software and documentation are "commercial items," as that term is defined at 48 C.F.R. §2.101, consisting of "commercial computer software" and "commercial computer software documentation," as such terms are used in 48 C.F.R. §12.212 or 48.

C.F.R. §227.7202, as applicable. Consistent with 48 C.F.R. §12.212 or 48 C.F.R. §§227.7202-1 through 227.7202-4, as applicable, the commercial computer software and commercial computer software documentation are being licensed to U.S. government end users (1) only as commercial items and (2) with only those rights as are granted to all other end users pursuant to the terms and conditions set forth in the Megger standard commercial agreement for this software and hardware. Unpublished rights reserved under the copyright laws of the United States. The recipient, if a government agency, acknowledges that this user guide and the equipment described were procured with "Limited Rights" to technical data as described in ASPR 9-203 (b).

The Smart Touch View Interface includes an RTOS-resident computer program. This program belongs to Megger and contains trade secret ideas and information of Megger, written and designed at Megger, 4545 W. Davis, Dallas, Texas 75211-3422 USA

© 2023

### **This document is the copyright of:**

Megger Limited, 4545 W Davis Street Dallas, Texas  
75211-3422 USA PHONE: (800) 723-2861

FAX: (214) 331-7399

[www.megger.com](http://www.megger.com) WEEE

 Waste Electrical and Electronic Equipment - The crossed out wheeled waste bin placed on Megger products is a reminder not to dispose of the product at the end of its life with general waste. Please utilize your Local WEEE collection facilities or observe all applicable Local requirements. Megger is registered in the UK as a Producer of Electrical and Electronic Equipment.

The Registration No is WEE/ DJ2235XR.s

Printed in the USA.

Megger reserves the right to alter the specification of its products from time to time without notice. Although every effort is made to ensure the accuracy of the information contained within this document it is not warranted or represented by Megger Limited to be a complete and up-to-date description.

For Patent information about this instrument refer to the following web site: [megger.com/patent](http://megger.com/patent).



# Your “One Stop” source for all your electrical test equipment needs.

- n Battery Test Equipment
- n Cable Fault Locating Equipment
- n Circuit Breaker Test Equipment
- n Data Communications Test Equipment
- n Fiber Optic Test Equipment
- n Ground Resistance Test Equipment
- n Insulation Power Factor (C&DF) Test Equipment
- n Insulation Resistance Test Equipment
- n Line Testing Equipment
- n Low Resistance Ohmmeters
- n Motor & Phase Rotation Test Equipment
- n Multimeters
- n Oil Test Equipment
- n Portable Appliance & Tool Testers
- n Power Quality Instruments
- n Recloser Test Equipment
- n Relay Test Equipment
- n T1 Network Test Equipment
- n Tachometers & Speed Measuring Instruments
- n TDR Test Equipment
- n Transformer Test Equipment
- n Transmission Impairment Test Equipment
- n Watthour Meter Test Equipment
- n STATES® Terminal Blocks & Test Switches
- n Professional Hands-On Technical and Safety Training Programs

Megger is a leading global manufacturer and supplier of test and measurement instruments used within the electric power, building wiring and telecommunication industries.

With research, engineering and manufacturing facilities in the USA, UK, Germany and Sweden, combined with sales and technical support in most countries, Megger is uniquely placed to meet the needs of its customers worldwide.











Megger is certified according to ISO 9001 and 14001. Megger is a registered trademark.

- |                      |                      |
|----------------------|----------------------|
| n AUSTRALIA          | n POLAND             |
| n BULGARIA           | n ROMANIA            |
| n CANADA             | n RUSSIA             |
| n CZECH REPUBLIC     | n SINGAPORE          |
| n CHINA              | n SLOVAK REPUBLIC    |
| n FRANCE             | n SOUTH AFRICA       |
| n GERMANY            | n SPAIN              |
| n HUNGARY            | n SWEDEN             |
| n INDIA              | n SWITZERLAND        |
| n INDONESIA          | n TAIWAN             |
| n KINGDOM OF BAHRAIN | n THAILAND           |
| n KOREA              | UNITED ARAB EMIRATES |
| n MALAYSIA           | n USA                |
| n PAKISTAN           | n VIETNAM            |
| n PHILIPPINES        |                      |

## SAFETY PRECAUTIONS

### **WARNING: VOLTAGES GENERATED BY THIS INSTRUMENT CAN BE HAZARDOUS**

This instrument has been designed for operator safety; however, no design can completely protect against incorrect use. Electrical circuits are dangerous and can be lethal when lack of caution and poor safety practices are used. There are several standard safety precautions that should be taken by the operator. Where applicable, IEC safety markings have been placed on the instrument to notify the operator to refer to the user manual for instructions on correct use or safety related topics. Refer to the following table of symbols and definitions.

Symbol	Description
	Direct Current
	Alternating Current
	Both direct and alternating current
	Earth (ground) Terminal. There is a common chassis ground terminal located on the front panel (see Front Panel under Description of Controls.
	Protective Conductor Terminal
	Frame or Chassis Terminal
	On (Supply)
	Off (Supply)
	Caution, risk of electric shock
	Caution (refer to accompanying documents)



**WARNING: Under no circumstances should the operator or technician attempt to open or service any Megger instrument while connected to a power source. Lethal voltages are present and may cause serious injury or death!**

## SAFETY PRECAUTIONS (Continued)

The following are specific safety related items associated with the SMRT test system.

Read and understand all safety precautions and operation instructions before attempting to use this unit.

The purpose of this equipment is limited to use as described in this instruction manual. Should a situation arise that is not covered in the general or specific safety precaution please contact Megger regional representative or Megger, Dallas Texas.

Safety is the responsibility of the user. Misuse of this equipment can be extremely dangerous.

Always start with the power OFF, before connecting the power cord. Make sure outputs are off before attempting to make test connections.

Never connect the test set to energized equipment.

Always use properly insulated test leads. The optional test leads are rated for the continuous output ratings of the test system and should be safely used and cared for. DO NOT use cracked or broken test leads.

Always turn the test system off before disconnecting the power cord.

DO NOT attempt to use the unit without a safety ground connected.

DO NOT attempt to use the unit if the power cord ground prong is broken or missing.

DO NOT use the test set in an explosive atmosphere.

Suitably trained and competent people must only use the instrument.

Observe all safety warnings marked on the equipment.

For safety related or other important topics, like the statement below, will be notated with the adjoined symbol. Read the topic carefully as it may relate either to the safe operation of the test system or the safety of the operator.



**Under no circumstances should the operator put their hand or tools inside the test system chassis area with the test system connected to a power source. Lethal voltages are present and may cause serious injury or death!**

# Table of Contents

Section	Page
Model STVI.....	Error! Bookmark not defined.
Smart Touch View Interface - Handheld Controller .....	Error! Bookmark not defined.
Model SMRT1.....	Error! Bookmark not defined.
Single Phase Relay Test System .....	Error! Bookmark not defined.
Model SMRT1D .....	Error! Bookmark not defined.
Single Phase Relay Test System .....	Error! Bookmark not defined.
Model SMRT33/36/43/46.....	Error! Bookmark not defined.
Three Phase Relay Test Systems .....	Error! Bookmark not defined.
Model SMRT36D .....	Error! Bookmark not defined.
Three Phase Relay Test System.....	Error! Bookmark not defined.
Model SMRT43D/46D .....	Error! Bookmark not defined.
Three Phase Relay Test System.....	Error! Bookmark not defined.
Model SMRT410.....	Error! Bookmark not defined.
Multi-Phase Relay Test System .....	Error! Bookmark not defined.
Model SMRT410D .....	Error! Bookmark not defined.
Multi- Phase Relay Test System .....	Error! Bookmark not defined.
<b>Revision History</b> .....	<b>Error! Bookmark not defined.</b>
Written and designed at Megger Limited, 4545 W Davis Street, Dallas, Texas 75211-3422 USA. ....	
<b>Bookmark not defined.</b>	
<b>Safety Precautions</b> .....	6
1.0 <b>Introduction</b> .....	24
1.1 Smart Touch View Interface .....	24
1.2 <b>Terminology</b> .....	26
1.2.1 Acronyms .....	26
1.2.2 Glossary of Terms.....	26
1.2.2.1 Pickup (Tap).....	26
1.2.2.2 TDM (Time Dial Multiple).....	26
1.2.2.3 Inst. (Instantaneous Tap).....	27
1.2.2.4 Reset Seconds .....	27
1.2.2.5 Time Delay .....	27
1.2.2.6 Test Multiple .....	27
1.2.2.7 Reach or Diameter .....	27
1.2.2.8 Angle (Torque).....	27
1.2.2.9 Expected Trip Time .....	28
1.2.2.10 Winding (1,2,3,4) Tap.....	28
1.2.2.11 Percent (%) Slope .....	28
1.2.2.12 Percent (%) Harmonic.....	28
1.2.2.13 Prefault Seconds .....	28
1.3 <b>Power Over Ethernet Input Power</b> .....	28
1.3.1 PoE Power Supply-Input Power Cord .....	28
2.0 <b>SETUP</b> .....	29
2.1 Unpack System.....	29
2.2 <b>Communication Ports</b> .....	30
2.2.1 Ethernet Port.....	30
2.2.2 USB 2.0 Interface.....	30
2.3 <b>RTMS software and STVI Hand-Held Controller</b> .....	30
2.3.1 Configuration.....	32
2.3.1.1 Operation Modes .....	33
2.3.1.2 Battery Simulator .....	33
2.3.1.2.1 Last VIGEN is Battery .....	33

2.3.1.3	Display Versions (Information Screen).....	34
2.3.1.3.1	Command button .....	34
2.3.1.4	Update Firmware .....	34
2.3.1.5	Auto Frequency .....	34
2.3.1.6	Deviation Alarm .....	34
2.3.1.7	Change State Immediately / Change on Zero Cross / Change on Master Zero.....	34
2.3.1.8	Standard Currents button .....	34
2.3.1.9	High Burden Voltage .....	35
2.3.1.10	Analog Mode .....	35
2.3.1.11	Ethernet (DHCP) IP Address.....	35
2.3.1.12	Advanced Mode- Convertible V/I Selection for Multi-Phase Current Output.....	36
2.3.1.13	? Help Button.....	37
2.3.1.14	Phase Angles .....	37
2.3.1.15	Default Settings Options.....	37
2.3.1.15.1	Save as Default.....	38
2.3.1.15.2	Restore Default.....	38
2.3.1.15.3	Restore Factory .....	38
2.3.1.15.4	Restore Factory Hot Environment.....	38
2.3.1.16	Max Amplitudes (Per Channel).....	38
2.3.1.17	Min. Fan Speed % .....	38
2.3.1.18	IRIG .....	38
2.3.1.19	Fault Labels (ABC) .....	38
2.3.1.20	Language.....	39
2.3.1.21	Color Options.....	39
2.3.1.22	Symmetrical Components .....	39
2.3.1.23	Voltage Character.....	39
2.3.1.25	Set Date and Time.....	39
2.3.1.26	Logging.....	39
2.3.1.27	Adjust Screen Brightness .....	39
2.3.1.28	CT/PT Ratios .....	39
2.3.1.29	Low Level Outputs.....	41
2.3.1.29.1	Low Output Current Generator 0-50 mA / Rogowski .....	42
2.3.1.29.2	Low Voltage .....	44
2.3.1.30	Use PRO Header.....	45
2.3.1.31	Update Translations .....	45
2.3.1.32	Contact Names (Global).....	45
2.3.1.33	Default As Found/As Left.....	45
2.3.1.34	ANSI / IEC Button.....	46
2.3.1.35	Flyover Text Button .....	46
2.3.1.36	Voltage Resolution (.01) Button.....	46
2.3.1.37	TCC Curve Import Button .....	46
2.3.1.38	Multi-Instance Button.....	46
2.3.1.39	Script Import/Export Button .....	46
2.3.1.40	Screen Exit .....	46
2.4	<b>Setting Amplitudes, Phase Angle or Frequency</b> .....	46
2.4.1	Numeric Keypad Entry .....	46
2.4.2	Include Channel in Ramping .....	47
2.4.3	Control Knob .....	48
2.4.4	Setting Default Voltage Outputs.....	48
2.4.5	Setting Default Current Outputs.....	48
2.4.6	Virtual Alphanumeric Keypad.....	49
2.5	<b>RTMS software File Management</b> .....	49
3.0	<b>RTMS software – Basic Operating Descriptions</b> .....	50
3.1	<b>Manual Test Screen</b> .....	51
3.1.1	Connection button .....	51

3.1.2	The Configuration button.....	51
3.1.3	Battery Simulator button.....	51
3.1.4	Report options button.....	52
3.1.5	File Folder button.....	52
3.1.6	Relay Settings button.....	52
3.1.6.1	Relay Settings Import/Export Options.....	52
3.1.6.1.1	Read From Relay.....	52
3.1.6.1.1.1	Read From SEL Relay.....	52
3.1.6.1.1.2	Read From Modbus Relay.....	54
3.1.6.1.1.2.1	Read From Modbus Relay with Serial Communications.....	55
3.1.6.1.1.2.2	Read From Modbus Relay with Ethernet Communications.....	55
3.1.6.1.2	Import XRIO File.....	56
3.1.6.1.3	Import TEAX File.....	56
3.1.6.1.4	Import SEL RDB Txt File.....	56
3.1.6.1.5	Import ERL L-PRO File.....	57
3.1.6.1.6	Import ERL T-PRO File.....	57
3.1.6.1.7	Import CSV File.....	57
3.1.6.1.8	Export RTMS to CSV File.....	57
3.1.6.1.9	Import XML File.....	58
3.1.6.2	Relay Settings Import/Export Edit Mode Enabled.....	58
3.1.6.2.1	Create New Relay Settings.....	58
3.1.6.2.2	Edit Imported Settings.....	59
3.1.7	Select New Test button.....	61
3.1.7.1	Ramp Selection buttons.....	62
3.1.7.2	Timing Test buttons.....	62
3.1.7.3	Sequence 1,2,3..9 button.....	62
3.1.7.4	Impedance button.....	63
3.1.7.5	Differential button.....	63
3.1.7.6	Megger GOOSE Configurator button.....	63
3.1.7.7	Megger Sampled Values Configurator button.....	63
3.1.7.8	Transducer button.....	63
3.1.7.9	Meter button.....	63
3.1.7.10	Synchronizer button.....	63
3.1.7.11	Frequency button.....	64
3.1.7.12	COMTRADE button.....	64
3.1.7.13	Power Swing button.....	64
3.1.7.14	SS1 button.....	64
3.1.8	Relay Library button.....	64
3.1.8.1	Select Relay Manufacturer button.....	64
3.1.8.2	Template Manager button.....	65
3.1.8.2.1	Update Local With Newer button.....	65
3.1.8.2.2	Update Local With Missing Only button.....	66
3.1.8.2.3	Update Local With Checked button.....	66
3.1.8.2.4	Open in RTMS button.....	66
3.1.9	Predefined Test button.....	66
3.1.9.1	Run button.....	68
3.1.9.2	Run All button.....	68
3.1.9.3	View Results button.....	69
3.1.9.4	Go To Test Screen button.....	69
3.1.9.5	View / Edit Notes button.....	69
3.1.9.6	Help button.....	70
3.1.9.7	Edit Test Attribute Script button.....	70
3.1.9.8	Extended Actions List button.....	71
3.1.10	Help button.....	72
3.1.10.1	System Reset button.....	72

3.1.11	Phase Vector Screen.....	72
3.1.12	Binary Input Dialog Box.....	72
3.1.12.1	More button.....	74
3.1.12.1.1	Simple Mode button.....	74
3.1.12.1.2	Advanced button.....	74
3.1.12.1.2.1	Harmonic Waveform selection button.....	74
3.1.12.1.3	Custom button.....	75
3.1.12.1.4	Symmetrical button.....	75
3.1.12.1.5	Power button.....	75
3.1.12.1.6	Phase to Phase Voltage DisRun button.....	76
3.1.12.1.7	Impedance DisRun button.....	76
3.1.12.1.8	Secondary Values button.....	76
3.1.13	Maximum Test Time/Prefault Time/Post Fault Time Settings button.....	77
3.1.14	Run Test button.....	77
3.1.15	Prefault / Fault buttons.....	78
3.1.16	All ON/All OFF button.....	78
3.1.17	Manual Ramp Options button.....	78
3.1.18	Channel ON/OFF selector button.....	78
3.1.19	Fault Calculator button.....	78
3.1.19.1	Mode Selection button.....	78
3.1.19.1.1	Overcurrent Mode button.....	79
3.1.19.1.2	Voltage Mode button.....	79
3.1.19.1.3	Frequency Mode button.....	80
3.1.19.1.4	Impedance Mode button.....	80
3.1.19.1.4.1	Fault Selection button.....	80
3.1.19.1.4.2	Test Model button.....	80
3.1.19.1.4.3	Compensation button.....	81
3.1.19.1.5	Symmetrical Mode button.....	81
3.1.19.1.6	Power Swing Mode button.....	82
3.1.19.1.7	Fault Location button.....	84
3.1.19.2	Fault Type Selection button.....	84
3.1.20	Channel Amplitude, Phase Angle and Frequency buttons.....	85
3.2	<b>Setting Phase Angle Relationships</b> .....	85
3.3	<b>Current Sources</b> .....	86
3.3.1	<b>Parallel Operation</b> .....	86
3.3.1.1	Manual Test Screen - Single Phase Up To180 Ampere.....	87
3.3.2	<b>Currents in Series Operation</b> .....	89
3.4	<b>Voltage Sources</b> .....	90
3.4.1	Outputs Summed Together.....	90
3.4.2	<b>3Ø, 3-Wire, Open-Delta and T-Connection</b> .....	91
3.4.2.1	Balanced Open Delta.....	91
3.4.2.1.1	Unbalanced Open Delta.....	93
3.4.2.2	T-Connection.....	94
3.4.3	<b>3Ø, 4-Wire, Y-Connection</b> .....	94
3.5	<b>Testing Relays with the Manual Test Screen</b> .....	96
3.5.1	Simple Manual Pickup or Dropout Test.....	96
3.5.2	Simple Manual Timing Test.....	97
3.5.3	<b>Simple Ramp Test</b> .....	99
3.5.3.1	Configuring of Multiple Ramps.....	101
3.5.3.2	Step Ramp Example.....	101
3.5.3.3	Pulse Ramp Example.....	102
3.5.3.4	Pulse Ramp Binary Search Example.....	103
3.5.3.5	EM (Electromechanical) Overcurrent Pickup Example.....	103
3.5.3.6	Instantaneous Pickup Example.....	105
3.5.4	<b>Advanced Ramp Test</b> .....	105

3.5.4.1	Setting Values .....	106
3.5.4.1.1	Show Pre-fault Conditions button .....	106
3.5.4.1.2	Show Ramp Start button .....	106
3.5.4.1.3	Show Ramp Increment button .....	106
3.5.4.1.4	Show Ramp End button .....	106
3.5.4.2	Smooth Ramp.....	107
3.5.5	<b>Ramping Battery Simulator Output</b> .....	107
3.5.6	<b>Overcurrent Tests</b> .....	107
3.5.6.1	Curve Selection Button .....	110
3.5.6.1.1	Manufacturer's Model Button .....	110
3.5.6.1.2	Relay's Curve and Direction per Element – Selection and Configuration.....	111
3.5.6.1.3	Run Test Screen .....	115
3.5.6.1.3.1	Change Test Button .....	115
3.5.6.1.3.2	Relay Settings Button .....	116
3.5.6.1.5.3	Battery Simulator Button .....	116
3.5.6.1.5.4	Binary Input Setting button.....	116
3.5.6.1.5.5	Report Options button.....	116
3.5.6.1.5.6	Run a Predefined Test button .....	116
3.5.6.1.6	Performing Tests.....	116
3.5.6.1.6.1	Phase Pickup Button.....	117
3.5.6.1.6.2	Phase Timing Button.....	117
3.5.6.1.6.3	Phase Instantaneous Button .....	118
3.5.6.1.6.4	Phase Directional Button .....	118
3.5.6.1.6.4.1	Phase Directional Shot Button .....	119
3.5.6.1.6.5	Ground Pickup Button.....	120
3.5.6.1.6.6	Ground Timing Button.....	120
3.5.6.1.6.7	Ground Instantaneous Button .....	121
3.5.6.1.6.8	Ground Directional Button.....	121
3.5.6.1.6.8.1	Ground Directional Shot Button.....	122
3.5.6.1.6.9	Ground DC Target and Seal-In Button.....	123
3.5.7	<b>Testing Over Voltage Relays</b> .....	123
3.5.7.1	Manufacturer Selection Button .....	125
3.5.7.2	Manufacturer's Model Button.....	125
3.5.7.3	Run Test Screen.....	126
3.5.7.3.1	Change Test Button .....	126
3.5.7.3.2	Relay Settings Button .....	127
3.5.7.3.3	Battery Simulator Button .....	127
3.5.7.3.4	Binary Input Setting button.....	127
3.5.7.3.5	Report Options button.....	127
3.5.7.3.6	Run Predefined Test button .....	127
3.5.7.4	Performing Tests .....	127
3.5.7.4.1	Phase Pickup Button.....	127
3.5.7.4.2	Phase Timing Button.....	128
3.5.7.4.3	Phase Instantaneous Button.....	129
3.5.8	<b>Testing Under Voltage Relays</b> .....	129
3.5.8.1	Manufacturer Selection Button .....	131
3.5.8.2	Manufacturer's Model Button.....	131
3.5.8.3	Run Test Screen.....	132
3.5.8.3.1	Change Test Button .....	132
3.5.8.3.2	Relay Settings Button .....	133
3.5.8.3.3	Battery Simulator Button .....	133
3.5.8.3.4	Binary Input Setting button.....	133
3.5.8.3.5	View Test Results button .....	133
3.5.8.3.6	Run Predefined Test button .....	133
3.5.8.4	Performing Tests .....	133

3.5.8.4.1	Phase Pickup Button.....	133
3.5.8.4.2	Phase Timing Button.....	134
3.5.9	<b>State Sequencer Test.....</b>	<b>135</b>
3.5.9.1	Reclosing Relay Testing.....	135
3.5.9.2	Transient Earth-Fault (TEF) Simulator .....	140
3.5.9.2.1	Transient Earth-Fault Relay Settings .....	141
3.5.9.2.2	Transient Earth-Fault Test Settings .....	142
3.5.9.2.3	Performing Transient Earth-Fault Test.....	142
3.6	<b>Testing Impedance Relays.....</b>	<b>143</b>
3.6.1	<b>Common Settings .....</b>	<b>143</b>
3.6.1.1	Tolerance Settings.....	144
3.6.1.2	Zone Trip Time Settings .....	144
3.6.1.3	DIRECTION Setting Button .....	144
3.6.1.4	Zones/Fault Selection Box.....	144
3.6.1.5	Ground Compensation Settings .....	145
3.6.1.6	CT PT Ratios.....	146
3.6.2	<b>Generic Characteristics.....</b>	<b>146</b>
3.6.2.1	Generic MHO Setting Screen .....	147
3.6.2.1.1	MHO Load Encroachment Setting Screen.....	147
3.6.2.2	HALF CIRCLE Setting Screen.....	148
3.6.2.3	QUAD Setting Screen.....	149
3.6.2.3.1	QUAD Load Encroachment Setting Screen.....	149
3.6.2.4	IEEE QUAD Setting Screen .....	150
3.6.2.4.1	IEEE QUAD Load Encroachment Setting Screen.....	151
3.6.3	<b>Impedance Relay Library Files .....</b>	<b>152</b>
3.6.4	<b>MCE / RIO Files.....</b>	<b>153</b>
3.6.5	<b>Impedance - Click On Fault Configuration Screen .....</b>	<b>153</b>
3.6.5.1	Prefault Dialog Box.....	154
3.6.5.2	Control Dialog Box.....	154
3.6.5.3	Ramp/Shot Options .....	154
3.6.5.4	CT PT Ratios.....	155
3.6.5.5	Polar/Rectangular Plot Button .....	155
3.6.5.6	Auto Set Fault Times button .....	155
3.6.5.7	Ohms Per Phase/Per Loop button.....	155
3.6.5.8	Report Options button .....	155
3.6.5.8.1	Adding Z/t Chart to Report.....	156
3.6.5.9	Five Degree Snap button.....	156
3.6.6	<b>Impedance - Click On Fault Test Screen.....</b>	<b>156</b>
3.6.6.1	Home button .....	157
3.6.6.2	Configuration button .....	157
3.6.6.3	Battery Simulator button .....	157
3.6.6.4	Review Test Report button .....	157
3.6.6.5	Binary Input Setting button .....	157
3.6.6.6	Relay Settings Button .....	158
3.6.6.7	RIO button .....	158
3.6.6.8	Relay Library button .....	158
3.6.6.9	Zoom button .....	158
3.6.6.10	Run Predefined Test button.....	158
3.6.6.11	Run button .....	159
3.6.6.12	Test All button.....	159
3.6.6.13	Help button .....	159
3.6.6.14	Change Search Mode button.....	159
3.6.6.14.1	IEC60255 Test Points Mode .....	160
3.6.6.14.2	Origin Test Points Mode .....	160
3.6.6.14.3	Shots Test Points option .....	160

3.6.6.15	Quick Test – Auto Generate Test Points .....	160
3.6.6.16	Clear Test Lines button.....	161
3.6.6.17	Clear Results button .....	162
3.6.6.18	Return to Characteristic Settings Screen button .....	162
3.6.6.19	Fault Selection button .....	162
3.6.7	<b>Easy Z Impedance Relay Test</b> .....	162
3.6.7.1	Easy Z Impedance Relay Setting and Test Screen.....	163
3.6.7.1.1	Binary Input Setting button.....	163
3.6.7.1.2	CT Earthing Position button .....	164
3.6.7.1.3	The Configuration button .....	164
3.6.7.1.4	Report options button.....	164
3.6.7.1.5	Review Test Report button .....	164
3.6.7.1.6	Clear Test(s) button .....	164
3.6.7.1.7	Clear Test Results button .....	165
3.6.7.1.8	Test Method Selection Box.....	165
3.6.7.1.9	Fault Type Selection button .....	165
3.6.7.1.10	Ground Compensation.....	165
3.6.7.1.11	Fault Setting Fields .....	166
3.6.7.1.12	Pre-Fault, Fault, Post Fault dialog box.....	166
3.6.7.1.13	Impedance Ramp box.....	167
3.6.7.1.14	Impedance Test Screen.....	168
3.6.7.1.15	Impedance Plane Screen.....	168
3.6.8	<b>Unknown Impedance Characteristic</b> .....	169
3.6.8.1	Prefault Dialog Box.....	169
3.6.8.2	Control Dialog Box.....	169
3.6.8.3	CT PT Ratios .....	170
3.6.8.4	Relay Button .....	170
3.6.8.5	Ramp Options.....	171
3.6.8.6	Search Options.....	171
3.6.8.7	Unknown Impedance Relay Test Screen .....	171
3.6.8.7.1	RIO button.....	172
3.6.8.7.2	Configuration button.....	172
3.6.8.7.3	Battery Simulator button .....	172
3.6.8.7.4	Review Test Report button .....	172
3.6.8.7.5	Binary Input Setting button.....	172
3.6.8.7.6	Relay Settings Button .....	173
3.6.8.7.7	Zoom button.....	173
3.6.8.7.8	Run Predefined Test button .....	173
3.6.8.7.9	Run button .....	173
3.6.8.7.10	Help button.....	173
3.6.8.7.11	Fault Selection button .....	174
3.6.9	<b>Megger Characteristic Editor</b> .....	174
3.6.9.1	Distance Parameters Settings .....	175
3.6.9.1.1	System Settings .....	175
3.6.9.1.2	Tolerance settings.....	175
3.6.9.1.3	Grounding Factors .....	176
3.6.9.2	Device Parameters .....	176
3.6.9.3	Fault Selection Boxes.....	177
3.6.9.4	Impedance Plane Screen .....	177
3.6.9.5	Zone Selection Box .....	177
3.6.9.6	Segment # <i>n</i> .....	177
3.6.9.7	Add Segment button.....	178
3.6.9.8	Autoclose button.....	178
3.6.9.9	Flip Operation button .....	178
3.6.9.10	Defining Impedance Operations Row.....	179

3.6.9.11	Creating Impedance Characteristics .....	179
3.7	<b>Testing Transducers with the STVI Software</b> .....	182
3.7.1	<b>Transducer Setup Screen</b> .....	183
3.7.1.1	Nameplate Section .....	183
3.7.1.2	Type Selection Section.....	183
3.7.1.3	Test Settings Section.....	184
3.7.1.4	Input Range Section.....	185
3.7.1.5	Output Range Section .....	185
3.7.2	<b>Transducer Test Screen</b> .....	186
3.7.2.1	Output Section.....	186
3.7.2.2	Transducer Output Section.....	187
3.7.3	<b>Testing Transducers</b> .....	187
3.7.4	<b>Saving Results</b> .....	188
3.7.5	<b>Watt / Var / Va / Power Factor Applications</b> .....	188
3.7.5.1	Watt/VAR 1 Element.....	188
3.7.5.2	Power Factor 1 Element .....	190
3.7.5.3	Watt/VAR1 1/2 Element.....	191
3.7.5.4	Watt/VAR 2 Element.....	192
3.7.5.5	Watt/VAR 2 1/2 Element.....	194
3.7.5.6	Watt/VAR 3 Element.....	196
3.7.5.7	Power Factor 3 Element .....	198
3.7.6	<b>Single Phase Applications</b> .....	200
3.7.6.1	AC and DC Voltage Transducers .....	200
3.7.6.2	AC and DC Current Transducers .....	201
3.7.6.3	Frequency Transducers.....	202
3.8	<b>Meter Test</b> .....	202
3.9	<b>Testing Differential Relays</b> .....	204
3.9.1	<b>Transformer Nameplate</b> .....	205
3.9.2	<b>Transformer Differential Tests</b> .....	215
3.9.2.1	Stablization Test .....	216
3.9.2.2	Timing Test.....	216
3.9.2.3	Pickup Test.....	217
3.9.2.4	Slope Test .....	218
3.9.2.4.1	Characteristic Shot Test .....	220
3.9.2.5	Harmonic Block Test .....	220
3.9.2.6	Harmonic Shot Test.....	221
3.10	<b>Synchronizer Test</b> .....	222
3.10.1	Synchronizer Relay Settings and Configuration Screen .....	223
3.10.1.1	Device Nameplate – System Settings .....	223
3.10.2	Circuit Breaker Settings .....	223
3.10.3	Synchronization Characteristic Settings.....	223
3.10.4	Test Parameters.....	224
3.10.5	Synchronizer Characteristic Test Selection Screen .....	224
3.10.5.1	The Configuration button .....	224
3.10.5.2	Battery Simulator button .....	225
3.10.5.3	Test Report button .....	225
3.10.5.4	Return to Synchronizer Relay Settings and Configuration Screen button.....	225
3.10.5.5	Binary Input Setting button .....	225
3.10.5.6	Relay Library button .....	225
3.10.5.7	Predefined Test button .....	226
3.10.5.8	Run Test button .....	226
3.10.5.9	Run All Tests button .....	226
3.10.5.10	Help button.....	226
3.10.5.11	Quick Test option .....	226
3.10.5.12	Dynamic Points option .....	227

3.10.5.13	Origin Test Points option.....	227
3.11	<b>Frequency Test</b> .....	227
3.11.1	Frequency Relay Settings and Configuration Screen .....	227
3.11.1.1	Under Frequency Relay Test Settings.....	228
3.11.1.2	Over Frequency Relay Test Settings.....	230
3.11.1.3	df/dt ROCOF Relay Test Settings.....	232
3.11.1.4	VT and Relay Connections.....	233
3.11.1.5	Classic Timing Test Selection .....	233
3.11.1.6	Prefault Settings .....	234
3.11.2	Frequency Relay Test Screen.....	234
3.11.2.1	The Configuration button .....	234
3.11.2.2	Battery Simulator button .....	234
3.11.2.3	Test Report button .....	234
3.11.2.4	Test List button .....	235
3.11.2.5	Return to Frequency Relay Test Settings Screen button .....	235
3.11.2.6	Run Predefined Test button.....	235
3.11.2.7	Run Test button .....	235
3.11.2.8	Help button .....	235
3.11.3	Frequency Relay Pickup Test Screen.....	235
3.11.4	Frequency Relay Timing Test Screen.....	236
3.12	<b>COMTRADE Playback</b> .....	236
3.12.1	COMTRADE Dialog Box .....	236
3.12.1.1	Processing a COMTRADE File .....	237
3.12.2	COMTRADE Test Screen .....	237
3.12.2.1	The Home button .....	238
3.12.2.2	Configuration Screen button.....	238
3.12.2.3	Open COMTRADE File button .....	238
3.12.2.4	COMTRADE Waveform View button .....	238
3.12.2.5	Report Option button .....	238
3.12.2.6	Configure Timer button.....	239
3.12.2.7	Sample Rate.....	240
3.12.2.8	# Samples.....	240
3.12.2.9	Battery Simulator button .....	240
3.12.2.10	Start Now button .....	240
3.12.2.11	Binary Input Setting button.....	241
3.12.2.12	Run Predefined Test button .....	241
3.12.2.13	Run button .....	241
3.12.2.14	Help button.....	241
3.12.2.15	Pre Fault time window.....	241
3.12.2.16	Iterations window .....	241
3.12.2.17	Analog Voltage and Current Values.....	242
3.12.2.18	Digital Channels.....	242
3.12.3	Processing the COMTRADE File .....	242
3.12.3.1	Adding Digital channel playback.....	243
3.12.3.2	Viewing COMTRADE Playback Waveforms.....	244
3.12.3.2.1	Zoom and Cursor Controls.....	245
3.12.3.2.2	Cropping button .....	246
3.12.3.3	Saving Test.....	246
3.13	<b>Power Swing and Out of Step Simulator</b> .....	246
3.13.1	Power Swing Test Screen.....	247
3.14	<b>SS1 File Playback</b> .....	250
3.14.1	SS1 File Pre-Test Dialog Window.....	250
3.14.1.1	Run Immediately button.....	251
3.14.1.1.1	Run button .....	251
3.14.1.1.2	Run All button .....	252

3.14.1.1.3	View Results button .....	252
3.14.1.1.4	Go To Test Screen button.....	252
3.14.1.1.5	View / Edit Notes button.....	252
3.14.1.1.6	Help button.....	253
3.14.1.1.7	Edit Test Attribute Script button .....	254
3.14.1.1.8	Extended Actions List button .....	254
3.14.1.2	Wait on IRIG-B .....	255
3.14.1.3	Wait Contact.....	256
3.15	<b>IEC 61850 Megger GOOSE Configurator (MGC)</b> .....	256
3.15.1	GOOSE Message Description .....	256
3.15.1.1	IEC 61850 Relay Testing – General Description.....	257
3.15.2	MGC Menus .....	258
3.15.2.1	File Tab.....	258
3.15.2.1.1	Save.....	258
3.15.2.1.2	Save As.....	258
3.15.2.1.3	Open .....	258
3.15.2.1.4	Download Settings to Test Set.....	259
3.15.2.1.5	Exit.....	259
3.15.2.2	Edit Tab .....	259
3.15.2.2.1	Delete Selected GOOSE .....	259
3.15.2.2.2	Mark Unconfirmed (All GOOSE messages this tab).....	259
3.15.2.2.3	Reset Binary Input Mapping.....	259
3.15.2.2.4	Reset Binary Output Mapping.....	259
3.15.2.2.5	Reset All Binary Input / Output Mappings .....	259
3.15.2.2.6	Delete Current Tab .....	259
3.15.2.3	View Tab.....	260
3.15.2.3.1	Collapse All .....	260
3.15.2.3.2	Expand All.....	260
3.15.2.3.3	Open Log .....	260
3.15.2.4	Tools Tab.....	260
3.15.2.4.1	Capture .....	260
3.15.2.4.2	Import.....	260
3.15.2.4.3	Sort .....	261
3.15.2.4.4	Reset GOOSE Configuration .....	261
3.15.2.4.5	Select Network Device.....	261
3.15.2.4.6	Set Test Set IP .....	261
3.15.2.4.7	Preference .....	261
3.15.2.4.7.1	Full View.....	262
3.15.2.4.7.2	Easy View.....	262
3.15.2.4.7.3	FREJA 4xx Mode .....	263
3.15.2.4.7.4	SMRT/MPRT Mode .....	263
3.15.2.4.7.5	PC-GOOSER Mode .....	263
3.15.2.4.7.6	Expanded MPRT Mode.....	263
3.15.2.4.7.7	Bypass Test Set Connection .....	264
3.15.2.5	GOOSE Filter Options .....	264
3.15.2.5.1	Delete On Add To Filter .....	265
3.15.2.5.2	Filter Allows Update .....	265
3.15.2.5.3	VLAN ID .....	265
3.15.2.5.4	GOOSE Test Attribute ED. 1. ....	265
3.15.2.6	Test Tab.....	266
3.15.2.6.1	IEC 61850-8-1 Ed. 1 Test .....	266
3.15.2.7	Help Tab .....	266
3.15.3	MGC Toolbar.....	266
3.15.3.1	SCL Button .....	266
3.15.3.2	C Button.....	267

3.15.3.3	DL Button.....	267
3.15.3.4	MERGE Button.....	267
3.15.3.5	COMPARE Button.....	267
3.15.3.6	Copy to MyGOOSE Button.....	267
3.15.3.7	New Search Button.....	267
3.15.4	Network Scanning.....	268
3.15.4.1	How to capture GOOSE Messages.....	268
3.15.4.2	How to Monitor GOOSE Messages.....	270
3.15.5	GOOSE Message Analysis.....	271
3.15.5.1	GOOSE Filter.....	271
3.15.5.2	MERGE.....	271
3.15.5.3	COMPARE.....	271
3.15.5.4	Confirmation.....	272
3.15.6	Merging of GOOSE messages.....	272
3.15.6.1	MERGE and COMPARE example.....	272
3.15.6.2	COMPARE example.....	276
3.15.7	Configuration.....	278
3.15.7.1	Mapping SMRT / FREJA 5xx binary inputs to GOOSE messages (subscription).....	279
3.15.7.2	Mapping SMRT / FREJA 5xx binary outputs to GOOSE messages (publication).....	281
3.15.7.3	Manipulating the IEC-61850 test service parameter in published GOOSE messages.....	281
3.15.7.4	Manipulating the IEC-61850 test attribute in the quality parameter in the published GOOSE messages by the SMRT / FREJA 5xx.....	283
3.16	<b>IEC 61850-9-2 Megger SVA Configurator (SVA)</b> .....	284
3.16.1	Testing Relays with Sampled Values.....	284
3.16.2	SVA Menu.....	284
3.16.2.1	SVA File.....	285
3.16.2.1.1	New File.....	285
3.16.2.1.2	Open File.....	285
3.16.2.1.3	Save File.....	285
3.16.2.1.4	Save As File.....	285
3.16.2.1.5	Exit.....	285
3.16.3	SV Configurator.....	285
3.16.3.1	MAC.....	286
3.16.3.2	VLAN ID (int).....	286
3.16.3.3	VLAN Priority (int).....	286
3.16.3.4	APP ID (4 octets).....	286
3.16.3.5	SV Quality (8 octets).....	286
3.16.3.6	CT Ratio (int).....	286
3.16.3.7	PT Ratio (int).....	286
3.16.3.8	SV ID.....	286
3.16.3.9	Config Rev (int).....	287
3.16.3.10	SYNC.....	287
3.16.3.11	SV Channel Map.....	287
3.16.3.11.1	No Mapping.....	287
3.16.3.11.2	I1 – I4: V1 – V4.....	287
3.16.3.11.3	I5 – I8: V5 – V8.....	287
3.16.3.11.4	I9 – I12: V9 – V12.....	287
3.16.3.12	Test Set IP Adress.....	287
3.16.3.13	Download SV Configuration.....	287
3.16.4	SV Snapshot.....	287
3.16.4.1	Network Interface.....	288
3.16.4.2	Start button.....	288
3.16.4.3	Stop button.....	288
3.16.4.4	Clear All button.....	289
3.16.5	SV Viewer.....	289

3.16.5.1	Start button .....	289
3.16.5.1.1	Enable/Disable Analog Channels .....	290
3.16.5.2	Current and Voltage Measurement Options .....	290
3.16.5.3	Viewing Data .....	291
4.0	<b>Warranty Statement</b> .....	292
5.0	<b>Service Data</b> .....	293
5.1	<b>Preventive Maintenance</b> .....	293
5.1.1	Examine the Unit .....	293
5.1.2	Upgrading the STVI Software .....	293
5.2	<b>Service and Repair Instructions</b> .....	295
5.2.1	Basic Troubleshooting .....	295
5.2.1.1	Power Input .....	295
5.2.1.2	Ethernet Cable .....	295
1.2.1.	<b>Input Power Cord</b> .....	296
6.0	<b>Preparation for Reshipment</b> .....	297
	<b>Addendum A SMRT1</b> .....	298
1.0	<b>Operation</b> .....	299
1.1	<b>General Description</b> .....	299
1.1.1	Front Panel .....	299
1.1.2	Side Panel .....	300
1.1.3	Rack Mount Enclosure Rear Panel .....	300
1.2	<b>Input Power</b> .....	301
1.2.1.	Input Power Cord .....	302
1.3	<b>Voltage Current Generator (VIGEN) Module</b> .....	302
1.3.1.	Convertible Voltage/Current Amplifier .....	302
1.3.2.	Current Amplifier .....	303
1.4	<b>Binary Input and Output</b> .....	304
1.4.1	Binary Inputs .....	304
1.4.1.1	Start, Stop, and Monitor Gates .....	304
1.4.1.1.1	Dry Contacts Open .....	304
1.4.1.1.2	Dry Contacts Close .....	304
1.4.1.1.3	Application or Removal of AC or DC voltage .....	305
1.4.2	Binary Outputs .....	305
2.0	<b>SETUP</b> .....	305
2.1	Unpack System .....	305
2.2	<b>Communication Ports</b> .....	305
2.2.1	PC IN Ethernet Port .....	306
2.2.1.1	Setting SMRT IP Address for Operation with a PC .....	306
2.2.1.2	Setting SMRT IP Address for Networks .....	307
2.2.2	61850/OUT Ethernet Port .....	307
2.2.2.1	IEC 61850 Operations .....	308
3.1	Parallel Operation .....	308
3.1.1	Manual Test Screen - Single Phase Up To180 Ampere .....	309
3.2	Currents in Series Operation .....	310
4.0	<b>Voltage Sources</b> .....	310
4.1	<b>Outputs Summed Together</b> .....	310
4.2	3Ø, 3-Wire, Open-Delta and T-Connection .....	311
4.2.1	Balanced Open Delta .....	311
4.2.2	T-Connection .....	311
4.3	<b>3Ø, 4-Wire, Y-Connection</b> .....	312
5.1.1	Examine the Unit .....	312
	<b>Addendum B SMRT1D</b> .....	313
	<b>Safety Precautions</b> .....	313
1.0	<b>Operation</b> .....	314
1.1	<b>General Description</b> .....	314

1.1.1	Top Panel.....	314
1.1.2	Front Panel.....	315
1.2	<b>Input Power</b> .....	316
1.2.1.	Input Power Cord.....	316
1.3	<b>Voltage Current Generator (VIGEN) Module</b> .....	317
1.3.1.	Convertible Voltage/Current Amplifier.....	317
1.3.2.	Current Amplifier.....	318
1.4	<b>Binary Inputs and Outputs</b> .....	318
1.4.1	Binary Inputs.....	318
1.4.1.1	Start, Stop, and Monitor Gates.....	319
1.4.1.1.1	Dry Contacts Open.....	319
1.4.1.1.2	Dry Contacts Close.....	319
1.4.1.1.3	Application or Removal of AC or DC voltage.....	319
1.4.2	Binary Outputs.....	319
2.0	<b>SETUP</b> .....	319
2.1	Unpack System.....	319
2.2	<b>Communication Ports</b> .....	320
2.2.1	USB 3.0 Interface.....	320
2.2.2	IN Ethernet Port.....	321
2.2.2.1	Setting SMRT IP Address for Operation with a PC.....	321
2.2.3	IN Ethernet Port.....	322
2.2.4	IEC61850 / OUT Ethernet Port.....	322
2.2.4.1	Setting SMRT IP Address for Networks or IEC 61850 Operations.....	323
3.1	<b>Parallel Operation</b> .....	323
3.1.1	Manual Test Screen - Single Phase Up To180 Ampere.....	324
3.2	Currents in Series Operation.....	324
4.0	<b>Voltage Sources</b> .....	325
4.1	Outputs Summed Together.....	325
4.2	3Ø, 3-Wire, Open-Delta.....	326
4.2.1	Balanced Open Delta.....	326
	<b>Addendum C SMRT33/36/43/46</b> .....	327
	<b>Safety Precautions</b> .....	327
1.0	<b>Operation</b> .....	328
1.1	<b>General Description</b> .....	328
1.1.1	Top Panel.....	328
1.1.2	Front Panel.....	330
1.2	<b>Input Power</b> .....	331
1.2.1.	Input Power Cord.....	331
1.3	<b>Voltage Current Generator (VIGEN) Module</b> .....	332
1.3.1.	Convertible Voltage/Current Amplifier.....	332
1.3.2.	Current Amplifier.....	332
1.4	<b>Binary Inputs and Outputs</b> .....	333
1.4.1	Binary Inputs.....	334
1.4.1.1	Start, Stop, and Monitor Gates.....	334
1.4.1.1.1	Dry Contacts Open.....	334
1.4.1.1.2	Dry Contacts Close.....	334
1.4.1.1.3	Application or Removal of AC or DC voltage.....	334
1.4.2	Binary Outputs.....	335
1.5	<b>Battery Simulator</b> .....	335
2.0	<b>SETUP</b> .....	335
2.1	Unpack System.....	335
2.2	<b>Communication Ports</b> .....	336
2.2.1	USB 2.0 Interface.....	336
2.2.2	PC/OUT Ethernet Port.....	337
2.2.2.1	Setting SMRT IP Address for Operation with a PC.....	337

2.2.3	STVI Ethernet Port .....	338
2.2.3.1	Setting SMRT IP Address for Operation with STVI .....	338
2.2.4	IN - IEC61850 Ethernet Port .....	338
2.2.4.1	Setting SMRT IP Address for Networks or IEC 61850 Operations.....	339
3.0	<b>Current Sources</b> .....	339
3.1	<b>Parallel Operation</b> .....	339
3.1.1	Manual Test Screen - Single Phase Up To180 Ampere .....	340
3.2	Currents in Series Operation .....	341
4.0	<b>Voltage Sources</b> .....	343
4.1	Outputs Summed Together .....	343
4.2	3Ø, 3-Wire, Open-Delta and T-Connection .....	344
4.2.1	Balanced Open Delta .....	344
4.2.2	T-Connection.....	344
	<b>Addendum D SMRT36D</b> .....	346
	<b>Safety Precautions</b> .....	346
1.0	<b>Operation</b> .....	347
1.1	<b>General Description</b> .....	347
1.1.1	Top Panel.....	347
1.1.2	Front Panel.....	349
1.2	<b>Input Power</b> .....	350
1.2.1.	Input Power Cord .....	350
1.3	<b>Voltage Current Generator (VIGEN) Module</b> .....	351
1.3.1.	Convertible Voltage/Current Amplifier .....	351
1.3.2.	Current Amplifier .....	352
1.4	<b>Binary Inputs and Outputs</b> .....	352
1.4.1	Binary Inputs .....	353
1.4.1.1	Start, Stop, and Monitor Gates .....	353
1.4.1.1.1	Dry Contacts Open .....	353
1.4.1.1.2	Dry Contacts Close .....	353
1.4.1.1.3	Application or Removal of AC or DC voltage .....	353
1.4.2	Binary Outputs.....	354
1.5	<b>Battery Simulator</b> .....	354
2.0	<b>SETUP</b> .....	354
2.1	Unpack System.....	354
2.2	<b>Communication Ports</b> .....	355
2.2.1	USB 2.0 Interface.....	355
2.2.2	PC/IN Ethernet Port .....	356
2.2.2.1	Setting SMRT IP Address for Operation with a PC .....	356
2.2.3	ISOLATED Ethernet Port .....	357
2.2.4	IEC61850 / OUT Ethernet Port .....	357
2.2.4.1	Setting SMRT IP Address for Networks or IEC 61850 Operations.....	358
3.0	<b>Current Sources</b> .....	358
3.1	Parallel Operation .....	358
3.1.1	Manual Test Screen - Single Phase Up To180 Ampere .....	359
3.2	Currents in Series Operation .....	360
4.0	<b>Voltage Sources</b> .....	362
4.1	Outputs Summed Together .....	362
4.2	3Ø, 3-Wire, Open-Delta and T-Connection .....	363
4.2.1	Balanced Open Delta .....	363
4.2.2	T-Connection.....	364
4.3	3Ø, 4-Wire, Y-Connection.....	364
	<b>Addendum E SMRT43D/46D</b> .....	366
	<b>Safety Precautions</b> .....	366
1.0	<b>Operation</b> .....	367
1.1	<b>General Description</b> .....	367

1.1.1	Top Panel.....	367
1.1.2	Front Panel.....	369
1.2	<b>Input Power</b> .....	370
1.2.1.	Input Power Cord.....	370
1.3	<b>Voltage Current Generator (VIGEN) Module</b> .....	371
1.3.1.	Convertible Voltage/Current Amplifier.....	371
1.3.2.	Current Amplifier.....	372
1.4	<b>Binary Inputs and Outputs</b> .....	373
1.4.1	Binary Inputs.....	373
1.4.1.1	Start, Stop, and Monitor Gates.....	373
1.4.1.1.1	Dry Contacts Open.....	374
1.4.1.1.2	Dry Contacts Close.....	374
1.4.1.1.3	Application or Removal of AC or DC voltage.....	374
1.4.2	Binary Outputs.....	374
1.5	<b>AC/DC AUX Output (V4)</b> .....	374
2.0	<b>SETUP</b> .....	375
2.1	Unpack System.....	375
2.2	<b>Communication Ports</b> .....	375
2.2.1	USB 2.0 Interface.....	376
2.2.2	PC/IN Ethernet Port.....	377
2.2.2.1	Setting SMRT IP Address for Operation with a PC.....	377
2.2.3	ISOLATED Ethernet Port.....	378
2.2.4	IEC61850 / OUT Ethernet Port.....	378
2.2.4.1	Setting SMRT IP Address for Networks or IEC 61850 Operations.....	378
3.0	<b>Current Sources</b> .....	378
3.1	Parallel Operation.....	378
3.1.1	Manual Test Screen - Single Phase Up To180 Ampere.....	379
3.2	Currents in Series Operation.....	381
4.0	<b>Voltage Sources</b> .....	382
4.1	Outputs Summed Together.....	382
4.2	3Ø, 3-Wire, Open-Delta and T-Connection.....	383
4.2.1	Balanced Open Delta.....	383
4.2.2	T-Connection.....	384
4.3	3Ø, 4-Wire, Y-Connection.....	384
	<b>Addendum F SMRT410</b> .....	386
1.0	<b>Operation</b> .....	387
1.1	<b>General Description</b> .....	387
1.1.1	Top Panel.....	387
1.1.2	Front Panel.....	388
1.2	<b>Input Power</b> .....	389
1.2.1.	Input Power Cord.....	390
1.3	<b>Voltage Current Generator (VIGEN) and Double-Current (DIGEN) Modules</b> .....	390
1.3.1.	Convertible Voltage/Current Amplifier.....	390
1.3.2.	Current Amplifier.....	391
1.4	<b>Binary Inputs and Outputs</b> .....	392
1.4.1	Binary Inputs.....	392
1.4.1.1	Start, Stop, and Monitor Gates.....	392
1.4.1.1.1	Dry Contacts Open.....	393
1.4.1.1.2	Dry Contacts Close.....	393
1.4.1.1.3	Application or Removal of AC or DC voltage.....	393
1.4.2	Binary Outputs.....	393
1.5	<b>Battery Simulator</b> .....	393
2.0	<b>SETUP</b> .....	394
2.1	Unpack System.....	394
2.2	<b>Communication Ports</b> .....	394

2.2.1	USB 2.0 Interface.....	395
2.2.2	PC/OUT Ethernet Port .....	395
2.2.2.1	Setting SMRT IP Address for Operation with a PC .....	395
2.2.3	STVI Ethernet Port.....	396
2.2.3.1	Setting SMRT IP Address for Operation with STVI .....	396
2.2.4	IN - IEC61850 Ethernet Port .....	396
2.2.4.1	Setting SMRT IP Address for Networks or IEC 61850 Operations.....	397
3.0	<b>Current Sources</b> .....	397
3.1	<b>Parallel Operation</b> .....	397
3.1.1	Manual Test Screen - Single Phase Up To180 Ampere .....	398
3.2	Currents in Series Operation .....	399
4.0	<b>Voltage Sources</b> .....	401
4.1	<b>Outputs Summed Together</b> .....	401
4.2	<b>3Ø, 3-Wire, Open-Delta and T-Connection</b> .....	403
4.2.1	Balanced Open Delta .....	403
4.2.2	T-Connection.....	403
4.3	<b>3Ø, 4-Wire, Y-Connection</b> .....	404
<b>Addendum G SMRT410D</b> .....		405
1.0	<b>Operation</b> .....	406
1.1	<b>General Description</b> .....	406
1.1.1	Top Panel.....	406
1.1.2	Front Panel.....	408
1.2	<b>Input Power</b> .....	409
1.2.1.	Input Power Cord .....	409
1.3	<b>Voltage Current Generator (VIGEN) and Double-Current (DIGEN) Modules</b> .....	410
1.3.1.	Convertible Voltage/Current Amplifier .....	410
1.3.2.	Current Amplifier .....	411
1.4	<b>Binary Inputs and Outputs</b> .....	412
1.4.1	Binary Inputs .....	412
1.4.1.1	Start, Stop, and Monitor Gates .....	412
1.4.1.1.1	Dry Contacts Open .....	413
1.4.1.1.2	Dry Contacts Close .....	413
1.4.1.1.3	Application or Removal of AC or DC voltage .....	413
1.4.2	Binary Outputs.....	413
1.5	<b>Battery Simulator</b> .....	414
2.0	<b>SETUP</b> .....	414
2.1	Unpack System.....	414
2.2	<b>Communication Ports</b> .....	414
2.2.1	USB 2.0 Interface Port .....	415
2.2.2	PC/IN Ethernet Port .....	416
2.2.2.1	Setting SMRT IP Address for Operation with a PC .....	416
2.2.3	ISOLATED Ethernet Port .....	417
2.2.4	IEC61850 / OUT Ethernet Port .....	417
2.2.4.1	Setting SMRT IP Address for Networks or IEC 61850 Operations.....	417
3.0	<b>Current Sources</b> .....	417
3.1	Parallel Operation .....	417
3.1.1	Manual Test Screen - Single Phase Up To 360 Amperes .....	418
3.2	Currents in Series Operation .....	420
4.0	<b>Voltage Sources</b> .....	421
4.1	Outputs Summed Together .....	421
4.2	<b>3Ø, 3-Wire, Open-Delta and T-Connection</b> .....	422
4.2.1	Balanced Open Delta .....	423
4.2.2	T-Connection.....	423
4.3	<b>3Ø, 4-Wire, Y-Connection</b> .....	423

## 1.0 Introduction

This user manual is organized into sections. The first section is related to the operation of the software designed to control various models of Megger relay test systems such as the SMRT Family of units. The software may be run on a typical PC, or the “On-Board” version on various models of the SMRT-D units such as the SMRT46D or comes imbedded on the STVI handheld controller. After the description of the software will be descriptions of the hardware systems including the various models of SMRT units.

The **STVI** handheld controller is a user-friendly interface to control the **Megger SMRT** relay test sets and other Megger equipment like the MRCT, MVCT and legacy MPRT units. This section of the manual contains the information that you will need to set up and use your STVI with the SMRT Relay Test Systems. This section also includes a description of RTMS. The STVI uses the embedded version of RTMS. There is a PC version of the same software, as well as the On-Board version of RTMS that runs on the SMRT-D units.

There are two versions of the STVI handheld controller.

- STVI-1 (discontinued)      Used with SMRT33/43, SMRT36/46, and SMRT410
- STVI-10                      Used with SMRT33/43, SMRT36/46, SMRT410
- STVI-2 (discontinued)      Used with SMRT1.
- STVI-20                      Used with SMRT1
- STVI-2 (discontinued) and STVI-20 is a STVI with an external Power Over Ethernet power supply and Ethernet interface unit.
- Note that the SMRT1D, SMRT36D, SMRT43D, SMRT46D and SMRT410D units have the STVI touch screen, control knob, and software built into the units.

### 1.1 Smart Touch View Interface

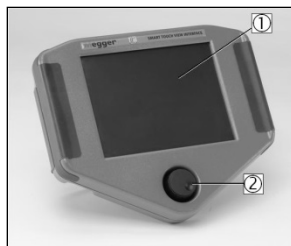

Figure 1a STVI-1 – Handheld Controller

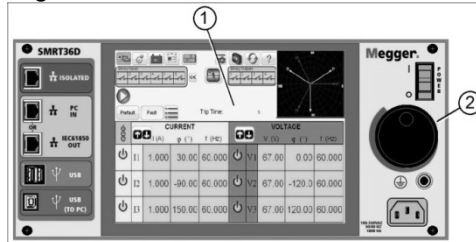

Figure 1b SMRT43D/46D/410D Series.

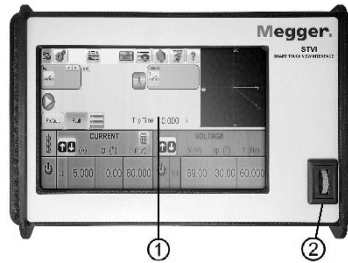

Figure 1c New STVI-10 Handheld Controller

1. **TFT LCD Color Display** ① – this 8.5-inch touch panel display provides high resolution and features Wide Viewing Angle Technology with high luminance for reading in direct sunlight.
2. **Control Knob** ② – this knob will adjust values once the box location of the value to be changed is selected.



Figure 2 Discontinued STVI-1 Rear-View

3. **Built-in Foldout Stand** ③ – the STVI may be operated as a handheld controller, or foldout the built-in stand and use a desktop controller.
4. **STVI Ethernet Port** ④ – this Ethernet port is a 100BaseTX PoE (Power over Ethernet) port and is the SMRT connection port.
5. **STVI USB Interface** ⑤ – the USB 2.0 Interface requires a Type A connector and is primarily used as a communication and control port. A USB cable may not be provided with the test set or in the optional accessories. For control of the SMRT units, an Ethernet cable is provided since the STVI gets its power over the Ethernet. Even though the STVI has a built-in virtual keyboard, the user can use a USB keyboard with the STVI, as well as a mouse (including Logitech wireless mouse), a keyboard and/or mouse are not included with the accessories. The USB port is also used to update the firmware in the SMRT as well as update RTMS in the STVI using a USB memory stick. It may also be used to download test

results from the STVI for download onto another PC with PowerDB software for storage or printing.

## 1.2 Terminology

The acronyms, terms, and definitions used throughout this manual are described below:

### 1.2.1 Acronyms

<b>AC</b>	Alternating Current
<b>CW</b>	Clockwise (rotation)
<b>CCW</b>	Counterclockwise (rotation)
<b>DC</b>	Direct Current
<b>GPS</b>	Global Position System
<b>GUI</b>	Graphical User Interface
<b>Hz</b>	Hertz
<b>I</b>	Current
<b>ID</b>	Identification
<b>I/O</b>	Input / Output
<b>IRIG-B</b>	Inter-Range Instrumentation Group Timecode B
<b>kHz</b>	Kilo Hertz
<b>LCD</b>	Liquid Crystal Display
<b>LED</b>	Light Emitting Diode
<b>MAG</b>	Magnitude
<b>MTA</b>	Maximum Torque Angle
<b>PC</b>	Personal Computer
<b>ROM</b>	Read-Only Memory
<b>RTS</b>	Relay Test System
<b>USB</b>	Universal Serial Bus
<b>VAC</b>	Volts Alternating Current
<b>VDC</b>	Volts Direct Current
<b>V</b>	Volts
<b>VIGEN</b>	Voltage / Current Generator Module
<b>V RMS</b>	Volts Root Mean Square
<b>UUT</b>	Unit Under Test
<b>W</b>	Watts

### 1.2.2 Glossary of Terms

The STVI display screens prompt the user to select, or set, various values. The values vary depending on the relay under test, and the relay setting screen. Many of the terms used are similar in nature and mean the same thing regardless of the type of relay. For example, the term Time Dial is commonly used to define the time dial setting on the relay under test. The Time Dial could be on an overcurrent relay, or just as easily be on a under voltage relay. Unfortunately, some of the terms described here may apply to different types of relays in different ways, and thus may not cover every relay made. However, it is hoped that this glossary will help the user to understand every setting value on every relay setting screen.

#### 1.2.2.1 Pickup (Tap)

A numerical value associated with a tap setting on the relay. **Pickup** or Tap is normally associated with a value of current, voltage, phase angle, frequency, W or Ohms. It is used to define a setting value, pick up value, or minimum operating point, of the relay under test.

#### 1.2.2.2 TDM (Time Dial Multiple)

A numerical value normally associated with a TIME CURVE or defines the use of a specific time curve from a family of curves. Used when conducting a timing test. The TIME DIAL number also may be used in a Time-Curve algorithm in calculating the theoretical operating time of the relay under test.

#### 1.2.2.3 **Inst.** (Instantaneous Tap)

A numerical value associated with a tap setting on the instantaneous element of the relay. Normally associated with a value of current or voltage, it is used to define a pickup value, or minimum operating point, of the instantaneous element of the relay under test.

#### 1.2.2.4 **Reset Seconds**

It is a numerical value of time, normally associated with electromechanical relays. This is the amount of time required for the operating disk to reset. If multiple timing tests are conducted on a relay, the test system will wait for the Reset Seconds value prior to applying the next timing test. Numerical relays also can have programmable reset times to coordinate with electromechanical relays.

 Note, if the Reset Seconds is set too short, and the disk does not completely reset, then timing error will be introduced to the test.

#### 1.2.2.5 **Time Delay**

It is a numerical value of time, normally associated with the minimum operating time of electromechanical instantaneous relays. This is the minimum amount of time delay associated with the closing of the instantaneous trip contacts. When a value is entered, a line will be drawn associated with the time entered in the trip characteristic display. If one of the test points selected by the user is for testing the instantaneous operation, it will be plotted with the other time delay trip points.

 Note that numerical relays also can have programmable Time Delay settings associated with instantaneous operation.

#### 1.2.2.6 **Test Multiple**

A numerical value normally associated with conducting timing tests. Multiples are normally expressed in terms of whole numbers like 2, 3, 4, etc., times the Relay Pickup, or Tap, value of the relay under test. Fractions of test multiples may also be entered, and the appropriate test values and theoretical trip times will automatically be calculated. If no **Reset Seconds** (see 1.2.2.4) value is entered, then only one timing test point will be conducted when pressing the appropriate Blue Run Test button in RTMS. If a Reset Seconds value is entered, after pressing the first blue Run Test button the test system will perform all the Test Multiples in sequence waiting for the Reset Seconds between applications of the entered Test Multiples.

#### 1.2.2.7 **Reach or Diameter**

A numerical value expressed in Ohms. This value is used to determine the “distance,” in Ohms, that the relay under test “sees” either into a line section, or into a generator.

#### 1.2.2.8 **Angle** (Torque)

A numerical value expressed in degrees. A value used in impedance relays to define the “maximum torque angle” or “line angle” setting of the relay under test (sometimes abbreviated as **Ang.**).

### 1.2.2.9 **Expected Trip Time**

A numerical value which expresses the operating time of the relay under test, normally used to specify a definite operating time for a given fault value in the testing of multi-zone distance relays.

### 1.2.2.10 **Winding (1,2,3,4) Tap**

A numerical value associated with the Winding Number i.e., 1, 2, 3, 4, etc., of a transformer differential relay, used to define the tap setting value and test for each winding.

### 1.2.2.11 **% Slope**

A numerical value which establishes the operating characteristic of a differential relay. The operating characteristic of the differential relay is a line, with a slope defined by the ratio of the operating and restraint values.

### 1.2.2.12 **% Harmonic**

A numerical value which establishes the percent of harmonic restraint for a harmonic restrained transformer differential relay. This value will be used to determine Pass/Fail during the Harmonic Restraint test.

### 1.2.2.13 **% Prefault Seconds**

It is a numerical value of time, normally associated with relays which require prefault values prior to applying the fault values. This is the amount of time required for the operating disk to set. to a "normal" operating state, or a microprocessor-based relay to be properly polarized prior to applying the fault state. A couple of examples would be an electromechanical voltage relay, or a numerical distance relay. If multiple tests are conducted on a relay, the test system will apply the Prefault Seconds value prior to applying the next test value.

 Note, if the Prefault Seconds is set too short, and the relay may not completely come to rest (if electromechanical), or be properly polarized, then an error will be introduced to the test.

## 1.3 **Power Over Ethernet Input Power**

The STVI gets Power Over Ethernet (PoE) of 48 VDC at 0.5 A from the SMRT33/43/36/46/410. The SMRT1 units do not provide the 48 VDC required by the STVI. The SMRT1, when ordered with the STVI-20, comes with a PoE power supply. The PoE input power supply voltage may be from 100 to 240 VAC, 50/60 Hz.



### **CAUTION:**

**NOTE: The PoE power supply DC voltage is ON when the power supply is connected to a power source. Connect the Ethernet cable to the Data & Power Out port of the PoE power supply to the STVI Ethernet port prior to connecting to a power source.**

### 1.3.1. PoE Power Supply-Input Power Cord

When the STVI is ordered with the SMRT1 the power cord that comes with the PoE Power Supply is based upon the power cord selection in the SMRT1 style number. Depending on the country, the power supply can come with a NEMA 5-15 male connector, a CEE 7/7 Schuko two prong connector,

come with International Color-Coded pig-tail wires (light blue, brown and green with yellow stripe) with the insulation jacket stripped ready for installation of the appropriate male connector, or the UK power cord.

### North American power cord (part number 620000)

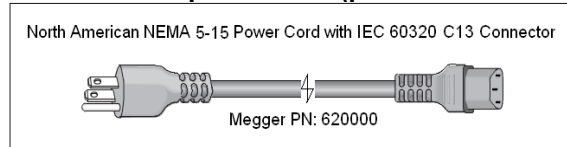

### Continental Europe power cord (part number 50425)

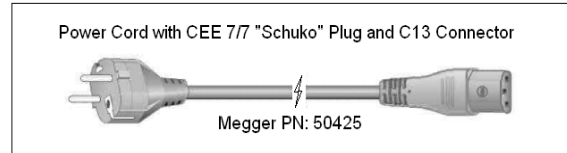

The **International Color Code power cord (part number 15065)** is ready for wiring to the appropriate plug (depending on country). The following colors apply, Brown = Line, Blue = Neutral and Green/Yellow = Ground.

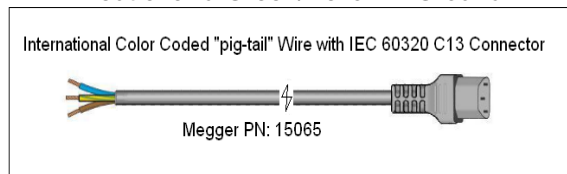

### UK power cord (part number 90002-989)

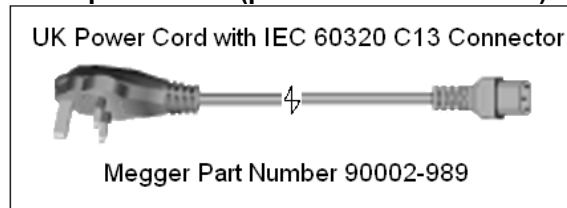

## 2.0 SETUP

### 2.1 Unpack System

Unpack the unit and check for evidence of any shipping damage. If there is any visual damage, immediately notify the freight carrier to make a damage claim and notify Megger of the damage.

#### 2.1.1 Initial Start Up

1. With the Ethernet cable supplied with the unit connect the STVI Ethernet Port on the SMRT33/43/36/46/410 unit to the Ethernet port on the top of the Smart Touch View Interface

(STVI). For operation with the SMRT1 units, connect the **Data & Power Out** port of the PoE power supply to the STVI Ethernet port, and the PoE power supply **Data In** port to the SMRT1 PC/IN port.

2. Before connecting power to the unit, make sure the Unit POWER ON/OFF Switch is in the OFF position (O). Plug the unit line cord into an appropriate power source and turn the POWER ON/OFF Switch to ON (I). As the SMRT unit goes through its power up sequence, in about a minute the STVI power up screen will appear, then the manual start-up screen will appear. For the SMRT1 units, connect the PoE power supply power cord to an appropriate power source.

## 2.2 Communication Ports

There are two types of communication ports on the STVI, one Ethernet, and two USB ports.

### 2.2.1 Ethernet Port

There is one Ethernet port on the STVI for connecting to the SMRT units. On the SMRT33/43/36/46/410 units the port label is STVI. For the SMRT1, it connects to the PoE power supply unit, and the PoE unit connect to the PC/IN port on the SMRT1.

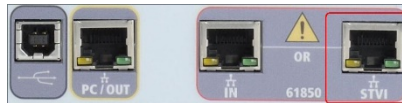



Figure 3 STVI port on SMRT units

### 2.2.2 USB 2.0 Interface

There are two USB 2.0 Interface ports on the STVI unit. These ports can be used for upgrading firmware to the SMRT unit or upgrading RTMS on the STVI using a USB Memory Stick. They may also be used in conjunction with a USB mouse for ease of manual control, even a USB wireless mouse can be used with the STVI.

 Regarding control of the SMRT with the USB port, see section 2.2.1 in Addendums (SMRT33/43/36/46, SMRT36D, SMRT46D, SMRT410, SMRT410D).

Ethernet Port is a 100BaseTX port and is the primary PC connection port. This port supports MDI/MDI-X auto crossover configuration, which means both standard and “crossover” Ethernet cables may be used. The SMRT units come with a standard Ethernet cable. This port may also be used to interconnect multiple SMRT units together for synchronous multi-phase operation.

## 2.3 RTMS and STVI Hand-Held Controller

This section of the manual includes a description of RTMS, which runs on the STVI Hand-Held Controller, which is the same version of software in the SMRT- D Series of units, or that runs on a PC. RTMS is the manual control and user interface for the unit. All manual entries will be made through the touch screen of the STVI unless the unit is connected to a personal computer.

During the power up sequence, the test system automatically does self-test to insure everything is operating properly. Once the system has completed self-checks the Introduction Screen will appear, see the following figure (older model STVI Hand-Held Controllers will have a different Introduction Screen).



Figure 4 RTMS Introduction Screen

Shortly afterward, the screen will change to the manual test screen. Depending on how many channels are available RTMS will provide the appropriate number. For example, in the following figure is the power up manual test screen for a 3 channel SMRT33/36/43/46 unit.

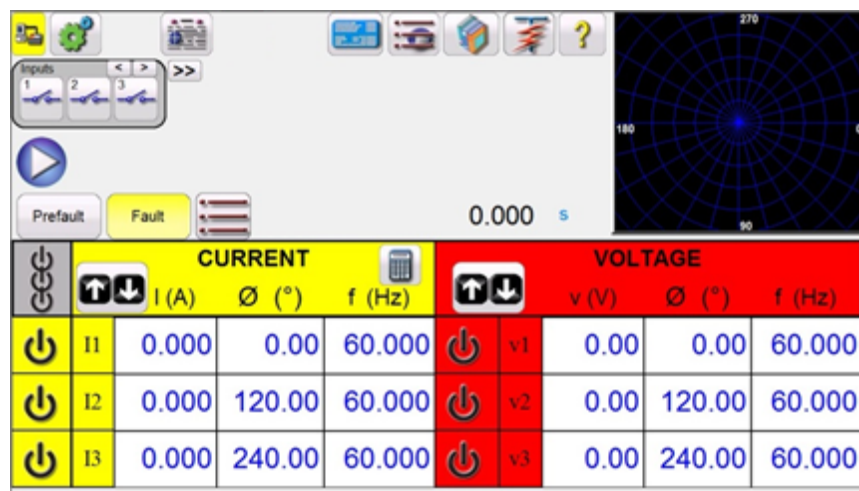



Figure 5 Manual Test Screen (PC version)

In the upper left-hand corner, click on the unit connection button  and the PC or the STVI hand-held controller will auto detect the unit connected and automatically set the IP address through the Ethernet port. RTMS will auto-detect the unit (does not require the user to input an IP address). Once the STVI hand-held controller detects and connects to the unit, the icon connection will turn green. The SMRT-D units will not require any action by the user. If using the PC version, it too can auto-detect the unit connected to the PC. On the PC version, the unit might not auto detect due to firewall settings. In this case the firewall can be turned off or you can enter the IP address directly using the PowerDB instrument configuration screen by clicking on the Instrument Setup icon on the PowerDB

tool bar . From the Instrument Configuration Screen, shown in the following figure, click off the check mark in the Auto Discover Unit box.

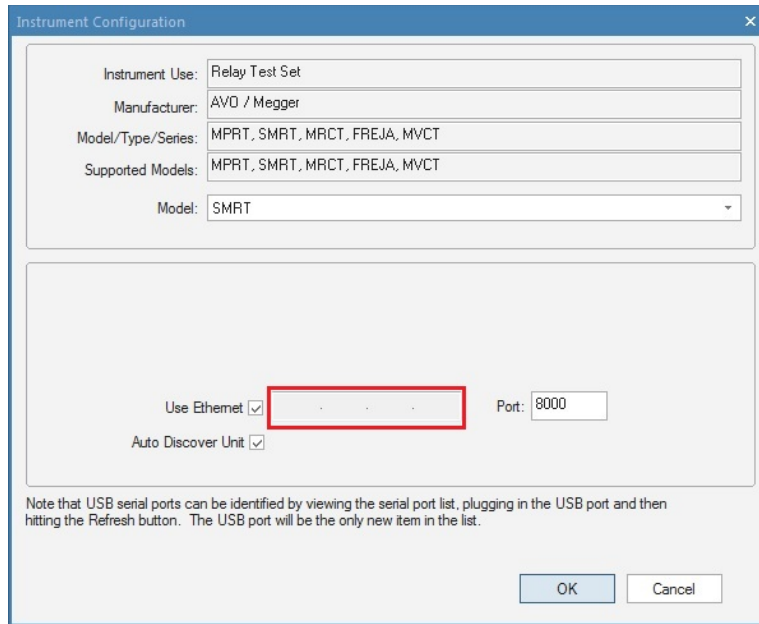



Figure 6 PowerDB Instrument Setup Screen

With the Auto Discover Unit box checked RTMS should find the unit. If not, the IP address can be entered in the box highlighted in the figure above. Also, note that the IP address is also printed on the unit nameplate sticker. If the unit is on a network with a DHCP server, the user must use the Auto Discovery mode.

### 2.3.1 Configuration

Pressing the Configuration button  will allow the user to configure the SMRT hardware and RTMS for items such as language and phase angle rotation. Pressing this button will display the Configuration screen.

 Note: The following button descriptions vary depending on hardware configuration, and if using an STVI hand-held controller, or the PC version of RTMS. See the following Configuration Screen example.

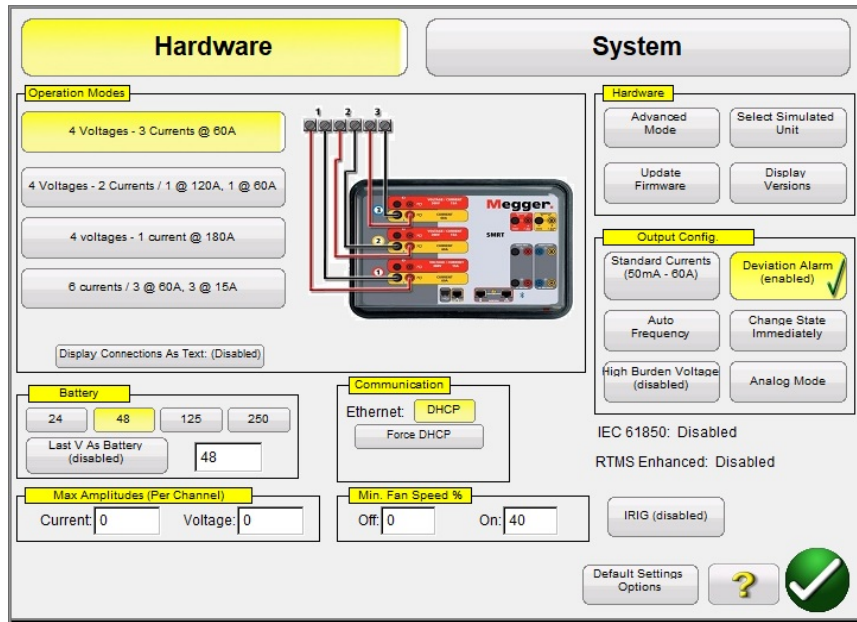



Figure 7 Example Configuration Screen for SMRT46  
 Note: the picture will change depending on type of unit detected

Under Hardware Configuration, the user can select Operation Modes, Battery Simulator, Hardware, Output Configuration, Communications, set Max Amplitudes, Enable IRIG, and adjust the Fan Speed. In the System Configuration the user can select Primary Settings to be displayed on the test screens, select Rogowski outputs from the current channels, set Low Level outputs from the voltage channels, set how Phase Angles are displayed, set General Settings, Auto-Save work, and enter a Header bit map to personalize test reports. The following are descriptions of both Hardware and System settings.

### 2.3.1.1 Operation Modes

The user can select the output configuration. The connection picture will change with the selection indicating to the user how to connect the outputs. With the selection, the STVI display will also change in combination with the selected outputs. For example, if a user needs more than 60 A, the 4 Voltages – 1 Current @ 180 A option can be selected and will allow the user to enter the value directly in the manual test screen. The display will change to a single current channel and the value entered will automatically be distributed across all available current generators.

### 2.3.1.2 Battery Simulator

For SMRT units with the 'P' System Board Option includes the battery simulator, the user can either select one of the common battery voltages levels or enter the desired voltage level in the window provided. Note that the SMRT-D units have the battery simulator built into the unit (not optional). Upon returning to the test screen the voltage value will be displayed in the Battery Simulator button . Press this button to turn the output on/off. The button changes color with the change in output. Note: SMRT1 or SMRT33 units do not have a Battery Simulator.

#### 2.3.1.2.1 Last VIGEN is Battery

Selecting this button will convert the last voltage channel (normally #3) to a battery simulator. This is especially useful if the unit does not have the system board with a battery simulator ('P' option).

### 2.3.1.3 Display Versions (Information Screen)

This button is found in the Hardware Section. Pressing this button will display serial numbers, firmware, and driver versions, and build dates.



This information is useful when calling Megger for service or technical support related issues.

#### 2.3.1.3.1 Command button

This button will open the Mini RTS Command Terminal. This window is used to send RTS commands to the unit, such as **qc**; (query the configuration of the unit). In addition, it is used to enable feature upgrades to the unit, such as RTMS Enhanced Hardware Upgrade kit PN: 84973, or IEC 61850 GOOSE Hardware Upgrade kit PN: 83646, or IEC 61850-9-2LE Sampled Values Hardware upgrade kit PN: 88695.

#### 2.3.1.4 Update Firmware

This button is found in the Hardware Section. This button is used to update the SMRT firmware and/or the On-Board version of RTMS.

#### 2.3.1.5 Auto Frequency

This button is found in the Output Config. Section. In the default Auto Frequency position, the SMRT units will measure and determine the input frequency and automatically set the default output frequency to the line frequency. Other choices are 50 Hz, 60 Hz, Line Sync, 25 Hz, 16.667 Hz, and Custom, so that the output frequency can be something other than the input line frequency. Selecting Line Sync the output phase angles are in a direct relationship with the positive going zero crossing of the input line frequency. Thus, multiple SMRT units can be synchronized together without needing a physical interconnection.



Note: the phase angle accuracy may vary as much as 2 degrees when in Line Sync Mode.

#### 2.3.1.6 Deviation Alarm

This button is found in the Output Config. Section. This button turns the deviation alarm on and off. When the deviation alarm is on, if the output waveform has excessive deviation, the alarm will sound.

#### 2.3.1.7 Change State Immediately/Change on Zero Cross/Change on Master Zero

This button is found in the Output Config. Section. Unit defaults to the Immediate Mode where amplitudes, phase angles and frequency changes take place immediately upon command. The Zero Cross Mode is used to force all amplitude, phase angle or frequency changes to take place at the positive going zero crossing of the sine wave (normally used when testing frequency relays). Change to Master Zero – All phases will start on the Zero crossing of the Master Clock. All phases will change at the same time. This is useful when testing per IEC 60255.

#### 2.3.1.8 Standard Currents button

This button is found in the Output Config. Section. There are two modes of operation for the current amplifier, Standard Currents, and High Burden/Current Mode. The default Standard Currents mode, the high compliance voltage of 50 V is available down to 1 A. When the output current drops below 1 A the current amplifier changes ranges automatically and the compliance voltage drops to 15 V. If a high compliance voltage of 50 V is required for test currents below 1 A, press the Current Amplifier

Mode button. The Current Amplifier Mode provides high compliance voltage on the output current channels for test currents below 1 A.

### 2.3.1.9 High Burden Voltage

This button is found in the Output Config. Section. Pressing the High Burden Voltage button enables the voltage amplifier to output up to 1 A at 300 V.

### 2.3.1.10 Analog Mode

This button is found in the Output Config. Section. The default position is Analog Mode, where the output terminals provide analog values based upon the settings. Pressing the Analog Mode button will change to SV Mode. If the unit has the Sampled Values hardware option, when the SV Mode is selected, the SMRT can provide three IEC 61850 9-2 LE SV data streams with 4 voltages and 4 currents on each stream. Sampled Values (SV) are used for transmitting digitized values of currents and voltages on ethernet frames using a publisher/subscriber mechanism from the Ethernet Out port.

### 2.3.1.11 Ethernet (DHCP) IP Address

The Communication section provides communication control for the test system. As mentioned at the beginning of section 2.2, RTMS will auto-detect the SMRT unit (the DHCP mode does not require the user to input an IP address). If the unit is on a network with a DHCP server, the user must use the Auto Discovery mode. Using RTMS on the STVI handheld controller, pressing the DHCP button will produce the IP Address Dialog box.

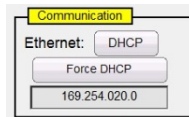



Figure 8 STVI Configuration Screen Ethernet IP Address Dialog Box

If using the PC version, it too can auto-discover the SMRT unit connected to the PC. On the PC version, the PC might not auto detect due to firewall or VPN settings. In this case the firewall can be turned off, or you can enter the IP address directly using the PowerDB instrument configuration

screen by clicking on the Instrument Setup icon on the PowerDB tool bar . Shown in the following figure is the PowerDB Instrument Configuration Screen. Click off the check mark in the Auto Discover Unit box. Here the user can enter the IP address directly into the box highlighted in red.

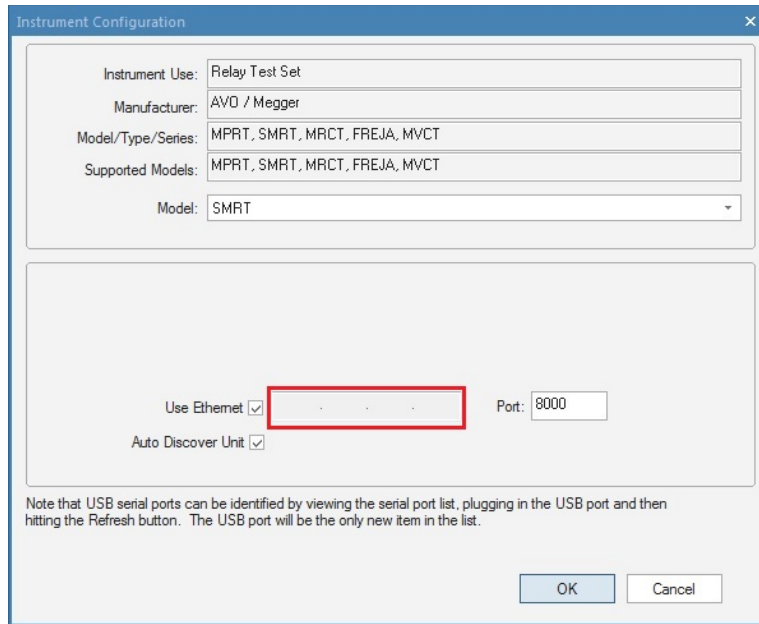

Figure 9 PowerDB Instrument Configuration Screen

### 2.3.1.12 Advanced Mode - Convertible V/I Selection for Multi-Phase Current Output

In the Hardware section of the Configuration Screen, click on the Advanced Mode button to access the number of voltage channels for conversion to current channels. Should you need more than 3, but less than 6 current channels, press this button to select how many voltage channels to convert. For example, if you need 4 current channels. Press the Advance button, set 1 in the **# of Convertible Channels** box provided in the Operations Modes window. Going back to the test screen Voltage Channel #1 will now be converted to a current channel.

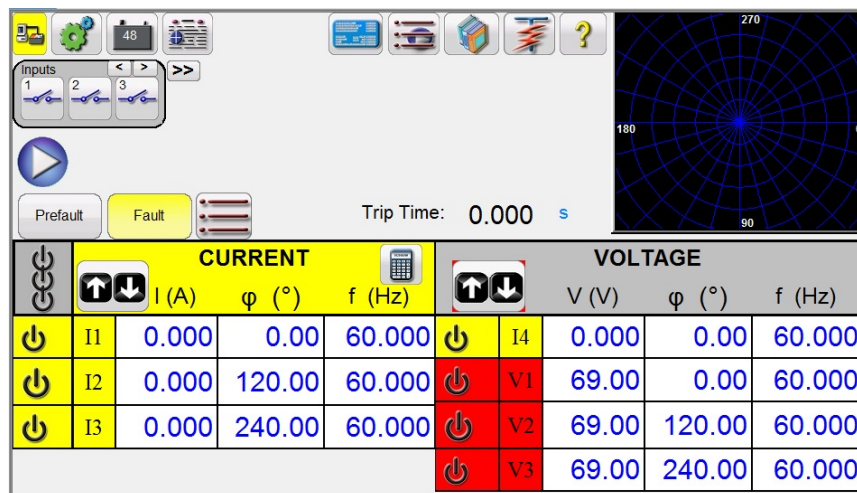

Figure 10 SMRT 46 Voltage channel converted to current channel.

Note that conversion of voltage channels starts with channel #1 and goes up. Therefore, selecting 2 convertible channels will result with voltage channels #1, and #2 being converted to current channels leaving voltage channel #3 as a voltage output.

### 2.3.1.13 ? Help Button

Press this button to access the built-in manual for help associated with the Configuration Screen.

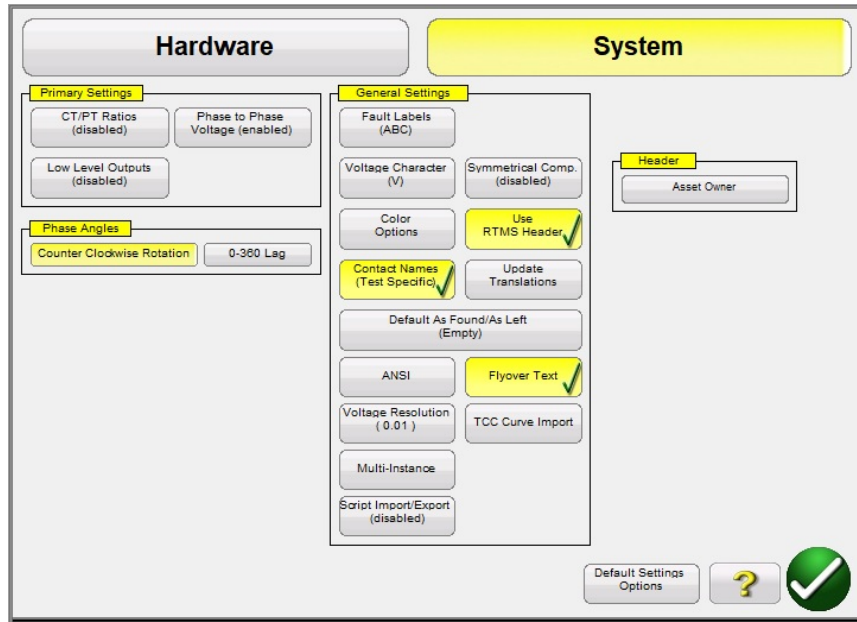

Figure 11 System Settings Screen

### 2.3.1.14 Phase Angles

The Phase Angles control section can be found in the System Settings of the Configuration screen. Select the desired phase angle display for the Phase Vector Screen. The phase angle designations can be set to 0 to 360 degrees Lead/Lag, or  $\pm 180$  degrees (positive angles are leading). The rotation can also be set to either counterclockwise or clockwise rotation. The factory default is 0-360° lagging. Press the Phase Angle select button, and the following screen will appear.

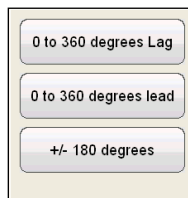

Figure 12 Phase Angle Selection Screen

See section 3.2 for more details on setting phase angle relationships.

### 2.3.1.15 Default Settings Options

Found in the System settings (next to the Help ? button); select this button to get access to the settings options of Save as Default, Restore Default, Restore Factory, Restore Factory Hot Environment default settings.



Figure 13 Default Settings Options

#### 2.3.1.15.1 Save as Default

Press this button and all the changes made to the Configuration Screen and most of the default values for all screens are now saved as the power up defaults.

#### 2.3.1.15.2 Restore Default

Pressing this button provides the ability to restore the original system power up defaults.

#### 2.3.1.15.3 Restore Factory

Pressing this button provides the ability to restore the original system factory power up defaults.

#### 2.3.1.15.4 Restore Factory Hot Environment

Pressing this button provides the ability to restore the original system factory power up defaults for units used in a hot environment (settings for fan speed).

#### 2.3.1.16 Max Amplitudes (Per Channel)

Found in the Hardware Settings of the Configuration screen; this button allows the user to set maximum outputs of current and voltage per channel from the test system. etc.

#### 2.3.1.17 Min. Fan Speed %

Found in the Hardware Settings of the Configuration screen; this button allows the user to adjust the fan speed. The default is set at 40%.

 Adjusting the fan speed will lower the fan noise. However, a lower fan speed will cause the internal temperature to rise faster and may cause a temporary shutdown of outputs while the unit cools down. Setting a higher speed may be required when operating in high ambient temperatures.

#### 2.3.1.18 IRIG

Found in the Hardware Settings of the Configuration screen; this button allows the user to enable the IRIG B decoding capability of Binary Input #1, normally used when performing End-to-End synchronized testing.

#### 2.3.1.19 Fault Labels (ABC)

Found in the General Settings of the System settings screen; this button allows the user to set labels for each phase as displayed in the test report such as ABC, RST, L1L2L3, etc.

#### 2.3.1.20 Language

Found in the General Settings of the System settings screen of RTMS on the STVI and SMRT-series units; this button allows the user to select the desired display language. The factory default is US English, but may be changed to International English, French, Canadian French, Spanish, German, Korean, Russian, Simplified Chinese, Polish, or Turkish.

#### 2.3.1.21 Color Options

Found in the General Settings of the System settings screen; press this button to adjust the colors of the vectors, backgrounds, lettering, etc.

#### 2.3.1.22 Symmetrical Components

Found in the General Settings of the System settings screen, pressing this button will change the vector display to show positive, negative and zero sequence vectors instead of amplitude and phase.

#### 2.3.1.24 Voltage Character

Found in the General Settings of the System settings screen; The character used to define and label the voltage output channels can be either V or U. Press this button to change the character. Be sure to press the Save as Default button to save the changes.

#### 2.3.1.25 Set Date and Time

Press this button to reset the Date and Time in the STVI hand-held controller, or the On-Board version in the SMRT-D series units. This information is critical for saving tests and test results in the unit internal file manager. The PC version uses the PC time and date.

#### 2.3.1.26 Logging

Select this button to log commands sent to the SMRT units from RTMS when using the STVI. This information can be useful to the Megger Technical Support Group when troubleshooting.

#### 2.3.1.27 Adjust Screen Brightness

The brightness is adjustable on the STVI hand-held controller as well as the STVI in the SMRT-D units. The display will always be visible since hardware limits the brightness from becoming too bright or too dark to be seen. Press this button and use the Control Knob to increase or decrease the brightness. For PC version use the PC screen control to adjust.

#### 2.3.1.28 CT/PT Ratios

The RTMS Configuration Screen includes the CT/PT Ratios setting button. This button is found in the Primary Settings section of the System Settings screen. Click or press on this button to open the following input selection screen.

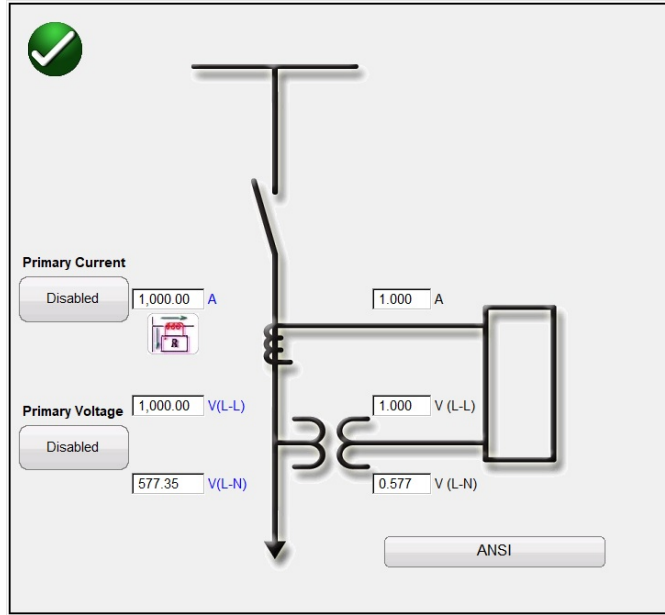



Figure 14 CT/PT Ratios Input Selection Screen

Select either ANSI or IEC graphics. Enter the appropriate Voltage and/or Current Primary and Secondary Values.

CT Earthing Position button 



In the default position, the simulated secondary current from test system will be in phase with the primary current, which flows from the bus bar into the protected line.



Pressing the button will change the direction, where the simulated secondary current from test system will be 180 degrees shifted compared to the same primary current used as reference.

Press or click on the Disabled buttons to Enable the value setting(s). Upon returning to the manual test screen Primary Values such as kV and kA will be displayed, see the following figure.

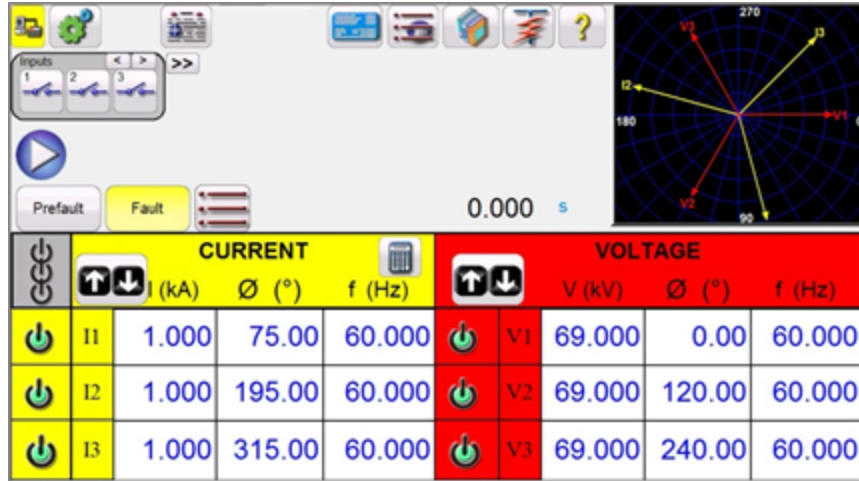

Figure 15 Primary Values kV and kA output test screen.

The above figure displays the primary values. This allows the user to evaluate relays using Primary Values displayed on the test screen, while applying the secondary values to the device under test based upon the CT/PT ratios.

### 2.3.1.29 Low Level Outputs

The Low-Level Outputs feature will only appear if the unit hardware includes the Low-Level Option.



#### Application Note:

The **Low (0-50 mA)**, **Rogowski** and **Low Voltage Modes** require VIGEN's with **hardware version 4.00 or higher**. To determine hardware version, go to the Configuration Screen and press the Display Versions button (see 2.3.1.3 Display Versions to find the hardware revision level).

The Low-Level Outputs button is found in the Primary Settings section of the Configuration/System Settings. The button defaults to (Disabled). Press this button to see the following setting screen.

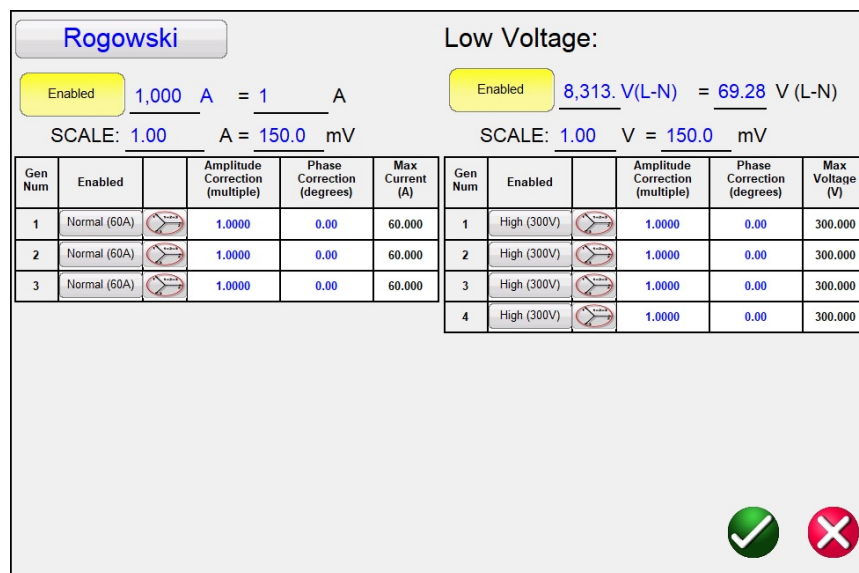

Figure 16 Low-Level Setting Screen

**!** **Application Note:** Note that the CT/PT Ratios can be set and enabled from the Low-Level setting screen. Therefore, should the relay have Rogowski coils or a voltage divider, and settings are in primary values, the ratios can be set and enabled from this screen.

#### 2.3.1.29.1 Low Output Current Generator 0-50 mA/Rogowski

The current generator, hardware version 4.00 or higher, can provide extremely low current outputs ranging from 0 to 50 mA full scale, or be enabled to provide a low voltage output simulating a Rogowski coil or voltage divider output. Pressing or clicking on the **Normal (60 A)** button will provide the following selection menu.

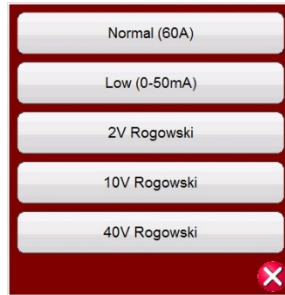



Figure 17 Current Generator Low Output Selection List

#### **Normal (60 A) Mode**

To return the current amplifier back to the normal operation, press or click on this button. Pressing the Balance  button will balance all the phases to the same value.

#### **Low (0-50 mA) Mode**

Pressing or clicking on this button will set the range of the current amplifier to the 50 mA range. With this range selected, the feedback loop will stay on to use test currents as low as 5 mA. This provides test capability for generator anti-motoring and Network relays, which can be set as low as 7.5 mA.

Pressing the Balance  button will balance all the phases to the same value.

#### **Rogowski Mode**

**!** **Application Note:**

For testing devices that require Low-Level voltage signals simulating Rogowski coils, voltage dividers, or other similar devices requires the Megger model MLLA low-level adapter interface, part number MLLA for three adapters, or V1013-611 for a single adapter. For testing relays like the ABB REF615 and Siemens 7SJ81, the low-level adapter provides the interface between the relay test set converted low-level output terminals and the low-level signal interface cables to the relay under test. Connect the MLLA modules to the individual VIGEN channels and then connect the appropriate interface cable for the device under test, see the following example.



Figure 18 MLLA Megger Low Level Adapter modules.

The Rogowski mode will change the current channel from a current source to a voltage source. This will allow the current channel to simulate a low-level voltage source from a Rogowski coil. There are three ranges for the Rogowski outputs, 2, 10 and 40 V. Pressing the Balance  button will balance all the phases to the same value.

**Setting Ratio of Secondary Current to millivolt Output**

Different Rogowski coils have different output levels. In the Rogowski Info screen the user sets the scale (or ratio) of the secondary current to mV output. This is used to adjust the ratio between the Rogowski coil mV outputs to an equivalent secondary current output. Enter the appropriate secondary current and associated mV output. Test values will be entered in secondary current values, with the appropriate mV applied to the relay under test. After entering the ratio of the secondary current to the mV output the user needs to enter the Amplitude and Phase Correction Factors.

**Amplitude and Phase Correction Factors**

In the Rogowski Screen the individual amplitude and phase corrections can also be set.

Rogowski:  
SCALE: 1.00 A = 150.0 mV





Gen Num	Enabled		Amplitude Correction (multiple)	Phase Correction (degrees)	Max Current (A)
1	2V Rogowski		1.0000	0.00	13.333
2	2V Rogowski		1.0000	0.00	13.333
3	2V Rogowski		1.0000	0.00	13.333

Figure 19 Rogowski Amplitude and Phase Correction Factors

Different relays have different Rogowski amplitude and phase correction settings. Check your relay settings and enter the appropriate values in the windows provided. Pressing the Balance  button will balance all the phases to the same value. Press or click on the green check mark to return to the Configuration screen, then press or click on the green check mark to return to the Main Test screen.

2.3.1.29.2 Low Voltage

**Low Voltage Mode**

The Low Voltage Mode will change the voltage channel to an mV source. This will allow the voltage channel to simulate a low-level voltage source such as a Rogowski or a voltage divider. Press the **High (300 V)** button to select the **Low (2 V)**, see figure below.

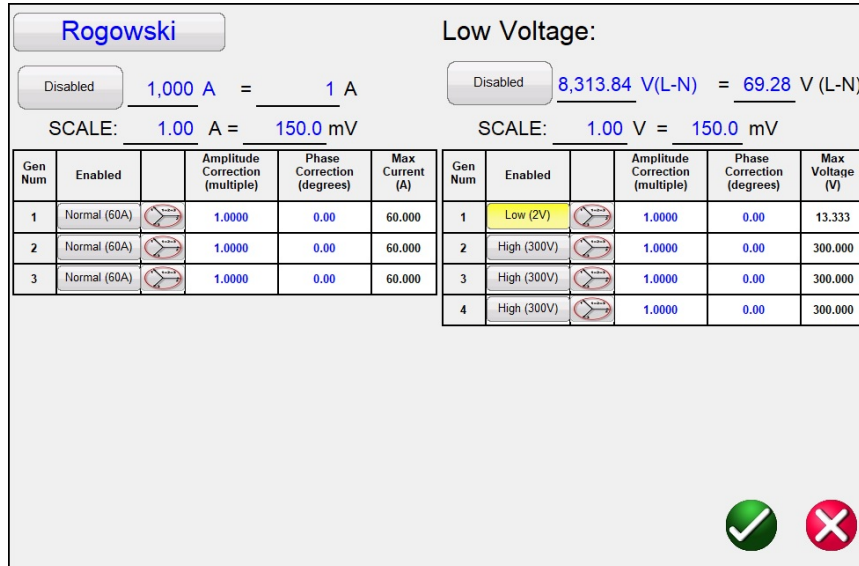



Figure 20 Selecting the 2 V range for the Low Voltage Output

**Setting Ratio of Secondary Voltage to millivolt Output**

Different Rogowski coils have different output levels. In the Low Voltage screen the user sets the scale (or ratio) of the secondary voltage to mV output. This is used to adjust the ratio between the Rogowski coil mV outputs to an equivalent secondary voltage output. Enter the appropriate secondary voltage and associated mV output. Pressing the Balance  button will balance all the phases to the same value. After entering the ratio of the secondary voltage to the mV output the user needs to enter the Amplitude and Phase Correction Factors.

**Amplitude and Phase Correction Factors**

In the Low Voltage Screen the individual amplitude and phase corrections can also be set.

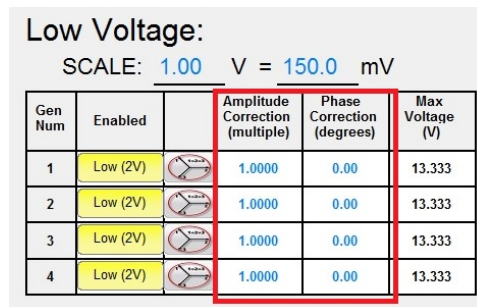

Figure 21 Low Voltage Amplitude and Phase Correction Factors

Different relays have different amplitude and phase correction settings. Check your relay settings and enter the appropriate values in the windows provided. Press or click on the green check mark to return to the Configuration screen, then press or click on the green check mark to return to the Main Test screen.

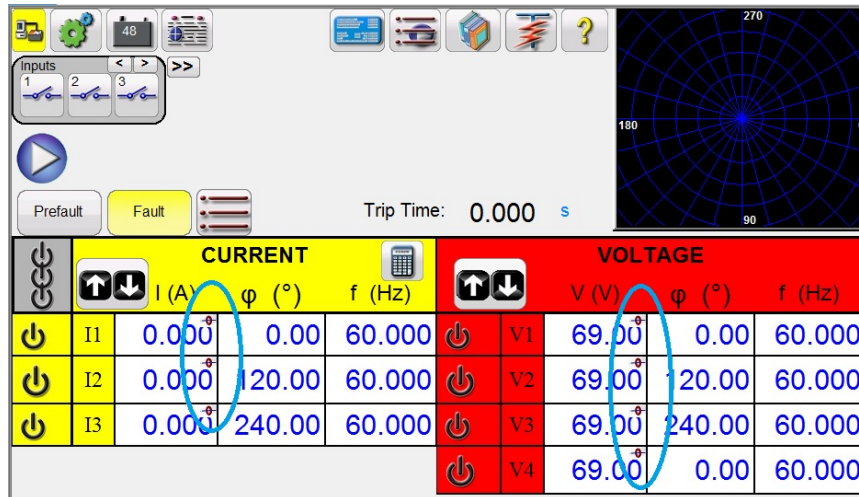

Figure 22 Low Level Outputs Enabled Symbol

After setting low-level outputs, and returning to the main test screen, a  $\Theta$  symbol will appear in the setting values window indicating that low-level outputs are enabled. To clear low-level outputs, return to the Configuration System screen and reset the output levels to their default values.

#### 2.3.1.30 Use PRO Header

In the General Settings section of the System Configuration Screen, the button defaults to RTMS Header. If the user wants to use a PRO (custom) header on their test reports, click on the Use PRO Header button to change the header to a PRO (Custom) version.

#### 2.3.1.31 Update Translations

In the General Settings section of the System Configuration Screen, click on the Update Translations button to access the internet and update the language translations in RTMS (requires internet access).

#### 2.3.1.32 Contact Names (Global)

In the General Settings section of the System Configuration Screen, the button defaults to (Global). The Global setting means that the user only needs to enter the name of the Binary Input(s) once and the name(s) entered will be used in all tests. For example, if you use "Trip" as the name for binary input #1, all other tests in RTMS binary input #1 will be labeled "Trip". To change the input name for every test individually, then click on the Contact Names (Global) button and it will change to (Test Specific).

#### 2.3.1.33 Default As Found/As Left

In the General Settings section of the System Configuration Screen, the button defaults to (Empty). The user will need to select if they want, As Found, As Left, or As Found/As Left results displayed in the test report.

#### 2.3.1.34 ANSI/IEC Button

In the General Settings section of the System Configuration Screen, depending on the PC install selection, the button defaults to either IEC or ANSI. To change the default, press or click on this button. This button affects which test settings models will appear for various tests, i.e. Three Phase Transformer Differential.

#### 2.3.1.35 Flyover Text Button

In the General Settings section of the System Configuration Screen, this button defaults as enabled. The Flyover Text provides a descriptive text of the screen feature based upon the position of the pointer.

#### 2.3.1.36 Voltage Resolution (0.01) Button

In the General Settings section of the System Configuration Screen, this button changes the resolution of the voltage channels from the two decimal default setting of .01 to three decimal .001.

#### 2.3.1.37 TCC Curve Import Button

In the General Settings section of the System Configuration Screen, this button allows the user to import new or custom time curves to the Curve Library. Press this button and using the windows navigator, navigate to PowerDB.v1X.x and find the PdbCurveLib.crv file folder to paste a new/custom time curve. Contact Megger, or your Megger representative, if you have a curve or custom curve that you would like to have added to the curve library.

#### 2.3.1.38 Multi-Instance Button

In the General Settings section of the System Configuration Screen, this button allows the user to select multiple instances associated with Differential relays. For example, some generator differential protection relays also include transformer differential protection. With this button enabled, when the user goes to the Differential test, they will be able to combine up to 4 different differential relays into one test result file.

#### 2.3.1.39 Script Import/Export Button

In the General Settings section of the System Configuration Screen, this button provides the user access to the Test Templates buttons to Import/Export script files for test templates.





#### 2.3.1.40 Screen Exit

To exit the screen and return to the previous screen press the green  check button (you will see this same button on other screens).

### 2.4 **Setting Amplitudes, Phase Angle or Frequency**

Pressing or clicking amplitude, phase or frequency button will display the following pop-up numeric keypad to enter the value you want to change.

### 2.4.1 Numeric Keypad Entry

The numeric keypad entry provides an interface to the user when entering values in the various screens. Pressing or clicking a data entry window (Amplitude, Degree, or Frequency) on the touch screen (right mouse click in the PC version) will activate the Numeric Keypad. Use the numeric keys to type in the value you want and press either the  button or the Balance  button. Pressing the clear all  will clear the value you just entered. Pressing the clear last digit  button will clear the least significant digit of the value in the display window.

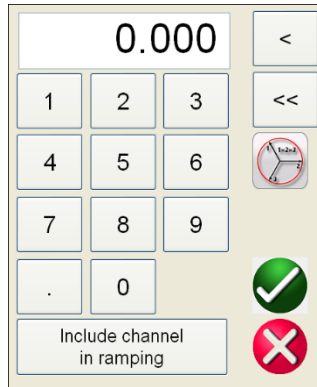







Figure 23 RTMS Numeric Keypad

The  button will enter the value and take you back to the test screen. Press the Balance  button if you want all the voltage or currents values to be the same value. If setting phase angles, and you want all three phases to be shifted the same amount from the defaulted values, enter the value of phase shift desired in the A Phase window, and press . For example, if the default is 0, 120 and 240 degrees, press on A phase current phase angle and enter thirty, press , and the test screen will now show 30, 150, 270 degrees. Pressing Cancel  will return the user to the previous screen that is in use. Pressing **Include channel in ramping** will select that value to ramp when using the control knob (mouse wheel or up down arrow keys on the PC version).

### 2.4.2 Include Channel in Ramping

When this button is pressed the window around the channel magnitude is highlighted in blue indicating that it is now set to be ramped manually using either the Control Knob, or the up down arrows/mouse wheel on the PC keyboard (PC version). If the channel is already selected for ramping, this button will be labeled 'Remove channel from ramping.' The magnitude may now be ramped up or down using the default increment setting. If the user wants to ramp more than one channel, or change the increment, or change the value to be ramped (Amplitude, Phase or Frequency), on the STVI display screen press the Manual Ramp Options button (Control Knob icon, or Up Down Arrows Icon) to display the following screen.

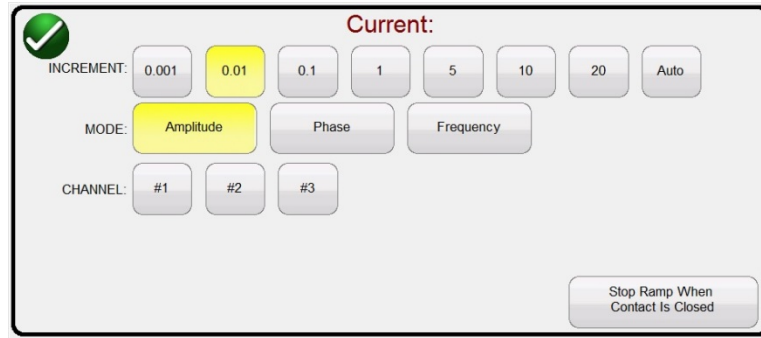

Figure 24 Channel Increment Selection Screen

**INCREMENT**– Select the desired increment. Color change will indicate the value selected.

**CHANNEL** – Select the desired channel(s). The channel button will change color indicating the selected channel(s) to be ramped.



**MODE** – Select Amplitude, Phase, Frequency, or Battery as the value to be ramped. Press or click on the green check button to return to the test screen. One click on the Control Knob or one press of the Up Down arrow on the PC keyboard will change the output by the Increment setting. If the Auto Increment button is selected RTMS will automatically select the increment depending on how fast the control knob is being rotated, the faster the rotation the larger the increment (does not apply when ramping the Battery Simulator).

**Stop Ramp When Contact is Closed** – Select this button for the manual ramp to be stopped when a contact closed is sensed from the relay under test.



#### 2.4.3 Control Knob

The control knob will change the values after Pressing or clicking the display to highlight the value that requires ramping. Clockwise rotation increases and counterclockwise decreases. In the Auto Increment Mode, the control knob uses a speed control algorithm to provide fine adjustment, with a slow rotation (one click equals one digit of the lowest increment level for the value being ramped), and a larger step adjustment with a faster rotation. The Control Knob can also be used to scroll up and down when viewing the test results in the Add Results and View Results screens, or when viewing the Help screen.

#### 2.4.4 Setting Default Voltage Outputs

RTMS comes with factory default settings, which can be changed to suit the user. Using the numeric keypad entry as described above, select the first voltage channel, and enter the desired phase to neutral (earth) value, for example, 67. Press the Balance  button, the green  check button, and all channels will now have a setting of sixty-seven volts. Select the Configuration button, and then select Save as Default (see section 2.3.1.5 Save as Default). The next time the unit is powered up, the default voltage values will all be at 67 V.

#### 2.4.5 Setting Default Current Outputs

Like setting the default voltage values, the Default Current may be changed to suit the user. Using the numeric keypad entry as described above, select the first current channel and enter the desired phase to neutral (earth) value, for example, enter 1, Press the Balanced  button, and  button, and all channels will now have a setting of 1 A. Select the Configuration button, and then select Save as Default (see section 2.3.1.5 Save as Default). The next time the unit is powered up, the default current values will all be at 1 A.

## 2.4.6 Virtual Alphanumeric Keypad

The virtual alphanumeric keypad allows the entry of ASCII text into the appropriate RTMS windows. This keypad is used to enter names for the binary inputs and outputs, names for each state in the Sequence Test, or file names in the file management screen.

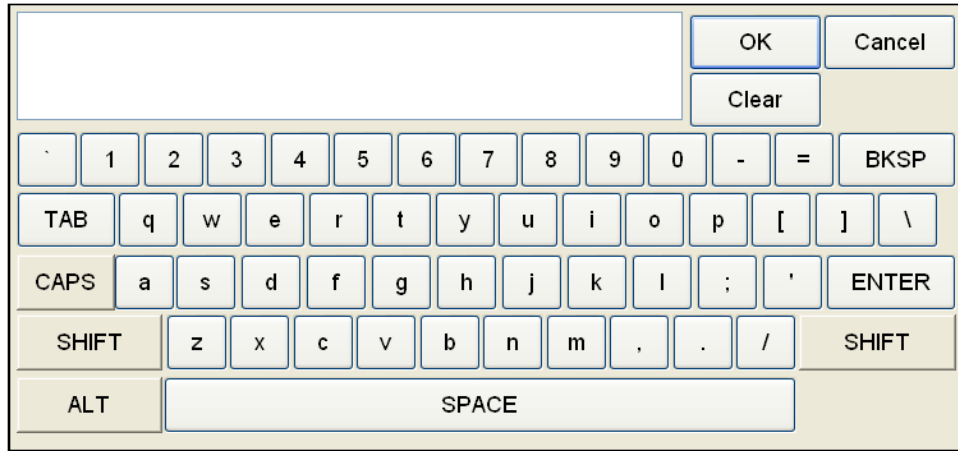

Figure 25 STVI Keyboard

## 2.5 RTMS File Management



The file management display is used by the STVI hand-held controller to access files stored in the STVI's internal memory. This display will allow test files to be loaded, make, or change directories, rename files and directories, delete files and directories that were created by the user. To access the File Management system, touch the File Folder  top center of the test screen. This icon only appears on the STVI hand-held controller, and the On-Board version in the SMRT-D series of units (not on PC version). It provides the user the ability to save tests, or open saved tests. If using the PC version users will have the PowerDB file system to save test (job) files (see PowerDB Help). For STVI hand-held controller, or On-Board users, pressing on the File Folder presents the user with the following tool bar. It defaults with the Save Current Form File Folder highlighted.



Figure 26 STVI File Folder Tool Bar

 Note: Pressing the Power ON/OFF  button will power down the STVI hand-held controller but is not required for a safe shutdown.

Pressing on the highlighted folder will provide the user with the following file explorer.

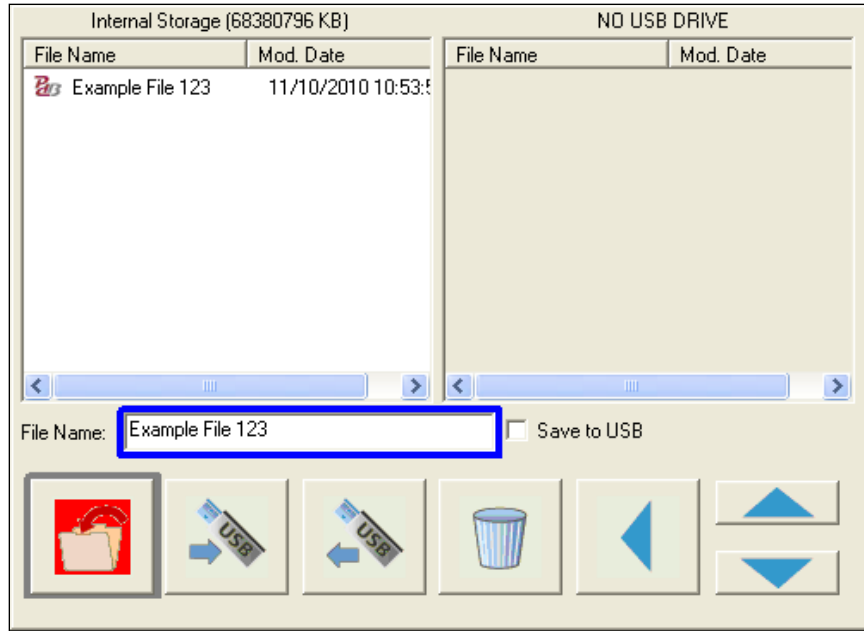





Figure 27 File Folder Explorer

Press in the File Name window and the user will be provided with the virtual keyboard to enter a file name. The file can then be saved to the internal memory or saved to a USB memory stick. This same window is also used to open saved files. To save results directly to a USB memory stick check the Save to USB button. To transfer test results from the STVI hand-held controller, or the SMRT-D series of units, to a USB memory stick use the up down blue colored buttons to select the desired test result to be transferred, and then press on the ⇨USB button. To retrieve a test file from a USB memory stick press on the ⇐USB button to retrieve the selected file from the list of files that appear in the right hand window. To delete a file, use the up down arrows to highlight the file, then press on the trash can icon. The left pointing blue arrow ◀ is the exit button to go back to the test screen. To open

an existing test file, from the File Folder tool bar, press the Open File Folder icon . The user will be presented with the File Folder Explorer. Use the up down blue arrows buttons to highlight the desired file to be opened, and then press the Open File Folder button in the lower left corner. The user will be presented with a menu bar to open a New Test, or to open the file selected showing the date and time of the file saved. Pressing the date/time button will open the saved test. To view the

saved results, press the  More button in the upper right display next to the vector screen, then press the View Report  button.

### 3.0 RTMS – Basic Operating Descriptions

This section describes basic operating procedures for using RTMS with the SMRT units for such applications as basic pickup or dropout, basic timing test, paralleling current outputs, conducting harmonic restraint tests, series of potential sources to provide higher than rated potential, and forming various three phase voltage outputs.

### 3.1 Manual Test Screen

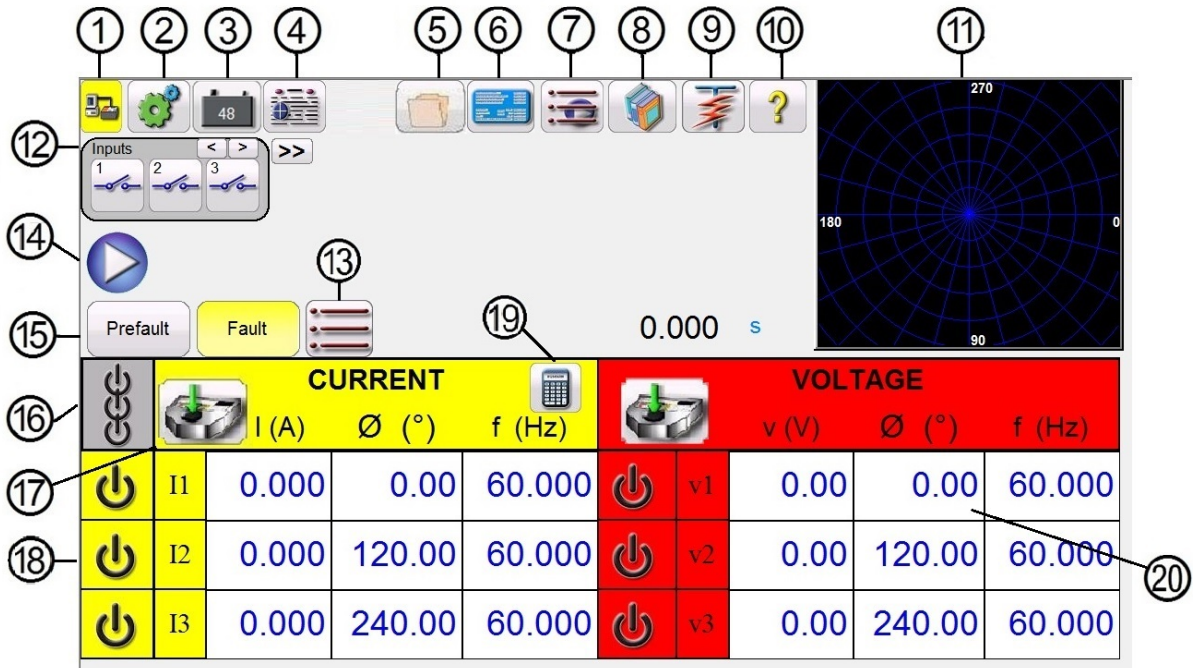



Figure 28 Manual Test Screen

#### 3.1.1 ① Connection button

Press or click on the button and the PC, or STVI hand-held controller, will auto detect the SMRT unit connected and automatically set the IP address through the Ethernet ports. If the button shows two red X's, it indicates that there is no communication to the SMRT unit. If the background color is yellow, it indicates that the unit is 'on-line' and ready for operation. When connection is made (commands sent) the background color will change from yellow to green. In other test screens, a

home  icon will appear in the upper left-hand corner. Pressing the home icon will return you to the manual test screen.

#### 3.1.2 ② The Configuration button

Press this button to go to the RTMS Configuration Screen. See Section 2.3.1 Configuration for more information about the Configuration Screen.

#### 3.1.3 ③ Battery Simulator button

The Battery Simulator button – Turns the Battery Simulator ON and OFF by pressing the button, the background color changes red for ON and gray for OFF. The voltage to be applied is displayed in the button and can be changed by pressing the Configuration button.

3.1.4 ④ Report options button 

This button will add the present test result to the report. It also displays the report and allows the user to name the test, enter limits, comments, or deficiencies. Reports can be saved to the STVI internal memory and transferred to PowerDB via a USB memory stick, or when using a PC to the PC's internal memory. Previous tests results can be loaded, and the 'Retest' option can be used to repeat the test using the same parameters as the previous test.

3.1.5 ⑤ File Folder button 

To access the File Management system, touch the File Folder top center of the test screen. This icon only appears on the STVI hand-held controller and the SMRT-D series of units (not on PC version). It provides the user the ability to save tests, or open saved tests, see Section 2.5 STVI File Management section for more information.

3.1.6 ⑥ Relay Settings button 

To access the Relay Settings data window, press this button. Here the user can Import/Export information relative to the relay under test such as manufacturer, model number, serial number, CT, and PT information, etc. in several different file formats.

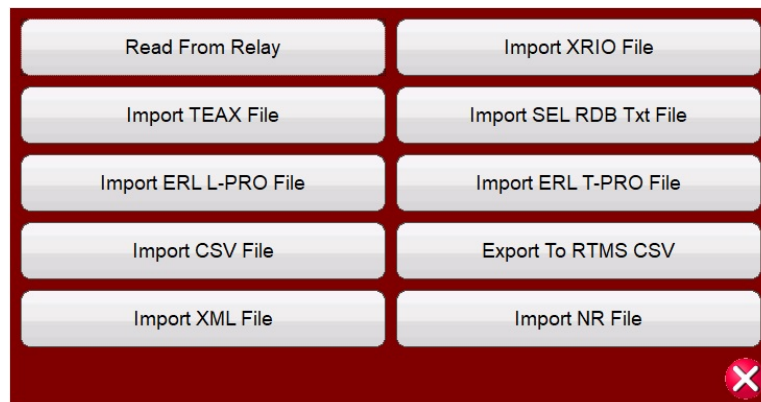

Figure 29 Pressing the Import/Export button provides options.

3.1.6.1 Relay Settings Import/Export Options

3.1.6.1.1 Read from Relay: Press this button to import relay settings directly from the relay. The two formats supported are SEL Serial, and Modbus. The Modbus protocol is used for downloading settings from GE Multilin Type UR relays.

3.1.6.1.1.1 Read from SEL Relay: The first step is to establish communications with the relay under test. This will require the use of a USB serial port on either the PC, or the relay test system.

1. Press or click on the SEL Relay button and the Generic SEL communication screen will appear like the following figure.

Figure 30 Generic SEL Communication Screen

Note that the typical default Read Commands, Passwords Level 1 and 2, and COM Port assignment and Baud rates are preset.

2. Click on GENERIC SEL button to select the relay under test, see the following figure.

Figure 31 List of Available SEL Relays

3. Select the relay under test. If the relay is unavailable, select GENERIC SEL.
4. Read Commands row can be manually edited and can be found in the instruction manual of the relay in case special commands are required.
5. Enter Level 1 and Level 2 Passwords if different from the default.
6. Connect the SEL USB serial cable to the relay serial communication port.
7. Select the desired Relay COM port for your PC or the relay test system. If the relay test system you are using is a SMRT-D model use the highest COM Port number indicated. If using a PC select the appropriate COM Port for the USB serial adapter that you are using.
8. Press or click on the Refresh button to detect the COM Port to which the relay is connected.
9. A dropdown will appear once the COM Port field is clicked.
10. Choose the Baud Rate used by the relay and then press Read from Relay
11. If PowerDB is under simulation mode, a message will appear as shown below.

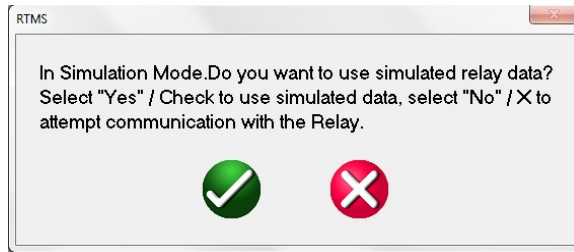



Figure 32 Simulation Setting Download Message

12. Selecting Red Cross will attempt to read the settings from the relay.
13. There will be a logging into relay message banner to indicate the handshaking process has started.
14. Once all the settings are read from the relay, the user can then test the relay using the relay settings. In some relays there are hundreds of settings, so it may take several minutes to download all the settings depending on the baud rate.

3.1.6.1.1.2 Read from Modbus Relay:

Modbus read only works if there is already an existing setting with the Modbus address. If there is no setting available in RTMS, new settings must be created.

1. To create a new setting, press or click on the Edit Mode button to enable.
2. Click or press on the Create a New Setting icon  to add a new setting, then provide a folder name, and a setting name of your choice.
3. Click or press on Show Modbus button and enter the address for the settings that need to be read.

Folder Name	Setting Name	Comment		
*NOTE: Group Name and Setting Name should be only alphabetic and numeric characters. Spaces and special charactes will be replaced with an _ when creating the Script Name.				
Script Name	Type	Default	Min	Max
	Float			
Allow Infinity				
Custom Script Tag				Edit Import Mappings
Hide Modbus Modbus Settings (Final value = (Raw * Increment)/Scale)				
Address	SCALE	Increment	Number of Registers	Modbus Type
-1	1	1	0	int



 

Figure 33 Show Modbus settings.

Typically, Scale = 1, Increment = 1, Number of Registers = 1 and Modbus Type = int, but they are all editable as per relay's instruction/communication manual

**Note:** Modbus Address in RTMS are in decimal values

4. Click Edit Mode again to disable and then Click Import/Export icon to see all the setting options.

3.1.6.1.1.2.1 Read from Modbus Relay with Serial Communications:

1. If using the serial port, connect a USB serial cable to the relay serial communication port. Press or click on the Modbus Relay button and a Modbus communication screen will appear like the following figure.

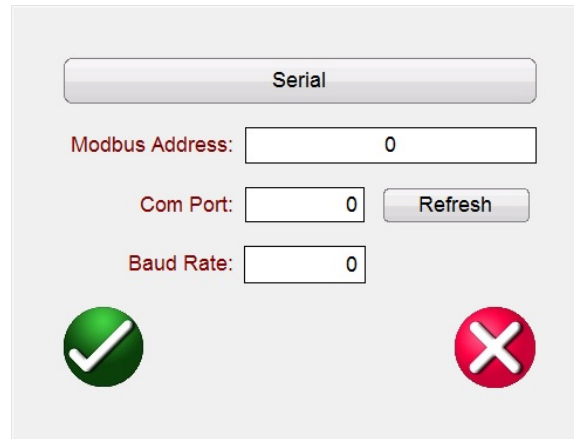

Figure 34 Modbus Serial Communication Screen

2. Select the desired Relay COM port for your PC or the relay test system. If the relay test system you are using is a SMRT-D model use the highest COM Port number indicated. If using a PC select the appropriate COM Port for the USB serial adapter that you are using.
3. Once the COM Port is assigned, press, or click on the Read from Relay button.

3.1.6.1.1.2.2 Read from Modbus Relay with Ethernet Communications: If using Ethernet port, press or click on the Serial button to change it to Ethernet and the following communication screen will appear.

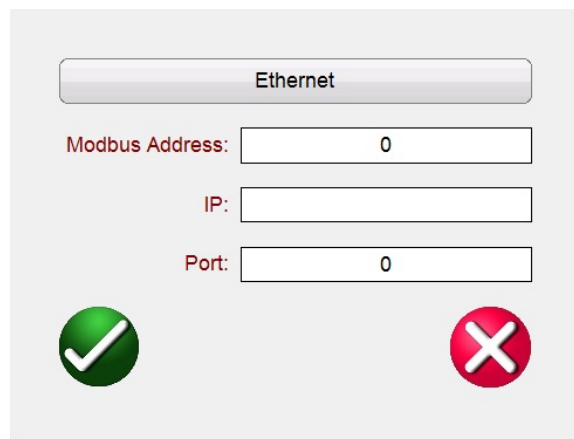
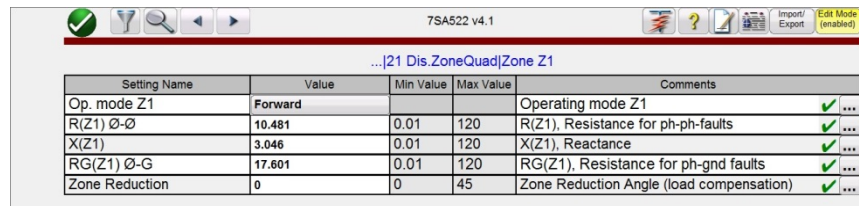

Figure 35 Modbus Ethernet Communication Screen

1. Enter the Modbus address for the relay under test. Typically, it is either 1 or 254. It can be found in communication setup settings of the relay.
2. Enter the IP Address of the relay found under TCP/IP section of the relay Modbus settings.
3. Enter the TCP/IP Port number. It can also be found in the relay settings.
4. Press the Green check button to read settings from the relay.

If the settings are read successfully, the settings will appear, else 0 will appear indicating failure in communication.

3.1.6.1.2 Import XRIO File: Press this button to import relay settings in the XRIO file format. XRIO files are created by software from various relay manufacturers. Some specific relays in the Relay Library include the ability to import the XRIO relay settings and create the relay operating characteristics from these settings. A couple of examples are the ABB REL-670 V2.0.0, and Siemens 7SA632 V4.6. To import the relay settings using the XRIO import click on the relay manufacturer, click on the relay, i.e., Siemens, 7SA632 v4.6. Upon clicking on the relay, the Settings window will appear see the following figure. Click on the Import/Export button and navigate to the 7SA632 V4.6 XRIO file<sup>1</sup>, and click on the file. A message window will appear informing you once the settings import has been completed.



Setting Name	Value	Min Value	Max Value	Comments
Op. mode Z1	Forward			Operating mode Z1 ✓***
R(Z1) Ø-Ø	10.481	0.01	120	R(Z1), Resistance for ph-ph-faults ✓***
X(Z1)	3.046	0.01	120	X(Z1), Reactance ✓***
RG(Z1) Ø-G	17.601	0.01	120	RG(Z1), Resistance for ph-gnd faults ✓***
Zone Reduction	0	0	45	Zone Reduction Angle (load compensation) ✓***

Figure 36 Siemens Zone 1 XRIO Relay Settings Import

3.1.6.1.3 Import TEAX File: Press this button to import relay settings in the Siemens TEAX file format.

3.1.6.1.4 Import SEL RDB Txt File: Press this button to import relay settings in the SEL Relay Data Base Text file format. This feature requires user to import the desired SEL RDB files, in advance, into a file folder under the MY Documents/PowerDB directory.

1. Click Import SEL RDB Txt File button under Import/Export button.
2. Choose the setting file saved on your PC and click OPEN.
3. A pop up message would appear shown in the next figure.

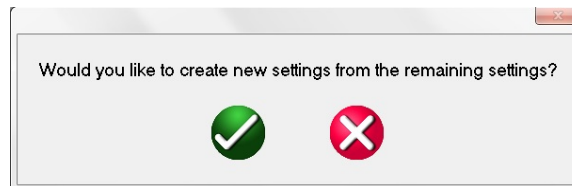

Figure 37 Create New Setting Message

<sup>1</sup> Requires user to import the desired XRIO files, in advance, into a XRIO file folder under the MY Documents/PowerDB directory.

4. Green Check button – This button will add settings in addition to the existing settings (if already read and stored before). Red Cross button- This button will overwrite existing settings (if already read and stored before).

3.1.6.1.5 Import ERL L-PRO File: Press this button to import relay settings in the ERL L-PRO relay file format.

3.1.6.1.6 Import ERL T-PRO File: Press this button to import relay settings in the ERL T-PRO file format.

3.1.6.1.7 Import CSV File: Press this button to import relay settings in the CSV file format. Different options are available, see the following figure.



Figure 38 Import CSV File Formats

RTMS CSV files are now Unicode encoded. Microsoft Excel only supports Unicode “csv” files with tab separators. To be able to open and edit the files in Excel, RTMS now exports tab separated files instead of comma separated files. **The RTMS CSV import is not backwards compatible with previous versions of the export.**

3.1.6.1.8 Export RTMS to CSV File: Press this button to export relay settings in the RTMS CSV file format. RTMS CSV Exports can export the active settings, or the settings created during the previous import:

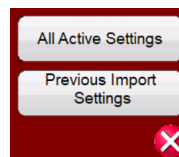

Figure 39 Export to RTMS CSV File Options

- a. This can be used to find the mappings from the previous import that need to be added to the existing settings.
  - i. import from XRIO/Relay CSV/Read from relay/etc.
  - ii. export “Previous Import Settings” to CSV
  - iii. find settings that were not imported during the last import (Blue ? in RTMS relay settings screens)
  - iv. find the setting in the csv file and copy the value in the “ImportMappings” column into the “Edit Import Mappings” on the setting.
- b. This can also be used in conjunction with the RTMS CSV Import to create new settings
  - i. import from XRIO/Relay CSV/Read from relay/etc.

- ii. export "Previous Import Settings" to CSV
- iii. eliminate unwanted settings using Excel
- iv. import RTMS CSV

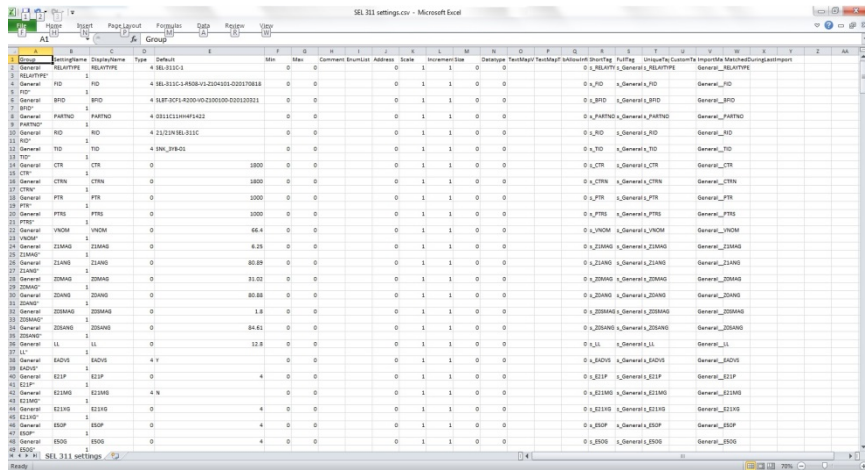

Figure 40 Example Excel RTMS CSV Export for Previous Imported Settings File

3.1.6.1.9 Import XML File: Press this button to import relay settings from ZIV relays in the XML file format.

3.1.6.2 Relay Settings Import/Export Edit Mode Enabled: There are two applications for the use of this button. One is to create new relay settings. The other application is to compare or edit imported settings.

3.1.6.2.1 Create New Relay Settings

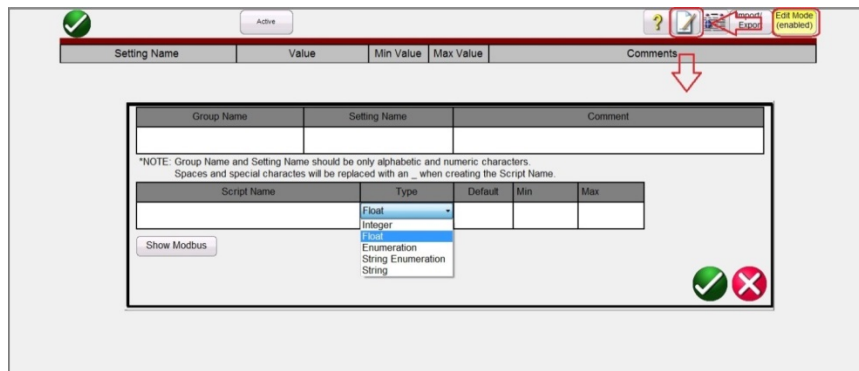

Figure 41 Relay Settings Edit Mode

Pressing the Edit Mode Enabled button and then the Create a New Setting button will provide the figure above and will allow the user to create a new setting Group and Setting Name. Pressing or clicking the **Type** window is to identify whether the setting is one of the following:

**Float** is a floating point number indicating that a decimal value may be entered in the Relay Settings field. The number entered may also be an Integer with no decimal.

**Integer** is several whole values with no decimal. A decimal value placed in an Integer field in the Relay Settings will evoke an error message advising that an invalid entry has been attempted.

**Enumeration** is to create an enumeration of variables and or values for a drop list of valid Values in the Relay Settings. The list is entered in the Enum Options field with no spaces with each item separated by a comma.

**String Enumeration** is to enter the comma delimited list of values or string variables to be in the Values drop list in the Relay Settings. Default is a blank field and null for all other Data Types.

Entries may be numeric 0.5, 0.6, 0.8, 1, 2, 3.0 or string Pass, Fail, Yes, No

- Note: No spaces allowed for enumeration of values.

**String** is to set the variable Name as a non-numeric value. If a String is to have a value, it must be converted from String to Numeric values using Expressions.

To convert a string to a number:

`c = val(b$)` results in the string

`b$ = 10$` being set to the number `c = 10`.

Pressing the Show Modbus button will provide the following setting screen.

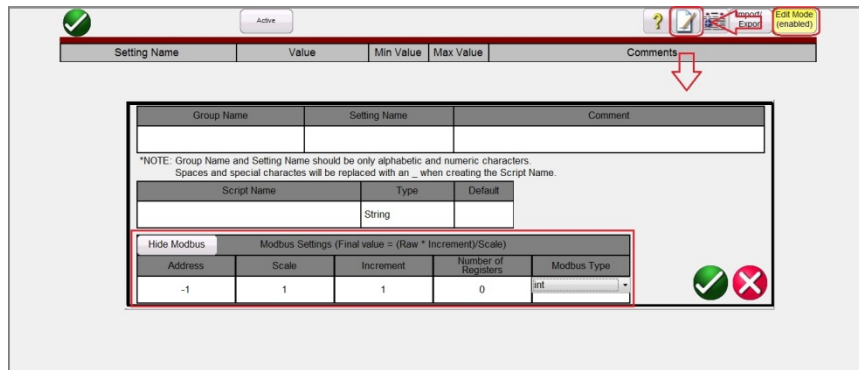

Figure 42 Adding Modbus Settings

Modbus **Address** field is provided to enter the memory map address **Addr** given by the relay manufacturer.

### 3.1.6.2.2 Edit Imported Settings

Select the Edit Mode button, and then import the settings from a file. Upon importing the settings, the settings may appear as shown in the following example.

Setting Name	Value	Min Value	Max Value	Comments
Line Angle	69	30	89	1105 Line Angle(degrees) ✓...
x km	0.091	0.001	1.9	1110 x' - Line Reactance per length unit (ohr) ✓...
Line Length km	23.2	0.1	1000	1111 Line Length (km) ✓...
x mi	0.0484	0.001	15	1112 x' - Line Reactance per length unit (( ?) ✓...
Line Length mi	62.1	0.1	650	1113 Line Length (miles) ? ✓...
RE over RL Z1	0.42	-0.33	7	1116 Zero seq. comp. factor RE/RL for Z1 ✓...
XE over XL Z1	0.54	-0.33	7	1117 Zero seq. comp. factor XE/XL for Z1 ✓...
RE over RL Z1B TO Z5	0.42	-0.33	7	1118 Zero seq. comp. factor RE/RL for Z1B... ✓...
XE over XL Z1B TO Z5	0.54	-0.33	7	1119 Zero seq. comp. factor XE/XL for Z1B... ✓...
K0 Z1	1	0	4	1120 Zero seq. comp. factor K0 for zone Z1 ? ✓...
Angle K0 Z1	0	-135	135	1121 Zero seq. comp. angle for zone Z1 (( ?) ✓...
K0 higher Z1	1	0	4	1122 Zero seq. comp. factor K0, higher zones > ? ✓...
Angle K0 higher Z1	0	-135	135	1123 Zero seq. comp. angle, higher zones >Z ? ✓...

Figure 43 Example Import Settings Edit Mode

If all the settings are properly mapped and imported, then a green checkmark ✓ will appear in the right side of the display next to the Edit function button. Only settings that are already in the settings list with non-empty mappings will be matched. If the setting ID is mapped but does not match with the imported file, then a ? will appear indicating there may be an issue with the imported setting value ID. If there is a blank next to the edit button means that a value was not mapped. Mappings are done searching up to three different nomenclatures, such as file name, group name, setting name, ID number, etc. This allows for different firmware versions for the same model of relay, where a file ID or setting nomenclature was changed. By pressing the Edit button, then using the Edit Import Mapping button the user can enter the new nomenclature or setting name.

Folder Name	Setting Name	Comment
General	Z1EXTMP	

\*NOTE: Group Name and Setting Name should be only alphabetic and numeric characters. Spaces and special characters will be replaced with an \_ when creating the Script Name.

Script Name	Type	Default	Min	Max
s_Z1EXTMP	Float	1	0	0

Allow Infinity

Custom Script Tag

Edit Import Mappings

Show Modbus

✓ ✗

Figure 44 Edit Import Mappings

Clicking on this button will provide the user with the Edit Mappings Screen, where up to three search nomenclatures might already be listed. Note: many are only one line. The software imports the relay settings using these nomenclatures. If the manufacturer, i.e., new firmware version release, changed the setting ID then the user can add the new setting ID below the other listed nomenclatures. The import mappings should be 1 mapping per line. See the following example.

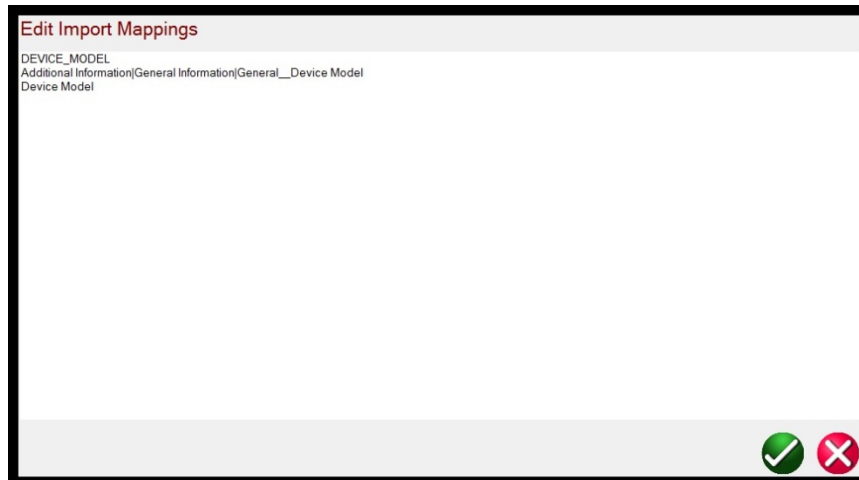

Figure 45 Example of three lines of nomenclature.

After entering the new setting ID, go back and import the settings and the blue ? should change to a green ✓.



### 3.1.7 ⑦ Select New Test button

Press this button to access the list of tests that are available. The RTMS test menu is in two sections, Standard and Enhanced. The Standard section tests that are available are Ramping, Timing, Sequence, Impedance, Differential, Meter and for those units equipped with the Transducer Hardware Option the Transducer Test. With the IEC 61850 GOOSE option enabled in the SMRT hardware the Megger GOOSE Configurator (MGC) provides mapping of the binary inputs and outputs of the SMRT test set to the desired GOOSE messages. With IEC 61850 9-2 LE Sampled Values option enabled in the SMRT hardware, Sampled Values Analyzer (SVA) is used as a testing tool that provides the ability to configure a maximum of three Sampled Value (SV) streams compliant with first edition of IEC 61850 9-2 LE to be used in process bus applications for digital substations. The Enhanced section is only available in units with the Enhanced software enabled (see SMRT Ordering Information for details).

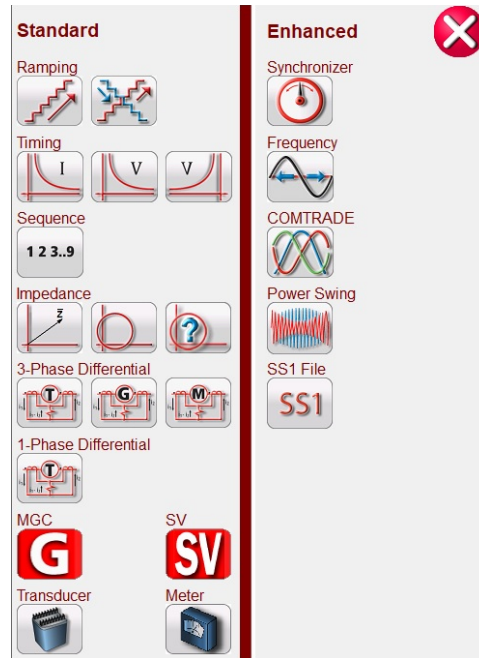





Figure 46 Standard and Enhanced Software Test Menu List

See the following descriptions.

3.1.7.1 Ramp Selection buttons 

The Simple Ramp  button is used for doing pick up or drop out tests on any type of relay. It can be used to perform a general-purpose linear step ramp, pulse ramp, or pulse ramp binary search. The Advanced Ramp  button allows the user to perform a continuously smooth ramp with x/s increment/second, as well as other more complex ramps.

3.1.7.2 Timing Test buttons 



There are three Timing Test buttons, I (Overcurrent) U/V (Over and Under Voltage). Press the appropriate button to go to the desired Timing Test screen to easily test time overcurrent, over voltage and under voltage relays. RTMS has ANSI, IEEE and IEC standard time curve algorithms built in. In addition, it includes time curves and time curve algorithms for hundreds of different specific relays selectable by manufacturer, relay model number, and curve shape (inverse, very inverse, definite time etc.).

3.1.7.3 Sequence 1, 2, 3...9 button 



Press this button to go to the Sequence Test screen used for testing reclosing type relays, setting up multiple vectors and general multi-state sequencing. It also includes Transient Earth Fault simulation, including intermittent transients.

#### 3.1.7.4 Impedance button

Press the  button to go to the Click On Fault relay test screen for testing impedance relays.

Press the  Easy-Z button for a quick test on an impedance relay. Press the  button to test impedance relays where the impedance characteristic is unknown.

#### 3.1.7.5 Differential button

Press the  button to go to the Transformer Differential test screen for testing 3 Phase current, or 1 Phase differential relays. Press the  button to go to the Generator Differential test screen.

Press the  button to go to the Motor Differential test screen.

#### 3.1.7.6 Megger GOOSE Configurator button

Pressing the Megger GOOSE Configurator button provides access to the MGC software for testing IEC 61850 relays. This feature is enabled when ordering the IEC GOOSE Hardware license at purchase or as an upgrade. Optional stand-alone MGC Software is available to test and commission IEC61850 compliant devices. MGC stand-alone Software is part number: 1007-246.

#### 3.1.7.7 Megger Sampled Values Configurator button

Pressing the Megger Sampled Values Configurator button provides access to the SVA software for testing IEC 61850 relays with IEC 61850-9-2 LE Sampled Values.

#### 3.1.7.8 Transducer button

Press this button to go to the Transducer test screen for testing single phase and three phase transducers. This software feature only works with units that have the Transducer Hardware Option installed (see SMRT Ordering Information for details).

#### 3.1.7.9 Meter button

Press this button to go to the Meter test screen for testing the meter function of microprocessor-based relays.

#### 3.1.7.10 Synchronizer button

Press this button to go to the Synchronizer test screen for testing synchronizing and sync-check relays. This software feature appears with units that have RTMS Enhanced Option enabled.

### 3.1.7.11 Frequency button

Press this button to go to the Frequency test screen for testing Frequency sensing relays. This software feature only appears with units that have RTMS Enhanced Option enabled.

### 3.1.7.12 COMTRADE button

Press this button to go to the COMTRADE test screen. This software feature appears with units that have RTMS Enhanced Option enabled.

### 3.1.7.13 Power Swing button

Press this button to go to the Power Swing test screen. This software feature only appears with units that have RTMS Enhanced Option enabled.

### 3.1.7.14 SS1 button

Pressing the SS1 test button provides access to test relays using an SS1 file from Aspen One-Liner or Electrocon CAPE power system simulation software products. This software feature only appears with units that have RTMS Enhanced Option enabled.

## 3.1.8 Relay Library button

Pressing the Relay Library Plan button provides access to hundreds of relay test plans from multiple relay manufacturers, or the RTMS Template Manager. Relay tests are performed in accordance with the relay manufacturer's specifications. Pressing this button will reveal the following figure.



Figure 47 Relay Library Options

### 3.1.8.1 Select Relay Manufacturer button.

Pressing this button will provide access to over three dozen different relay manufacturers (listed in alphabetical order) and ANSI, IEC, IEEE, and Generic test templates. See the following figure for the first list.

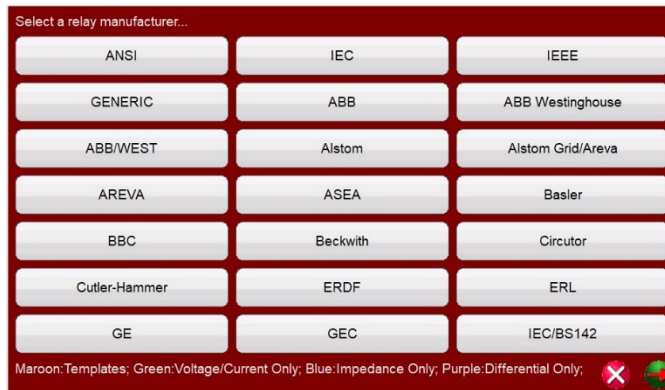

Figure 48 Page 1 Select Relay Manufacturer screen.

Press the red arrow inside the green button on the lower right corner to access page 2 listings.

### 3.1.8.2 Template Manager button

Pressing the Template Manager button will provide the following figure.

<input type="checkbox"/>	Update	Path	Name	Cloud	Cloud Mod Date	Local Mod Date	Size	Local Size	Change Log
<input type="checkbox"/>		ABB Westinghouse	ITH	Same	8/24/2022	8/24/2022	16.33kB	16.33kB	...
<input type="checkbox"/>		ABB Westinghouse	MG-6	Same	8/23/2022	8/23/2022	42.69kB	42.69kB	...
<input type="checkbox"/>		ABB	RELS21 v2.3	Same	8/9/2022	8/9/2022	0.67MB	0.67MB	...
<input type="checkbox"/>		ABB	RELS31 v2.3	Same	8/10/2022	8/10/2022	0.67MB	0.67MB	...
<input type="checkbox"/>		ABB	RELS61 v2.3	Same	8/10/2022	8/10/2022	0.67MB	0.67MB	...
<input type="checkbox"/>		ABB	SA-1	Same	8/5/2022	8/5/2022	0.72MB	0.72MB	...
<input type="checkbox"/>		Alstom	P545	Same	8/22/2022	8/22/2022	0.68MB	0.68MB	...
<input type="checkbox"/>		Alstom	P546	Same	8/18/2022	8/18/2022	1.00MB	1.00MB	...
<input type="checkbox"/>		GE	HFA54	Same	8/24/2022	8/24/2022	44.30kB	44.30kB	...
<input type="checkbox"/>		GE	HFC-21B	Same	8/24/2022	8/24/2022	14.66kB	14.66kB	...
<input type="checkbox"/>		GE	ICE-52B	Same	9/1/2022	9/1/2022	0.52MB	0.52MB	...
<input type="checkbox"/>		GE	ICW-51A	Same	9/1/2022	9/1/2022	0.51MB	0.51MB	...
<input type="checkbox"/>		GE	Multilin 350	Same	8/31/2022	8/31/2022	2.26MB	2.26MB	...
<input type="checkbox"/>		GE	P642	Same	8/31/2022	8/31/2022	0.74MB	0.74MB	...
<input type="checkbox"/>		GE	P841	Same	8/31/2022	8/31/2022	0.73MB	0.73MB	...
<input type="checkbox"/>		GE	P94V	Same	9/21/2022	9/21/2022	0.58MB	0.58MB	...
<input type="checkbox"/>		GE	PVD21A	Same	8/19/2022	8/19/2022	1.52MB	1.52MB	...
<input type="checkbox"/>		GE	PVD21B	Same	8/19/2022	8/19/2022	1.52MB	1.52MB	...

Figure 49 Example of Template Manager screen.

This screen will change as newer test templates are entered into the cloud templates storage. The user can manage their test templates by downloading new and revised test templates from the cloud from this screen.

#### 3.1.8.2.1 Update Local with Newer button

Here the user can update their test templates by pressing this button. Pressing the button, the user will be presented with a message, see the following figure.

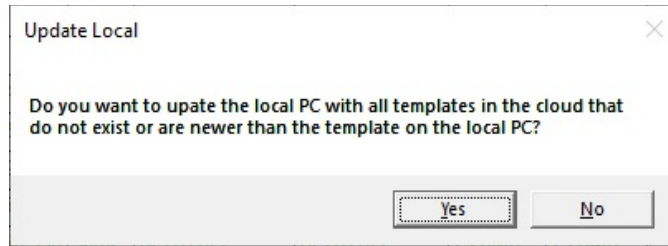

 Note the message states that “newer” templates than the template on the local pc will be downloaded. If you do not wish to download an updated template(s) from the one you have been using, then you will need to the next option.

#### 3.1.8.2.2 Update Local with Missing Only button

Here the user can update their “missing only” test templates by pressing this button. Pressing the button, the user can update their test templates from the cloud with templates that are missing in their present list.

#### 3.1.8.2.3 Update Local with Checked button

If a revised updated test template is available on the cloud, the user can update those selected (checked) templates by pressing this button.

#### 3.1.8.2.4 Open in RTMS button

The user can select a test template from those listed and open it by pressing this button.

#### 3.1.9 Predefined Test button

Pressing the Predefined Test button provides access to Predefined Tests, created by either Megger or users, in Pdb Tst file structure, see the following example on a PC.

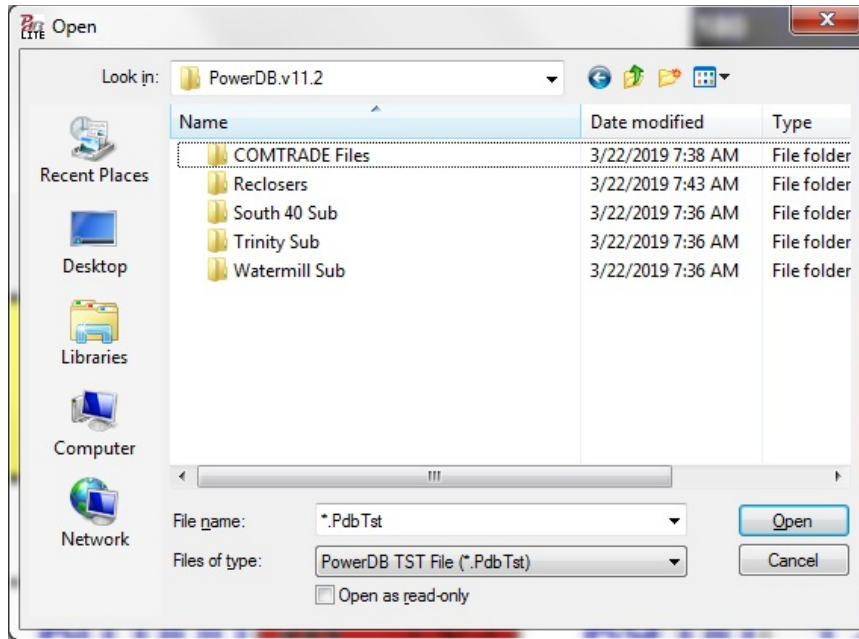

Figure 50 Preconfigured Test File Folders

These test plans can be more generic or extremely specific. Users can perform manual or automated tests, save them in the database, and then reselect them to reuse as a Predefined Test. If no tests have previously been executed, pressing this button will provide the following screen.



Figure 51 Preconfigured Test Screen

As an example, if the user had previously run tests for overcurrent relays, you might see something like the following example.

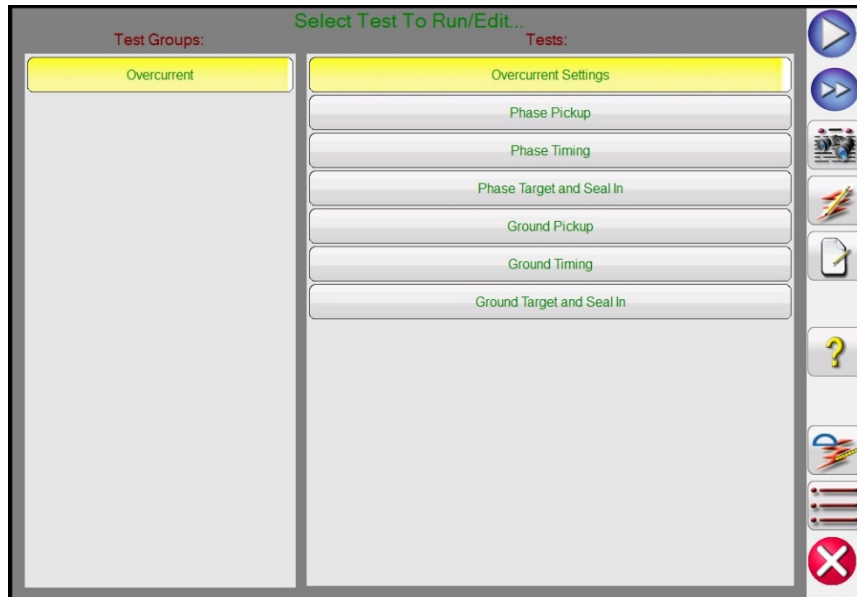



Figure 52 Preconfigured Tests for Overcurrent Relays

As shown in the above figure, the Test Groups are Overcurrent, and Tests are listed in the right half of the screen. The following are descriptions for the tools.

3.1.9.1 Run Test button  Press the Run Test button to execute the highlighted individual test.

3.1.9.2 Run All button  Pressing the Run All button the user will see the following options.

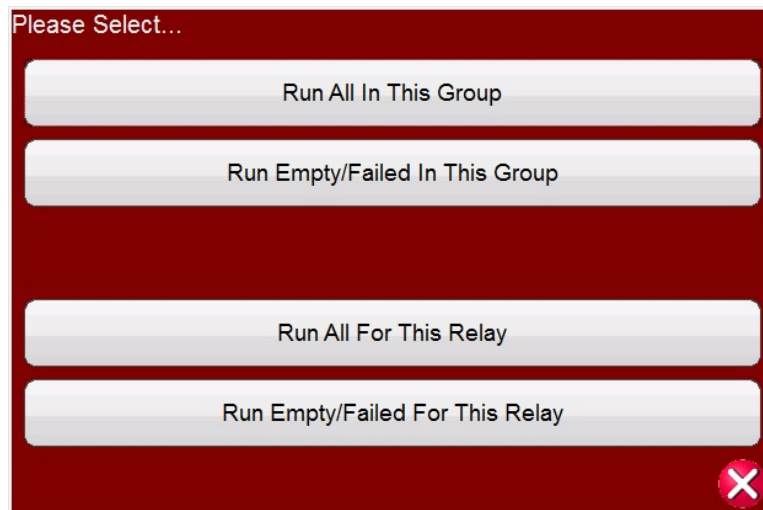



Figure 53 Preconfigured Play All Options

3.1.9.3 View Results button 

Press the View Results button to view the test report.

3.1.9.4 Go to Test Screen button 

Press the Go to Test Screen button to go to the selected test.

3.1.9.5 View/Edit Notes button 

Press the View Edit Notes button to view the test notes or to add notes.

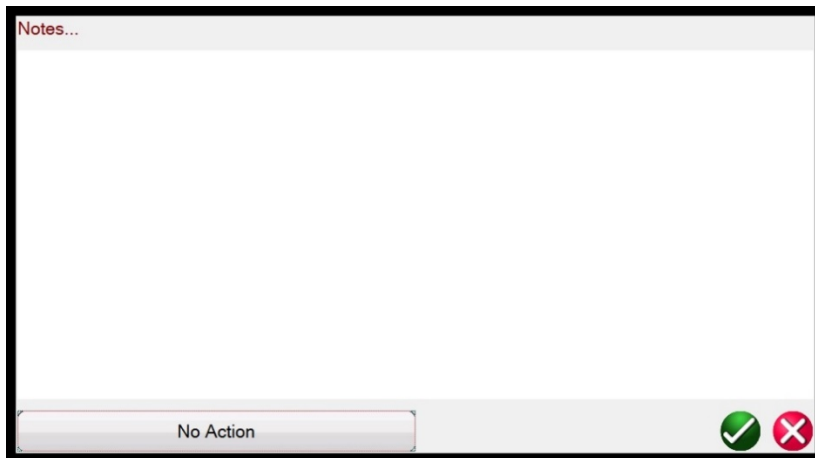



Figure 54 Test Notes Screen

Pressing the No Action button at the bottom of the note screen will provide options as shown in the following figure.



Figure 55 Test Notes and Display Action

The user can select to have the test notes displayed upon running the test, or not, or display for X number of seconds.

3.1.9.6 Help button 

The Help button is sensitive to the test and will take the user to this section of the manual.

3.1.9.7 Edit Test Attribute Script button 

Pressing this button will take the user to the Edit Test and Attributes screen as shown in the following figure.

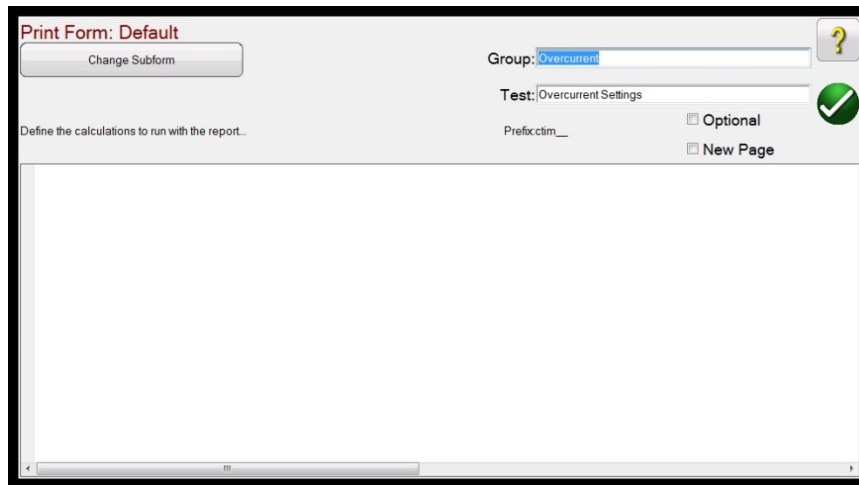

Figure 56 Edit Test and Attributes Screen

If the test uses a script file, the script will appear on the screen. In the example above the test is a Megger test file, therefore, no script appears. The **user can change the Group and Test names**. Checking the **Optional** button will exclude this test from Pass/Fail evaluation in the Test Report. Checking the **New Page** will add this test as a new page in the test report. Pressing the **Change Subform** button will present the following options to the user.

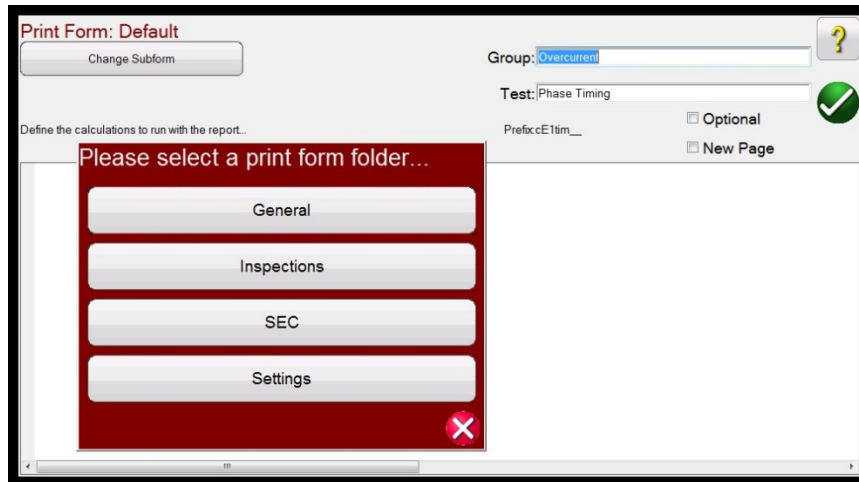

Figure 57 Change Sub form Options in the Test Edit and Attributes Screen

Selecting any of the listed options will present the user with multiple lists of print labels.

### 3.1.9.8 Extended Actions List button

Pressing this button will provide a list of extended actions that the user may want to use, see the following.

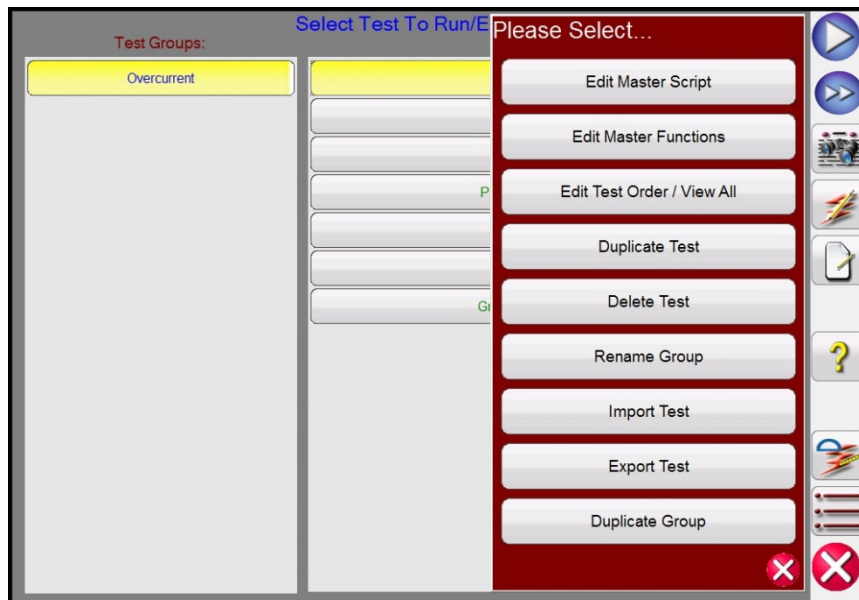

Figure 58 Extended Action List

Here the user can duplicate a Group of tests or duplicate any individual test. Test can be Imported or Exported. The Group can be renamed. Tests can be deleted or edited. If the test has a script file, it can Edited here.

### 3.1.10 Help button

Pressing this button will provide Help for both software and hardware, including a hardware system reset.

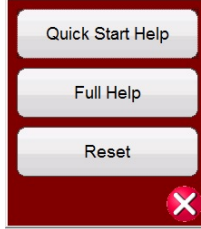

Figure 59 Help List

For some test screens the Help button is sensitive to the test. For example, in the Click on Fault Impedance test screen pressing the Help button will bring up information relative to testing impedance relays.

#### 3.1.10.1 System Reset button.

In addition to information regarding software and hardware, Help will also provide a system Reset. Pressing the Reset button will reset the unit back to power up default settings. Use this button to reset the VIGENS after they have alarmed off due to either a short circuit on the voltage channels, or an open circuit on the current channels.

### 3.1.11 Phase Vector Screen

This display shows the phases and angles of the test values. Pressing on the screen display provides a full screen display of the test vectors with amplitudes and phase angles. Pressing it again reduces it back to its original size. If used with the Symmetrical Components the display will display the positive, negative and zero sequence component values.

### 3.1.12 Binary Input Dialog Box

The Binary Inputs selection bar and More  button – The first 3 binary inputs are displayed showing their present state. Pressing binary input windows #2 and above will display the dialog box shown in Figure 56A. For conducting a timing test, pressing binary input #1 will display the dialog shown in Figure 56B.

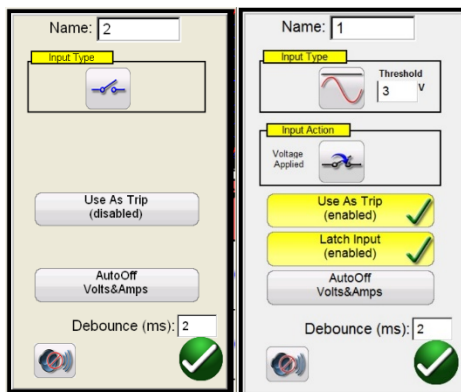



Figure 60 A Binary Input #2 Monitor Mode/60 B Binary Input #1 Time Trip Mode

Binary Input #2 in Monitor Mode is sensing for closing of normally open relay contacts, as displayed by the icon in the Input Type window or opening of normally closed relay contacts. When the contacts close the LED for the selected binary input on the connected unit will light up. If the Horn button  is selected to ON, the horn will sound. If a normally closed contact opens the light on the connected unit will go out (with horn on, the horn will go off). To sense voltage, press the Input Type contact icon and it changes showing a DC/AC voltage sine wave . In Voltage Sensing Mode, the unit is sensing the application or removal of an AC or DC voltage. A programmable voltage threshold is available on binary inputs 1 & 2, with a programmable range from 2 to 150 V AC/DC.

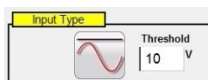

Figure 61 Programmable Voltage Setting Window

The programmable threshold voltage default value is 10 Volts. Press or click in the setting window and enter the desired voltage threshold.

For Timing Tests press either binary #1 or press the **Use as Trip (disabled)** button in binary #2, and the dialog box changes to **Use as Trip (enabled)**. The default settings are dry contacts as indicated by the Input Type, and Input Action defaults to show the Closing of the Normally Open contacts. To change to the opening of Normally Closed contacts press the Input Action icon and it changes to show closed contacts opening. Pressing the **Auto Off** button will provide the user with three selections: **Voltage**, **Current**, or **Voltage & Current**.

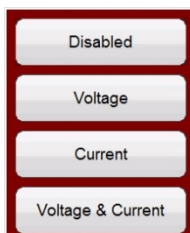

Figure 62 Auto Off Options

This provides auto off, of the voltage, current or voltage & current channels upon tripping of the relay. For most timing applications the timer should be set to **Latched Input (enabled)** mode, which means the timer will stop on the first contact closure. The **Latched Input (disabled)** mode means if the contact bounce the timer will include the bounce time.

The Debounce time is set in ms. The trip contacts must stay closed for the debounce time for the time test to be true. If the contacts open in less than the set debounce time the timer will continue to run. Once the input condition is true then the time test will conclude. The trip time displayed will be the total test time less the debounce time.

### 3.1.12.1 More button

Pressing or clicking on the more button (next to binary input buttons) reveals more Binary Input and Output options as well as more options regarding displayed values.

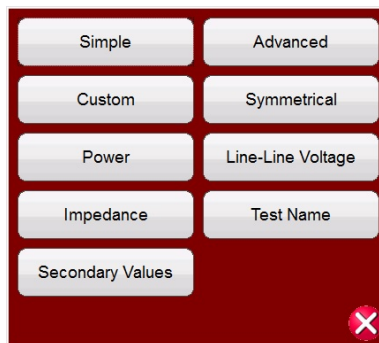

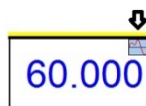

Figure 63 Binary Input and Output Options and Displayed Values

3.1.12.1.1 **Simple** Mode button: The unit defaults to the Simple Mode where only 3 binary inputs (SMRT1 will show 1) are shown.

3.1.12.1.2 **Advanced** button: Press or click on the Advanced button to reveal the first 7 Binary Inputs that are available and the first four Binary Outputs (SMRT1 will show 1 of each). Pressing the <> buttons will advance the displayed binary inputs or outputs.

3.1.12.1.2.1 **Harmonic Waveform** selection button: Press or click on the Waveform  selection button to view the available programmable waveforms. The unit defaults to the 1 position, which provides a sine wave with the fundamental power up default frequency. The user can define up to four waveforms, the default 1 (Fundamental), plus a Second (2), Third (3) and Fourth (4) Waveforms. All four waveforms will be summed together to create a complex waveform from any, or all, of the selected outputs. If no value is entered for the second, third or fourth waveforms then the output will simply be the Fundamental default frequency sine wave. Any amplitude, phase angle or frequency can be specified for each of the four waveforms. This feature is normally used when generating a second, third or fifth harmonic waveform when testing harmonic restraint transformer differential or generator neutral protection relays. When harmonics are present in the fundamental waveform, a harmonic icon will appear in the selected channel(s). See the following figure.



To clear all harmonics either set the harmonic values to zero or press the Clear All Harmonics button.

3.1.12.1.3 **Custom** button: Allows users to customize values displayed by writing a script file.

3.1.12.1.4 **Symmetrical** button: Symmetrical Values, Positive, Negative, and Zero sequence values will be displayed for both voltage and current next to the Vector Test screen, see Fault Calculator button for more information.

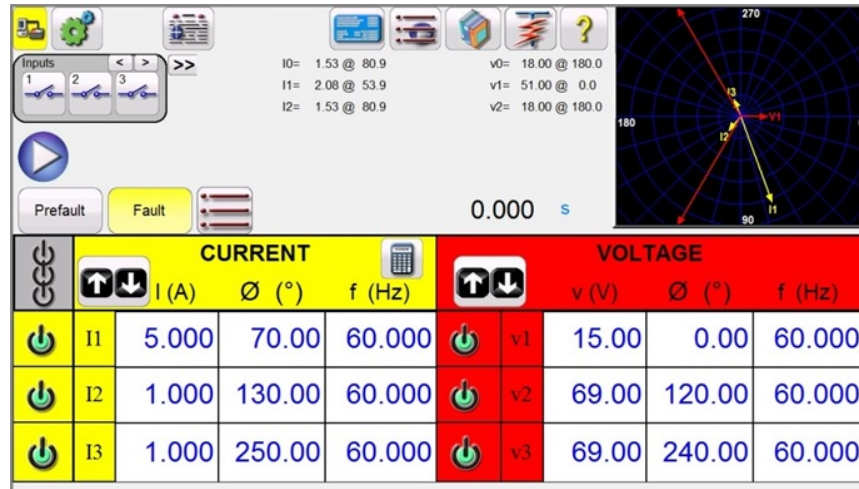

Figure 64 Displayed Symmetrical Values for Phase to Ground Fault

3.1.12.1.5 **Power** button: Power Values, S, P, Q and Power Factor (PF) values will be displayed depending on which channels are selected and what values for voltage, current and phase angles are set.

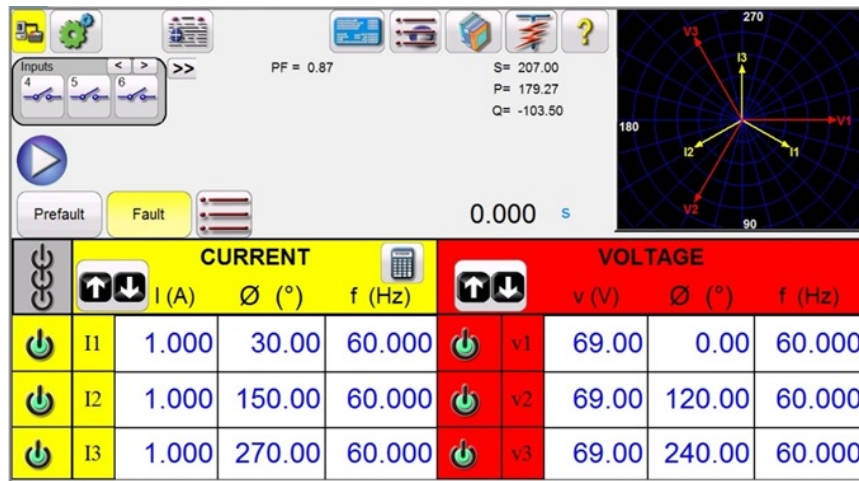

Figure 65 Example for Power Values Displayed

3.1.12.1.6 **Phase to Phase Voltage** button: Phase to Phase Voltage values will be displayed.

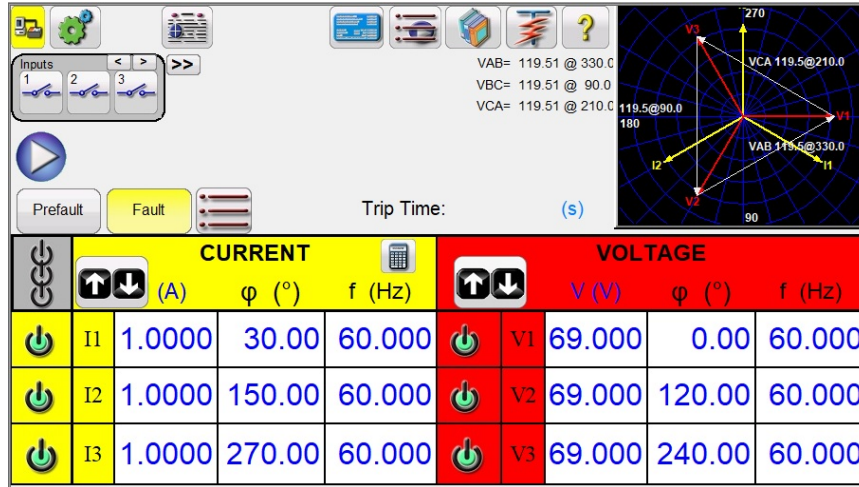

Figure 66 Example for Phase-to-Phase Voltage Values Displayed

Note: If you want the values displayed in the vector screen (as shown above), select Phase to Phase Voltage in the System Configuration screen.

3.1.12.1.7 **Impedance** button: Impedance values will be displayed, see Fault Calculator button for more information.

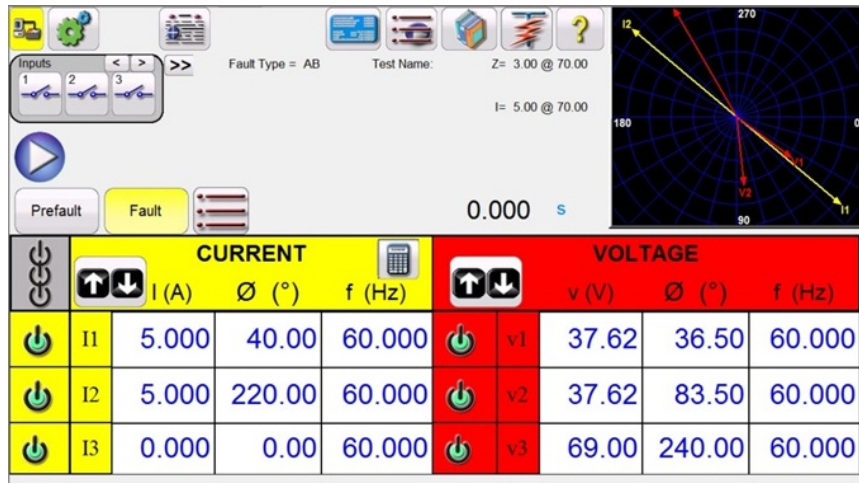

Figure 67 Example for Impedance Values Displayed

3.1.12.1.8 **Secondary Values** button: With CT and PT ratios set in the System Configuration screen, selecting Secondary Values the calculated secondary values being applied will be displayed.

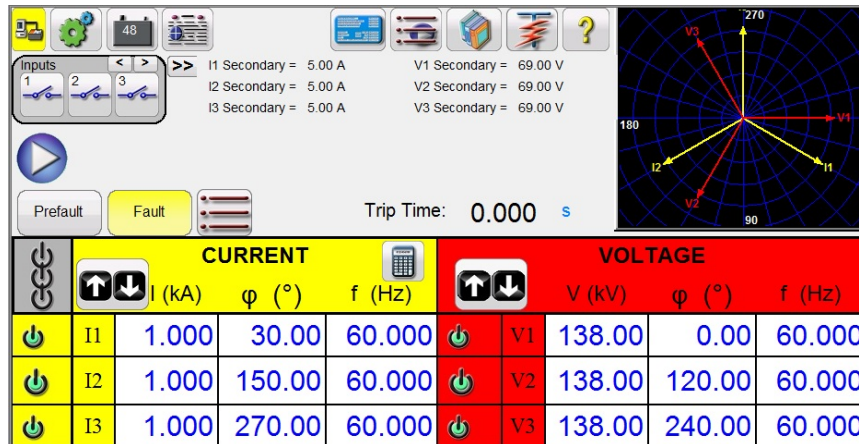

Figure 68 Example for Primary with Secondary Values Displayed

3.1.13

⑬ Maximum Test Time/Prefault Time/Post Fault Time Settings button



Maximum Test Time:  (s)

Prefault Time:  (s)

Post Fault Time:  (ms)

Ramp On (Enabled)  Volts/s:  Amps/s:

Turn off all outputs on test completion: (Enabled)

Pressing this button will present a setting window, which allows the user to enter the amount of time in seconds for Maximum Test Time, Prefault Time and Post Fault Time values that should be applied. In addition, when the Ramp On button is enabled, the user can also set the selected channels to ramp up from the default values to the Prefault values at the selected V/s and A/s. If the Ramp On is enabled, when the timing test is started, the outputs will turn on and start ramping up at the programmed ramp rate. Upon reaching the Prefault values the time window will start counting down starting from the Prefault Time value. When the prefault time has lapsed the Fault values will be applied to the relay under test and the Timer window will start counting until the relay trips. If the Auto off is turned off in the Binary Input (see 3.1.12), the Post Fault Time can be entered with the Enabling of the Turn all outputs off button in this screen. When the relay trips, the Timer will stop and display the operating time of the relay, and the outputs will stay on for the Post Fault Time value entered. If Auto Off is enabled in the Binary Input configuration screen the outputs will turn off immediately after the operation (see 3.1.12 Binary Input Dialog Box section). If the relay has not tripped by the Maximum Test Time setting the test will stop and outputs will turn off automatically.

3.1.14

⑭ Run Test button



Pressing or clicking the blue Run Test button will apply the prefault vector, start the countdown of the Prefault Time setting, then step to the Fault values and look for the relay under test to operate.



### 3.1.15 ⑮ Prefault/Fault buttons

Pressing these buttons will toggle and set the Prefault and Fault amplitudes, phase angles and/or frequencies. If the outputs are on, toggling between the two will apply the prefault and fault values repeatedly with each toggle. This is an especially helpful tool for the user who must adjust mechanical contacts.

### 3.1.16 ⑯ All ON/All OFF button

Pressing or clicking on this button either turns all the selected outputs ON, or if one or more of the outputs are ON, it will turn all the outputs OFF. The center color of this button changes to green when one or more outputs are ON and indicates that pressing the button will turn all outputs off, except for the Battery Simulator. To turn off the Battery Simulator press the Bat SIM button. This button is also used when ramping the battery simulator output.

### 3.1.17 ⑰ Manual Ramp Options button

If using the PC version, the  buttons will be displayed. If using an STVI controller, or if using a SMRT-D series of units, the Control Knob icon  will be displayed. Pressing either of these two will present the user with a window to select the desired level of increment for manually ramping the outputs, the desired channel(s) to be ramped, and what is to be adjusted (amplitude, phase angle or frequency). If using the PC version use the keyboard up down arrow keys (or the mouse wheel) to manually adjust the selected value(s) at the desired increment level. If using the control knob, one click on the Control Knob equals the increment setting. When ramping phase angles, the Up arrow key ramps the phase angle in the counterclockwise direction, and the down arrow key ramps in the clockwise direction. If the Auto Increment button is selected the STVI will automatically select the increment depending on how fast the control knob is being rotated, the faster the rotation the larger the increment.

### 3.1.18 ⑱ Channel ON/OFF Selector button

This button works in junction with the # 16 All ON/OFF button. Pressing this button, the center of the button changes color indicating the output is selected to turn ON. After pressing the All ON button turns the selected outputs on. Pressing the channel button individually turns the selected channels ON and OFF after the All ON/OFF button is ON. This allows the user to turn individual outputs ON and OFF without affecting other channels.

### 3.1.19 ⑲ Fault Calculator button

Pressing or clicking on the selected window will present the user with the Fault Calculator Input Screen.

#### 3.1.19.1 Mode Selection button

Pressing or clicking on the Mode Selection button (upper left-hand corner) reveals a selection list for several types of test options.

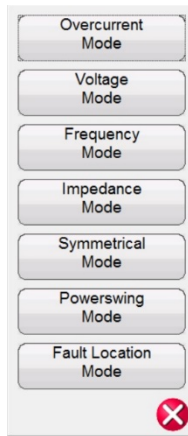

Figure 69 Mode Options

3.1.19.1.1 **Overcurrent Mode** button: The default selection window will present Overcurrent Mode. There are two fields available to enter values, Normal (Prefault) and Fault Values. Enter in the provided windows the desired values of amplitude, and phase angle. Depending on the Selected Fault Type, upon pressing or clicking on the green check mark, the Fault values will appear in the appropriate value windows in the manual test screen. The user can create up to three harmonic current waveforms by entering the desired harmonic from the 2<sup>nd</sup> to the 15<sup>th</sup> harmonic in the windows provided. The harmonic waveform will appear in the window. See the following example.

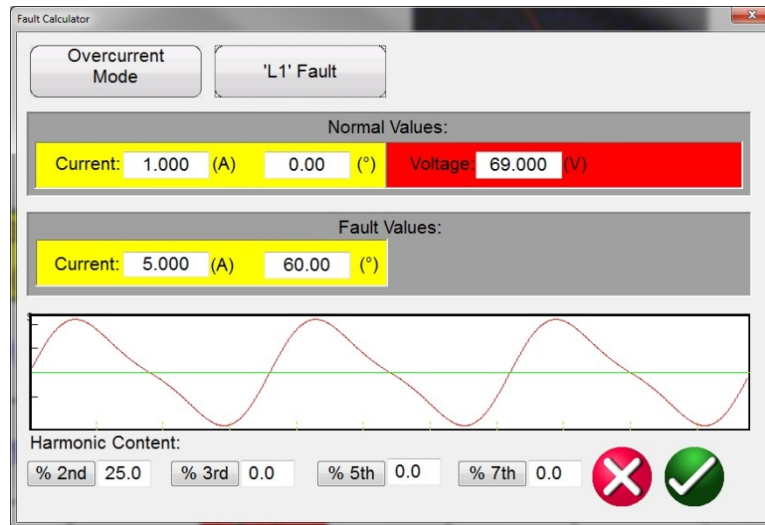

Figure 70 Fault Calculator Harmonic Current Waveform

3.1.19.1.2 **Voltage Mode** button: Press or click on the Voltage Mode button. There are two fields available to enter values, Healthy (Prefault) and Fault Values. Enter in the provided windows the desired values of amplitude, and phase angle (phase angle will be the A phase current relative to the A phase voltage). The user can create up to three harmonic voltage waveforms by entering the desired harmonic from the 2<sup>nd</sup> to the 15<sup>th</sup> and the % harmonic in the windows provided; see example waveform in the above figure for current mode. Depending on the Selected Fault Type, upon pressing or clicking on the green check mark, the Fault values will appear in the appropriate value windows in the manual test screen.

3.1.19.1.3 **Frequency Mode** button: Press or click on the Frequency Mode button. The Fault (Frequency) Values entry window will be provided. Enter the desired fault frequency. The Prefault Frequency will be the default value.

3.1.19.1.4 **Impedance Mode** button: Press or click on the Impedance Mode button. Pressing A Phase to ground fault the user will see the following screen.

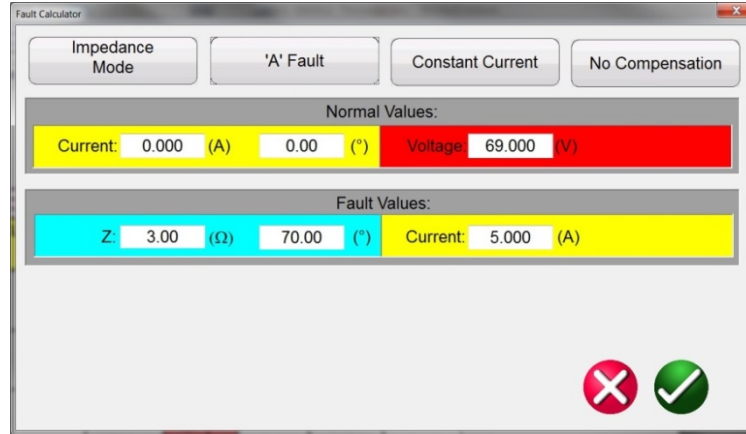

Figure 71 Impedance Mode Input Screen

3.1.19.1.4.1 **Fault Selection** button: Click or press this button to select the desired fault type, phase to ground, phase to phase or three-phase fault.

3.1.19.1.4.2 **Test Model** button: The input screen defaults to Constant Current test mode. In this screen the user simply inputs the Ohmic Reach of the relay, at the desired test angle. If the relay requires Prefault values prior to stepping to the fault values, the user will need to input the desired prefault current and load angle (Normal Values). Click or press the green check button to return to the test screen. Selecting Constant Voltage test mode will present the user with a similar input screen, where the user inputs the desired fault voltage. Selecting Constant Source Impedance, the user will be presented with the following screen.

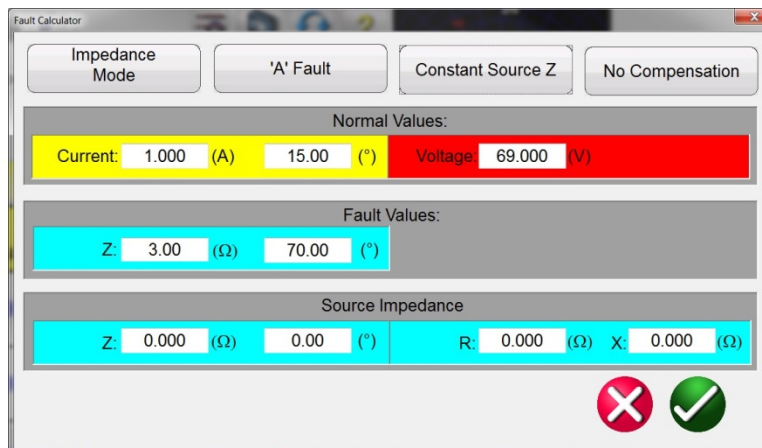

Figure 72 Impedance Mode, Constant Source Impedance

In this screen the user is required to input the source impedance and angle. The fault calculator will calculate the resistive and reactive values based upon the user inputs. Upon returning to the test screen the test values of fault voltage(s), current(s) and angles will be displayed.

**3.1.19.1.4.3 Compensation** button: This button only appears when you select the Phase to Ground Fault type. Press or click on the Compensation Mode button to access the selection menu. There are three types of compensation formulas available, KN, Z0/Z1, and RE/RL XE/XL. Residual compensation factor, KN, is a complex number that is used to express the earth-return impedance, ZN, in terms of the positive-sequence impedance reach setting, Z1. This factor is calculated as:

$$KN = ZN/Z1 = (Z0 - Z1)/(3Z1)$$

Where: Z0 is the zero-sequence impedance polar reach of the zone

**Z0/Z1** Ratio = the complex ratio of Z0/Z1, also referred to as **K0**=Z0/Z1

**RERL XEXL** are a pair of scalar factors. These factors affect the resistive reach and reactive reach, respectively, of some polygon characteristics. They are calculated as follows:

$$RE/RL = (R0/R1 - 1)/3$$

$$XE/XL = (X0/X1 - 1)/3$$

Where:

R1 = real part of Z1

X1 = imaginary part of Z1

R0 = real part of Z0

X0 = imaginary part of Z0

**3.1.19.1.5 Symmetrical Mode** button: Press or click on the Symmetrical Mode button to access the Symmetrical input setting screen. See the following figure.

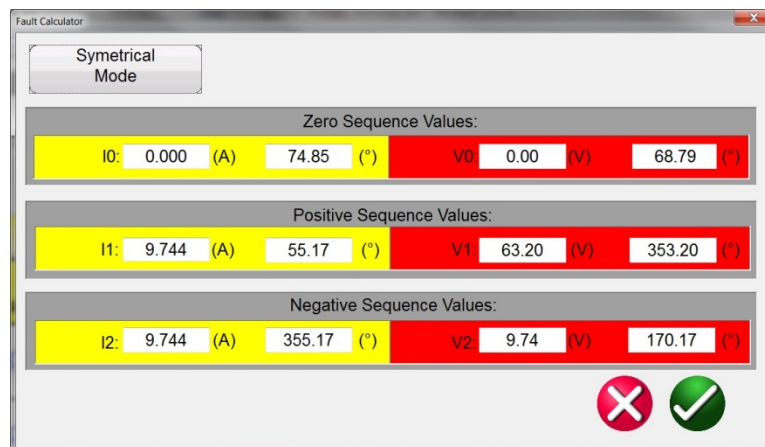

Figure 73 Symmetrical Input Setting Screen

To simulate unbalanced fault conditions, a set of 3-phase unbalanced currents or voltages may be resolved into 3 sets of balanced components of Positive, Negative, and Zero Sequence values. Zero Sequence currents and voltages occur as the result of a Phase to Ground Fault on the system. If testing for Zero Sequence, enter the Zero Sequence Current or Voltage value into the screen above. Upon returning to the test screen, the appropriate Current and/or Voltage values will be displayed and ready for testing. Negative Sequence is a result of a three phase unbalance condition. Enter the

desired negative Sequence values of Voltage and Current and upon returning to the test screen all the three phase values will be calculated and displayed ready for testing.

3.1.19.1.6 **Power Swing Mode** button: Press or click on the Power Swing Mode button to access the Power Swing input setting screen. See the following figure.

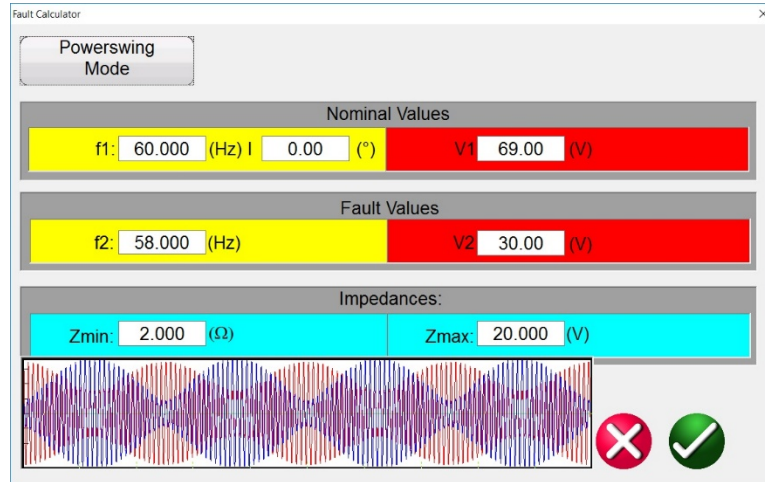

Figure 74 Power Swing Input Setting Screen

The power swing simulation tool uses two superimposing waveforms of similar frequencies to provide a smooth impedance ramp. This method is like a two source model in that both sources have similar frequencies and amplitudes. The rate of change of impedance can be controlled as well as the minimum and maximum impedances, the number of pole slips, as well as the starting phase angle relationships.

The next section will describe the values used to calculate the necessary test values and discuss how to implement a controlled power swing.

To apply a power swing, the following parameters need to be defined.

- The **Maximum Impedance**,  $Z_{max}$ , of the Power Swing needs to be defined. This will be based on the outer most characteristic that is tracking the impedance. It is recommended that the maximum impedance be greater than the largest blinder/characteristic impedance, but not so large that the trajectory of the swing exits the characteristic prematurely.
- The **Minimum Impedance**,  $Z_{min}$ , of the Power Swing also needs to be defined. This will be the minimum impedance point of the swing.
- The **Source Frequencies**,  $f_1$  and  $f_2$ , will determine how long of a duration a single power swing condition will be. The source frequencies will also factor in determining the rate of change of the trajectory of the impedance. The larger the difference in frequency between the two sources, the faster the swing, and the smaller the difference, the slower the swing.
- The **Starting Phase Angle** ( $^{\circ}$ ) needs to be defined so that proper loading conditions can be simulated properly.

Here is how to create a power swing with a **maximum impedance** of 15  $\Omega$ , a **minimum impedance** of 1  $\Omega$ , a Source 1 Frequency ( $f_1$ ) of 60 Hz, a Source 2 Frequency ( $f_2$ ) of 59 Hz, and a starting **Phase Angle** of  $0^{\circ}$ .

The first parameter calculated is how long a complete power swing cycle will take,  $t_{swing}$ . This is calculated using Eq. 1.

$$\text{Eq. 1} \quad t_{swing} = \frac{1}{f_1 - f_2} \text{ (s)}$$

$$\text{Eq. 2} \quad t_{swing} = \frac{1}{60 - 59} = 1 \text{ s}$$

When applying this method to any type of test routine,  $t_{swing}$  should be the maximum time set for how long the swing should be applied. If multiple turns are desired, then maximum time would be the number of turns times  $t_{swing}$ .

A **nominal voltage (V1)** should be defined for the **maximum impedance**, and a **fault voltage (V2)** should be defined for the **minimum impedance**. Take care in choosing a fault voltage because some of the impedances could still be quite large, with large defined as around 15  $\Omega$  or greater. If the fault voltage is too small, negative valued currents would end up being calculated to create the correct conditions. If that is the case, increase the fault voltage until the currents are at an acceptable level. For this example, the nominal voltage,  $V_{nom}$ , is 69 V line-to-ground, and the fault voltage,  $V_{fault}$ , is 30 V line-to-ground.

The value of  $V_{fault}$  can change depending on the impedance and the current required from the test set. The nomenclature of  $V_{fault}$  can also be a little misleading. A power swing event may not necessarily require the extreme values of traditional fault voltages. The swing of impedance may only go from a large value to a slightly smaller value. Such would be the case if the user wanted to swing from 89  $\Omega$  to 50  $\Omega$ . The required fault voltage would not be much less than what was required for starting impedance.

When starting in the pre-fault mode for testing, it is handy to be at the same current level as the starting current for the swing.

The time set for the Pre-Fault duration is critical in that it is necessary for the waveform to end at the precise phase angle and magnitude that is equal to the start of the power swing event. The Pre-Fault phase angle of the current should be equal to the starting phase angle of the power swing. This will also ensure smoothness. In the following figure, the duration was set for 1 s, and the calculated time of 1 power swing was also calculated at 1 s. By setting the Pre-Fault to the same time as the calculated time of the power swing, a smooth transition is guaranteed in the waveforms.

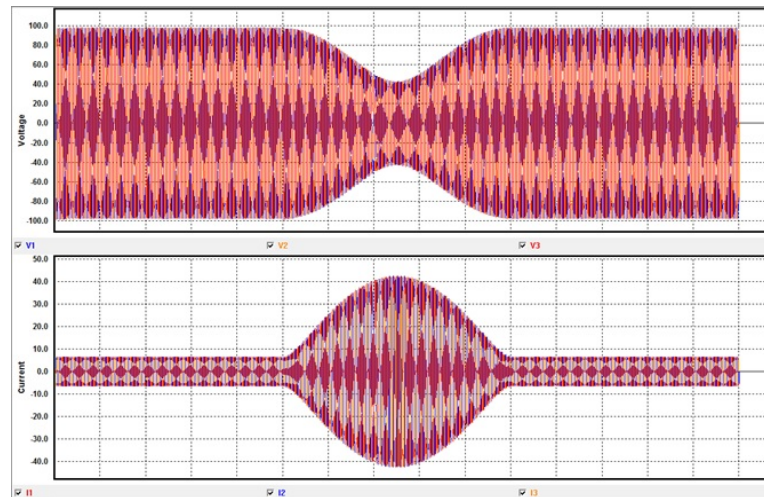

Figure 75 Three Phase Waveform Capture of a Power Swing

The time can also be set to a multiple of the swing duration. In this case, 2, 3, or 4 s would also work. A time of 0.5 s will not work.

3.1.19.1.7 **Fault Location Mode** button: Press or click on the Fault Location Mode button to access the Fault Location input setting screen, see the following figure.

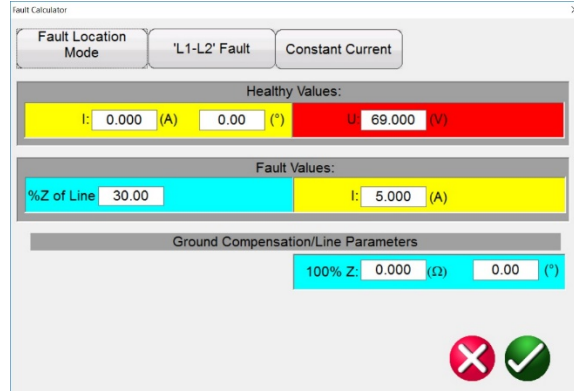

Figure 76 Fault Location Input Screen

Fault Location Mode will allow the user to enter % impedance of a line and the software will calculate the appropriate voltages, currents, and phase angles to replicate the fault at the appropriate location based upon the % entered.

3.1.19.2 Fault Type Selection button

Pressing or clicking on the Fault Type Selection button reveals a selection list for several types of Fault test options.



Figure 77 Fault Types

Users may select Phase to Earth (i.e., A), or Phase to Phase (i.e., AB), or Three Phase fault simulation (i.e., ABC). All values calculated for the type of fault selected will be automatically calculated and entered the appropriate value windows.

### 3.1.20 ⑳ Channel Amplitude, Phase Angle and Frequency buttons

Pressing or clicking on the selected window will present the user with a numeric keypad and dialog box window for setting either individual values or setting multiple values swiftly and easily. For example, to change the default voltage values for all three phases, enter the desired voltage value in the entry window and then press the Balance  button. All the values will change to the desired output voltage. The same is true for both Phase Angle and Frequency.

### 3.2 Setting Phase Angle Relationships

Consider each V/I Generator module as a vector generator. Each module has an internal zero reference to which it references its phase angle settings as displayed on the STVI touch screen or the PC display. This applies to phase angle settings between the voltage and current outputs. When setting a phase angle between two outputs, it is recommended that one output be set at  $0^\circ$  and the other output be referenced to the  $0^\circ$ . This is for operator convenience only. When setting an angle, the operator has a multiple of choices, depending on the Default Phase Angle setting, see 2.3.1.3. In the engineering world and in the following figures, the lagging diagram displays negative rotation and will create negative sequence system components, while the Lead and  $\pm 180$  diagrams display positive rotation which is normal system activity.

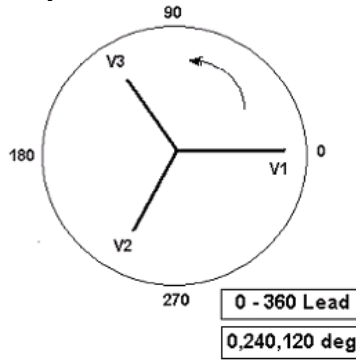

Figure 78 Positive Phase Rotation Diagrams

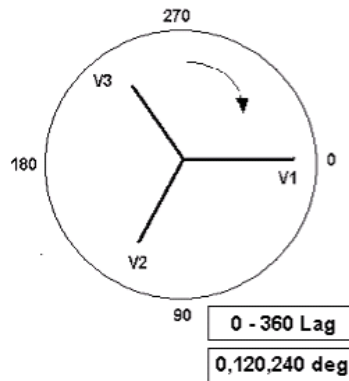

Figure 79 Negative Sequence Phase Rotation Diagrams

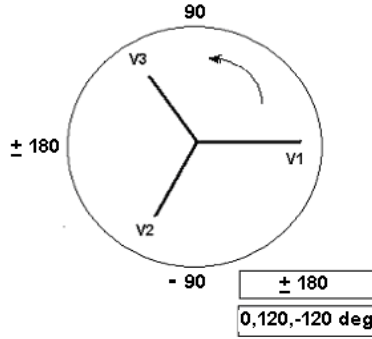
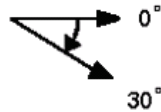
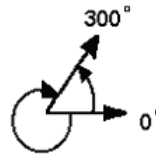

Figure 80 Positive Phase Sequence Rotation Using  $\pm 180^\circ$ .

For example, using 0-360 Lag (0, 120, 240) setting an angle of  $30^\circ$  between the two outputs would look like:



The reference output is  $0^\circ$  and the second output is rotated  $30^\circ$  clockwise. In other words, the angle is lagging the referenced source by  $30^\circ$ . Conversely, if the angle decreases in the counterclockwise direction from  $359.9^\circ$  toward  $0.0^\circ$ , for a setting angle of  $300.0^\circ$ , the second output would look like:



The reference output is  $0^\circ$  and the second output is rotated to  $60^\circ$  in the counterclockwise direction. In other words, the second output lags the reference output by  $300^\circ$  or leads it by  $60^\circ$ . The user may default to phase angles to  $\pm 180^\circ$  with the - (negative) angles lagging and the + (positive) angles leading. Therefore, to set an angle of  $+ 10^\circ$  leading, the vector relationship would be:



### 3.3 Current Sources

#### 3.3.1 Parallel Operation

Each SMRT current amplifier can provide 32 A at 200 VA RMS continuous. For short duration duty cycle the SMRT33/43 units can provide a maximum of 45 A, while the SMRT1, SMRT1D, SMRT36, SMRT36D, SMRT46, SMRT46D, SMRT410, and SMRT410D units can provide up to 60 A at 319 VA RMS per phase for 1.5 s or 90 cycles for testing instantaneous trip elements. When more than 32 A single phase is required for long durations, or more than 60 A for testing instantaneous elements, two or more current channels may be connected in parallel to provide 64 or 96 A continuous (SMRT36, SMRT36D, SMRT46, SMRT46D, SMRT410 and SMRT410D), and up to 120 or 180 A for 1.5 s or 90 cycles.

! Note: If an **F** or **C** appears in the 5<sup>th</sup> digit of the style identification number (i.e., XXXX**F**XXXX) the current returns are floating (isolated from each other and ground). Those units with a style number **G** or **E**, the current returns are common together internally and connected to earth ground.

To parallel the current channels of the unit, perform the following:

If using the sleeved multi-lead current test leads, all the black return leads are interconnected together inside the sleeve so they will all share the return current together. Connect each current channel to the relay under test (both red and black terminals to the load). Each Megger test lead is rated 32 A continuous. If using test leads other than those supplied by Megger, ensure that the wire has sufficient size to carry the test current.

! For the earth grounded common return (G or E) units, there is an internal common ground between the current channel return terminals. If using separate individual test leads, all the return leads will need to be common together at the load as shown in the following figure. By not connecting a return lead to all the current channels in use, part or all the return current will be forced through the internal ground. That means with a 3 channel unit up to 180 A could be forced through the internal common ground and may cause damage to the internal common returns. Therefore, it is important that parallel connections must be made at the relay. See the following figure.

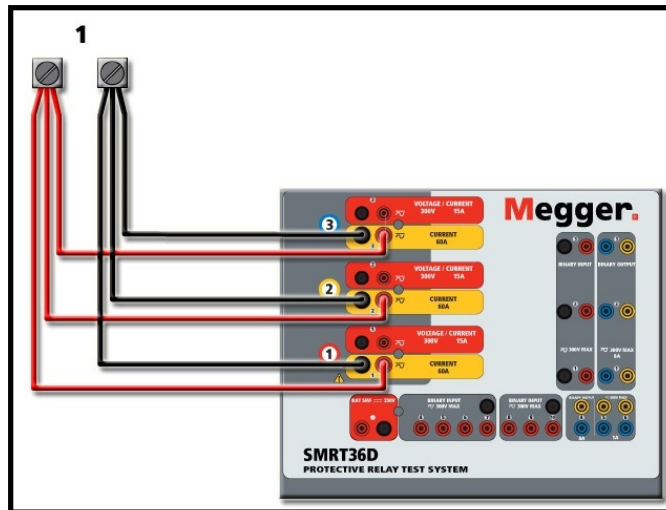

Figure 81 Parallel of Three Current Outputs (SMRT36D)

### 3.3.1.1 Manual Test Screen - Single Phase Up To 180 A

For SMRT46/46D, go to the Configuration screen and select the Operating Mode of 4 **Voltages – 1 Current @ 180 A**. Note for SMRT410, SMRT410D users there is a similar single channel option available. For SMRT users, when you return to the manual test screen there will be one current channel displayed like the one shown in the following figure.

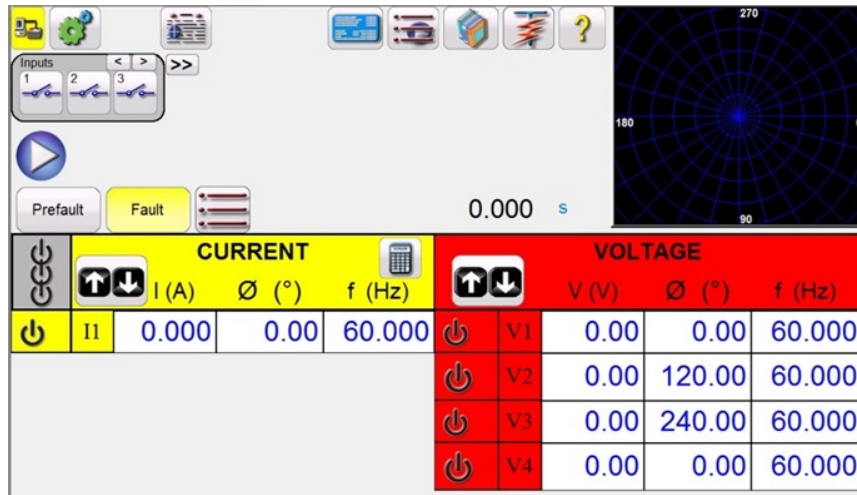

Figure 82 Manual Test Screen – Single Phase High Current Operation

RTMS will automatically set all three currents in phase with each other and divide the current equally between the current amplifiers. When setting an output, simply enter the value of the desired output current. For example, for an output of 75 A, enter 75. If using a SMRT33/43/36/36D/46/46D with 3 current channels, each current amplifier will be providing 25 A. The current can also be phase shifted. Simply enter the desired phase angle and all three currents will be phase shifted together.

If two current channels are to be used in parallel, leave the unit in the default three phase configuration. Connect the two current outputs to the load as shown in the following figure.

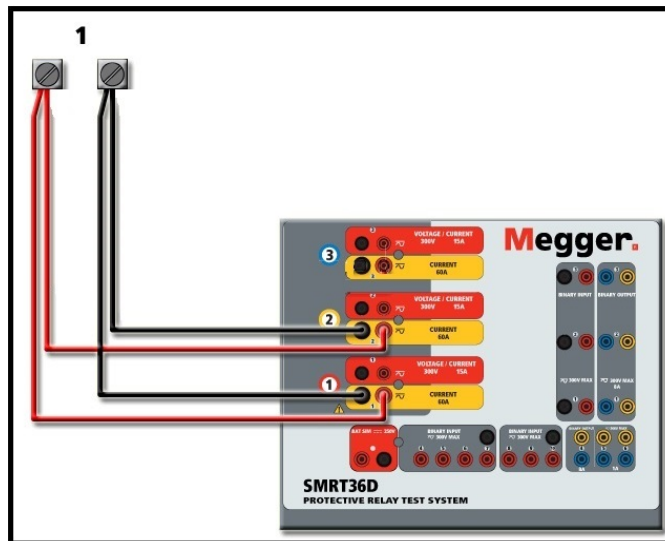



Figure 83 Two Currents in Parallel (on SMRT36D)

Set each channel to one-half of the output requirement. **!** Be sure and **set current channel #2 to 0 degrees** so that it will be in-phase with current channel #1. With both current channels selected, turn output on by pressing or clicking on the ALL ON/OFF button. **Always** use the ALL ON/OFF button to turn both current channels on and off together. For manually ramping outputs, if using the PC version of RTMS the  $\uparrow\downarrow$  buttons will be displayed. If using an STVI controller, or the SMRT-D series of units,

the Control Knob icon  will be displayed. Pressing either of these two will present the user with a window to select the desired level of increment for manually ramping the outputs, the desired channel(s) to be ramped, and what is to be adjusted (amplitude, phase angle or frequency).

### 3.3.2 Currents in Series Operation

Each current amplifier in the SMRT units can produce up to a maximum of 50 V of compliance voltage at test currents up to 4 A. For test currents less than 1 A enable the High Burden Current Amplifier Mode feature in the Configuration screen, see 2.3.1.8. Two current channels may be connected in series to double the available compliance voltage. High impedance electromechanical ground (earth) overcurrent relays have always been difficult to test at high multiples of tap due to the winding impedance and saturation characteristics. The peak voltage required can exceed the maximum output voltage of one SMRT current output channel, depending on the required test current. By connecting two current outputs in series, the compliance voltage is doubled, providing higher test currents through the high impedance load.

There are two methods to series currents together. For the **floating output** (F or C) models connect the two current amplifiers in a “push-push” configuration as shown in the following figure.

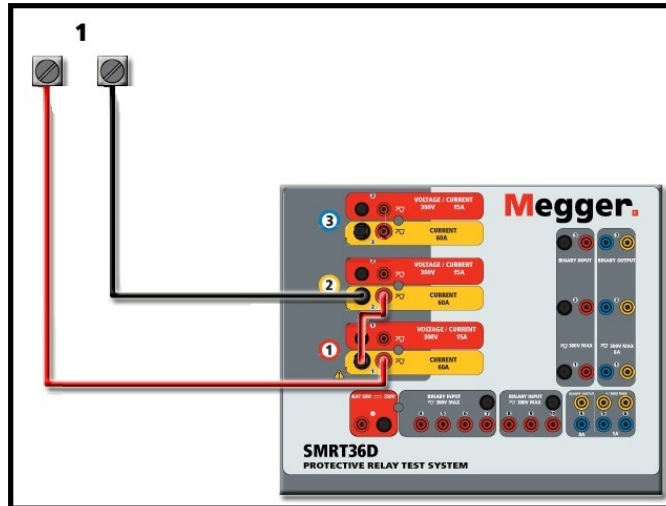



Figure 84 Series Two Currents with SMRT36D Floating Outputs

The two current channels that are to be used in series set each to the same test current magnitude, and phase angle. Select both current channels and turn output on by pressing or clicking on the ALL ON/OFF button. **Always** use the ALL ON/OFF button to turn both current channels on and off together. For manually ramping outputs, if using the PC version of RTMS the  buttons will be displayed. If using an STVI controller, or the SMRT-D, the Control Knob icon  will be displayed. Pressing either of these two will present the user with a window to select the desired level of increment for manually ramping the outputs, the desired channel(s) to be ramped, and what is to be adjusted (amplitude, phase angle or frequency).

To series the current channels of the **common grounded returns** (on the G or E model top cover the black return terminals relate to a black line and the ground symbol), perform the following:

Connect the Red output terminals of the two current channels to the relay under test. Even though the two returns associated with the current channels are connected internally with the common returns,

place a jumper (PN 2001-573) externally as shown. This will ensure that the internal common leads will not be damaged should more than 32 A be applied.

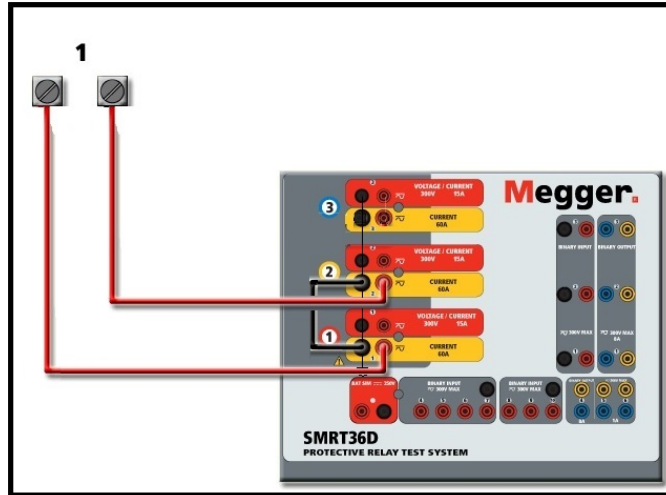



Figure 85 Series of Two Current Channels with SMRT36D Grounded Common Returns

**!** NOTE: One current channel should be set to 0 degrees and the other current channel should be set to a phase angle of 180 degrees so that the two compliance voltages add across the load. **DO NOT** attempt to series more than two currents together on a grounded common returns unit.

The two current channels that are to be used in series set each to the same test current magnitude. Initiate the two current channels simultaneously by pressing the ALL ON/OFF button. **Always** use the ALL ON/OFF button to turn both current channels on and off together. For manually ramping outputs, if using the PC version of RTMS the  $\uparrow\downarrow$  buttons will be displayed. If using an STVI controller, or the

SMRT-D series of units, the Control Knob icon  will be displayed. Pressing either of these two will present the user with a window to select the desired level of increment for manually ramping the outputs, the desired channel(s) to be ramped, and what is to be adjusted (amplitude, phase angle or frequency).

### 3.4 Voltage Sources

#### 3.4.1 Outputs Summed Together

The SMRT voltage amplifiers are all rated for 300 V AC/DC at 150 VA/W. Two voltage channels may be used to sum the voltage outputs to obtain higher than rated voltage provided the load is ungrounded. Connect the load between the voltage channel posts, set  $V_1$  Phase to  $0^\circ$  and set  $V_2$  Phase to  $180^\circ$ . The voltage outputs will add so the total voltage is the sum of the two voltage amplitudes,  $V_1$  and  $V_2$  as can be seen in the following diagram.

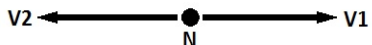

**!** Note: If an **F** or **C** appears in the 5<sup>th</sup> digit of the style identification number (i.e., XXXXFXXXXX) the voltage returns are floating (isolated from each other and ground). Those units with a style number **G** or **E** the voltage returns are common together internally and connected to earth ground.

For the floating common units, the user must connect the associated voltage channels black common returns together, when series operation is required (see the following figures). Remove external commons when testing is completed. **DO NOT** attempt to series more than two voltage channels together since the voltage leads are rated for a maximum of 600 Volts.

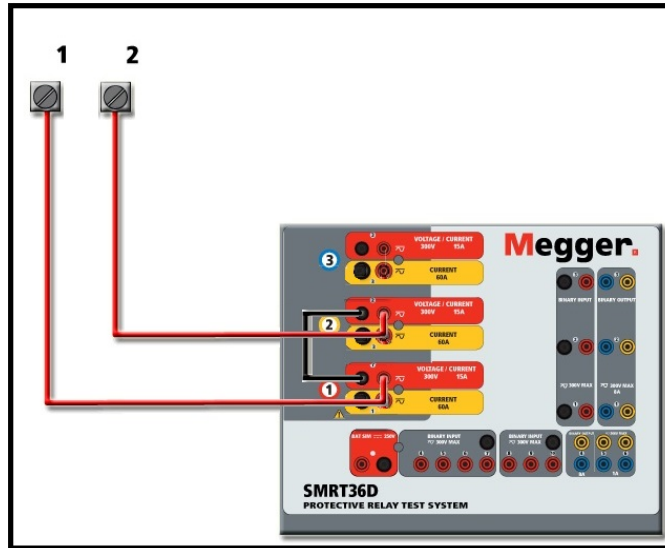

Figure 86 Series of Voltage Channels for SMRT36D Floating Ungrounded Common Returns

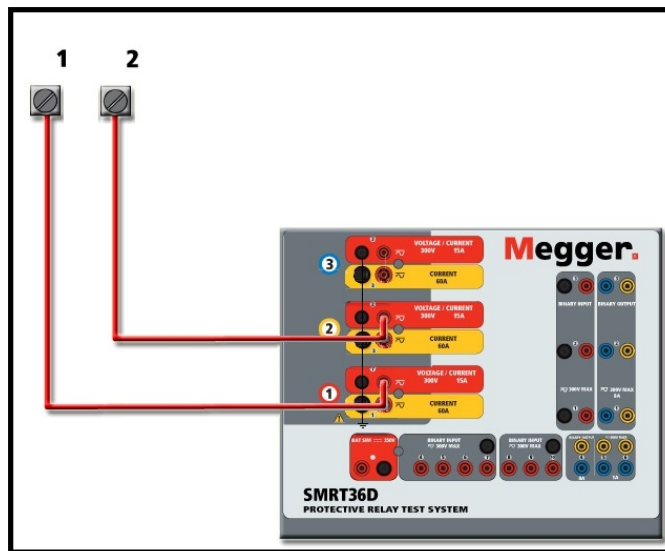

Figure 87 Series of Voltage Channels with SMRT36D Grounded Common Returns

### 3.4.2 3Ø, 3-Wire, Open-Delta, and T-Connection

### 3.4.2.1 Balanced Open Delta

Two methods of obtaining a three-phase, three-wire voltage source are available. The Open-Delta configuration is easier to use when a balanced three-phase source is required because the amplitude and phase relationship can be set directly. No calculations are necessary.

When using the Open-Delta configuration, it is suggested to use voltage channel #1, designated  $V_1$ , and voltage channel #2, designated  $V_2$ , while the COMMON binding post is designated  $V_g$ . With this arrangement, the magnitude and phase angle of the potentials can be easily calculated and set. For the balanced three-phase condition  $V_{1-g}$  and  $V_{2-g}$  are equal in magnitude and separated by an angle of  $60^\circ$ . This is done by setting the  $V_1$  and  $V_2$  potentials equal in magnitude, setting  $0^\circ$  on  $V_1$  and  $300^\circ$  (60 degrees leading assuming that the default phase rotation is set to 360 Lag) on  $V_2$ , see the following figures.

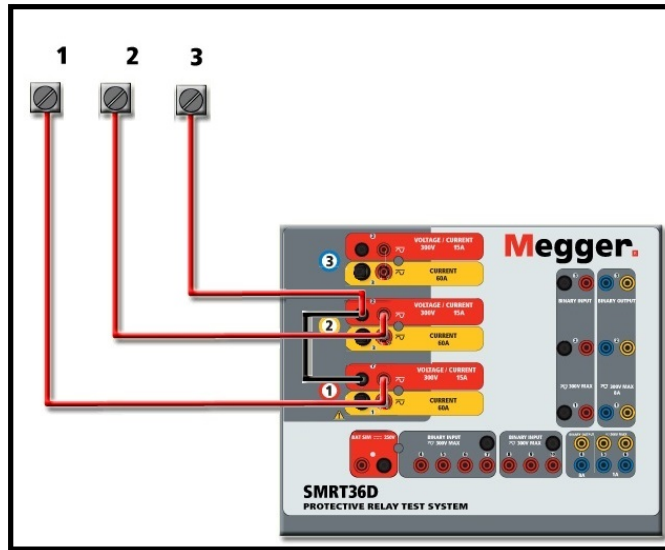
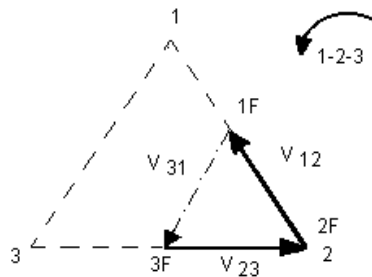

Figure 88 SMRT36D Three Phase Open Delta Connections

When using the Open-Delta Configuration to set up a phase-to-phase fault, calculations using the Law of Cosines is required to calculate amplitude and phase relationships. (See discussion under T-Connection for simulating unbalanced, phase-to-phase faults without need for calculations.)

#### Balanced $3\phi$ - Open Delta Connection



If  $V_f$  equals the desired test potential, then:

Set  $V_1 = V_f \angle 0^\circ$   
 Set  $V_2 = V_f \angle 300^\circ$  (360 Lag configuration)

### 3.4.2.1.1 Unbalanced Open Delta

When setting up an Unbalanced Open-Delta configuration, the desired phase-to-phase fault voltage,  $V_{1f}$  is set using voltage channel #1 with its phase angle set to  $0^\circ$ . Phase-to-phase voltage  $V_{2f}$  and its phase angle relationship for voltage channel #2, must be calculated using the Law of Cosines, where for any triangle the following formula applies:

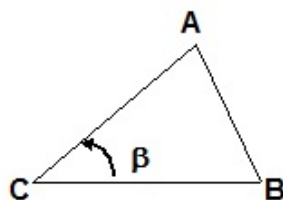

$$AB^2 = AC^2 + BC^2 - 2 \times AC \times BC \times \cos \beta.$$

The next figure shows the phase relationships between voltages and an example of the necessary calculation. For convenience, the amplitude, and the phase angle settings for the typical  $V_f$  fault magnitudes are tabulated.

From the Law of Cosines

$$\theta = \arccos\left(\frac{V_{12}}{2 * V_{23}}\right)$$

$$V_{23}^2 = \left(\frac{V_{12}}{2}\right)^2 + \left(\frac{\sqrt{3}}{2} * V_{12}\right)^2$$

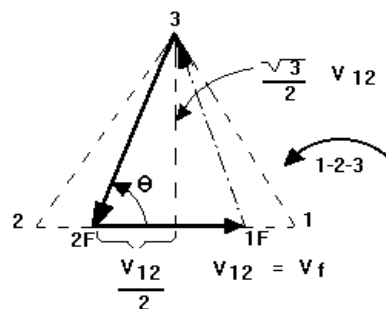

**NORMAL BALANCED CONDITION**  
 $V_{12} = V_{31} = V_{23}$

Settings for Typical Phase-to-Phase Fault Voltages

Figure 89 Open-Delta Unbalanced phase-to-phase Fault Voltages

$$V_{12} = V_f$$

<b>V<sub>12</sub></b>	1	5	10	15	20	25	30	35	40	45	50	55	60	65	70
<b>V<sub>23</sub></b>	104	104	104	104	104	105	105	105	106	106	106	108	108	109	110
<b>At <math>\theta^\circ</math></b>	270	271	273	274	275	277	278	280	281	282	284	285	286	287	289
<b>Lag</b>															

### 3.4.2.2 T Connection

The second method of obtaining a three-phase, three-wire voltage source is the so-called T-Connection. The method, shown in the following figure, is easier to use when obtaining an unbalanced, phase-to-phase fault simulation since it eliminates calculations. To reduce confusion when using the T-Connection, the voltage output #1 is designated  $V_a$  and its phase angle set at  $0^\circ$ , voltage output #2 is designated  $V_b$  and its phase angle set for  $180^\circ$ , and voltage output #3 is designated  $V_c$  and its phase angle is set for  $270^\circ$ . Any combination of balanced three phase faults or unbalanced phase-to-phase fault conditions can be easily simulated. The following figure indicates these phase relationships.

**!** NOTE: This method should not be used for extremely low fault voltages, or used on solid state relays that may be sensitive to this type of connection (i.e., 5 volt or less, or for testing ABB or Westinghouse type SKD relays).

$$V_f = \text{Desired Fault Voltage}$$

$$V_a = \frac{1}{2}V_f \angle 0^\circ$$

$$V_b = \frac{1}{2}V_f \angle 180^\circ$$

$$V_c = \frac{\sqrt{3}}{2} 120 \text{ or } V_c = 104V \angle 270^\circ$$

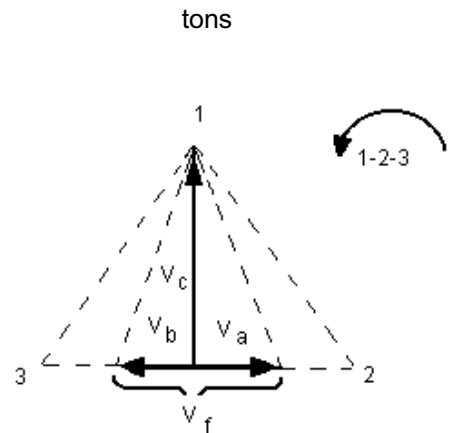

Balanced or Unbalanced Fault T-Connection

### 3.4.3 3Ø, 4-Wire, Y-Connection

A three-phase, four-wire potential system can be provided using three output modules. The vector relationships are referenced below. This Y-Connection has the advantage of being able to supply a higher line-to-line voltage (1.73 x phase-to-neutral voltage). It is ideally suited for simulating phase-to-ground faults. Voltage channel #1 is designated as  $V_a$  with its phase relationship set for  $0^\circ$ . Voltage channel #2 is then designated as  $V_b$  and phase angle set for  $120^\circ$ . Finally, voltage channel #3 is designated  $V_c$  and phase angle set for  $240^\circ$  (for a 1-2-3 counterclockwise rotation).  $V_a$ ,  $V_b$  and  $V_c$  are connected to the voltage potential binding posts on the respective test sets.

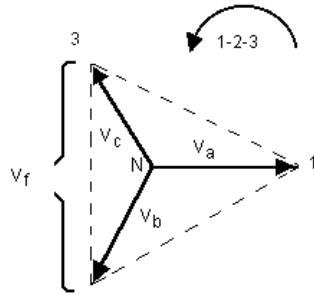

Balanced 3 $\phi$ , 4 Wire Y-Connection

$$V_f = \text{Desired Fault Voltage}$$

$$V_a = \frac{\sqrt{3}}{3} V_f \angle 0^\circ$$

$$V_b = \frac{\sqrt{3}}{3} V_f \angle 120^\circ$$

$$V_c = \frac{\sqrt{3}}{3} V_f \angle 240^\circ$$

**!** Note: If an **F** or **C** appears in the 5<sup>th</sup> digit of the style identification number (i.e., XXXXFXXXXX) the voltage returns are floating (isolated from each other and ground). Those units with a style number **G** or **E** the voltage returns are common together internally and connected to earth ground.

If using the sleeved multi-lead voltage test leads (part number 2001-395), all the black return leads are interconnected together inside the sleeve so they will all share the return together. Therefore, only one return lead is provided on the relay connection side of the sleeved leads (like the connections in the following figure).

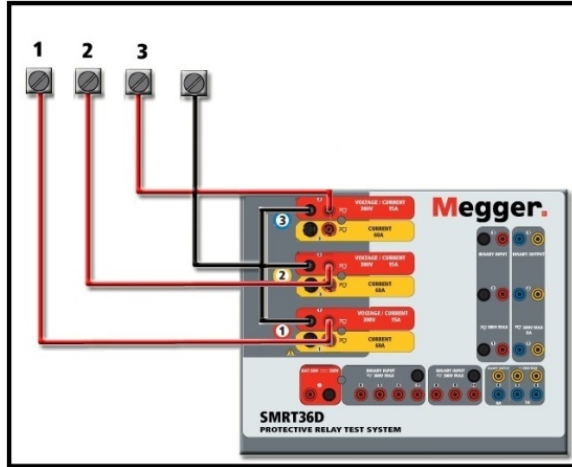

Figure 90 SMRT36D with Floating Returns, Three Phase Four Wire Test Connections

! For the earth grounded common return (G) units, there is an internal common ground between the voltage and current channel return terminals. Therefore, only one return lead is required for the voltage channels. If using separate individual test leads, for the floating common units the user must connect the associated voltage channels black common returns together as shown in the previous figure.

### 3.5 Testing Relays with the Manual Test Screen

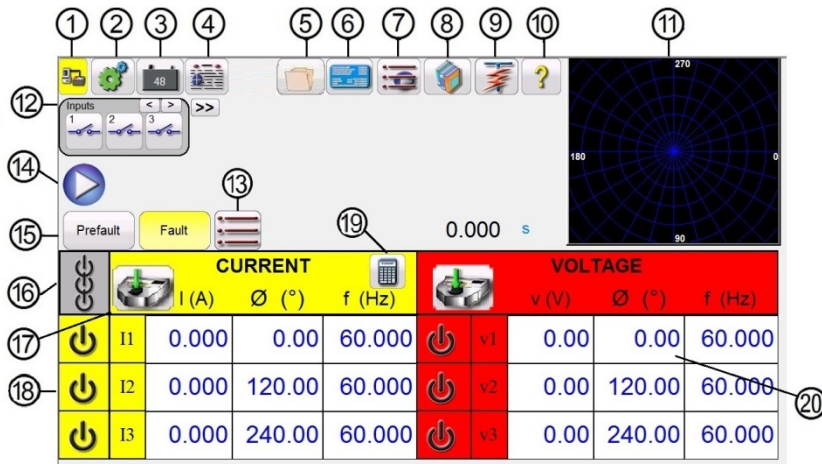

Figure 91 Manual Test Screen

The following tests are examples of how to use RTMS Manual Test Screen for general test applications.

#### 3.5.1 Simple Manual Pickup or Dropout Test



1. Select the channel value(s) to be manually ramped by pressing the appropriate magnitude window(s). Using the numeric keypad as shown in Figure 21, enter the starting value.
2. Connect the appropriate output terminal(s) for the selected channel(s) to be ramped.

3. Connect the desired Binary Input terminal to sense the relay contacts closing or opening. Select the Binary Input ⑫ and set the appropriate sensing Continuity or Voltage modes (see Figure 55A).
4. Press the Output Selector Adjustment icon ⑰, and enter the increment, channel number(s), and whether Amplitude, Phase and Frequency. Note that the selected channel(s) should have a highlighted border around the magnitude window(s).
5. Select the output(s) to be turned on by pressing the ON/OFF icon ⑱ button for the selected channel(s). Upon pressing the ON/OFF button the center will turn green indicating that the channel has been selected to turn on. Turn the selected output(s) on by pressing All ON/OFF button ⑲. When the channel(s) turn on the channel window(s) turns green. Using either the Control Knob, or the PC up and down arrows, manually ramp the output(s) until the relay contacts either picks up or drops out, depending on the start value entered in Step 1.
6. Turn the output(s) off by pressing the ON/OFF icon button(s) or pressing the ALL ON/OFF icon button. By not pressing the ALL ON/OFF button the channel(s) can be turned back on by pressing the channel ON/OFF button again. This provides the ability to toggle outputs on and off to observe contact movement at the pickup threshold.
7. Press the Report options button ④ if you would like to document this test in your report.

### 3.5.2 Simple Manual Timing Test

1. Press the Prefault button ⑮ and set the desired Prefault duration in s in the window provided ⑬.
2. Select the prefault channel(s) to be turned on by pressing the ON/OFF icon button(s) ⑲. Set the Prefault value(s) by pressing the appropriate magnitude window(s), and using the numeric keypad as shown in Figure 21, enter the Prefault value(s).
3. Connect the appropriate output terminal(s) for the selected channel(s) to be used.
4. Connect the desired Binary Input terminal to sense the relay trip contacts.
5. Press the selected Binary Input ⑫, note Binary Input #1 is already set to **Use as Trip (enabled)**. Set for the appropriate sensing Normally Open, Normally Closed, Voltage Applied, or Voltage Removed. If the Binary Input selected is set to monitor mode, Use as Trip (disabled), press or click on the button to change it to **Use as Trip (enabled)**, see Figure 42B, and select Input Type and Input Action as desired. If it is desired to turn the outputs off

when the relay trips press the Auto Off (disabled) button and select the desired channels to turn off.

6. Press the Fault button and set the desired fault value(s) by pressing the appropriate magnitude window(s) and using the numeric keypad.
7. Press the Prefault button returning to the prefault settings. Turn the selected channels on by pressing the ALL ON/OFF . The prefault outputs should now be on. Press the Blue Run Test button . The Prefault countdown timer will start running. The outputs will change from prefault to fault value(s) and the timer will start running. When the relay trips, the Timer will stop indicating the trip time of the relay under test. Once the test has completed all outputs will be turned off if the auto off was enabled. If Auto Off was not enabled the user can input a Maximum Test Time or a Post Fault Time setting, see 3.1.13 Maximum Test Time/Prefault Time/Post Fault Time Settings button, and the outputs will automatically turn off as desired.
8. To save the test result, press the Report options button . The results have now been added to the report and the report is shown. Note that the values are not actually saved to file until you press the File Folder icon and save them as previously defined. The user can now enter appropriate information relative to the test in the Test Report header.



**RELAY TEST REPORT**  
11/1/2022  
PAGE 1  
As Found/As Left



Nameplate Data					
Substation	South 40		Test Status	Pass	
Protection			Job Number	ABC123	
Manufacturer			Current Input	Current Transformer	
Model			Voltage Input	Potential Transformer	
Asset ID			CT Ratio	1000 A : 1 A	Earthing L->N
Serial Number			PT Ratio	1000 V : 1 V	
Relay Firmware			Rotation	Counter Clockwise Rotation 0-360 Lag	

  

Timing Test						
Prefault Time(s)	Operation Time		Measured (s)	Minimum Value (s)	Maximum Value (s)	✓/X
0.000			1.517	1.500	1.600	✓

Channel	Prefault			Fault		
	Magnitude	∅ (°)	f (Hz)	Magnitude	∅ (°)	f (Hz)
Current A-N	0.0000 A	0.00 °	60.00 Hz	5.0000 A	0.00 °	60.00 Hz

Figure 92 Example PowerDB Report

If using the STVI, or the SMRT-D units, use the **Control Knob** to scroll up and down to view all results. Note that there is a space in the upper right corner for company logos to provide a finished and professional look (see Configuration Screen). Also, note the Options  button just above the recorded results. Pressing this button, the user will be presented with several choices for the recorded results.

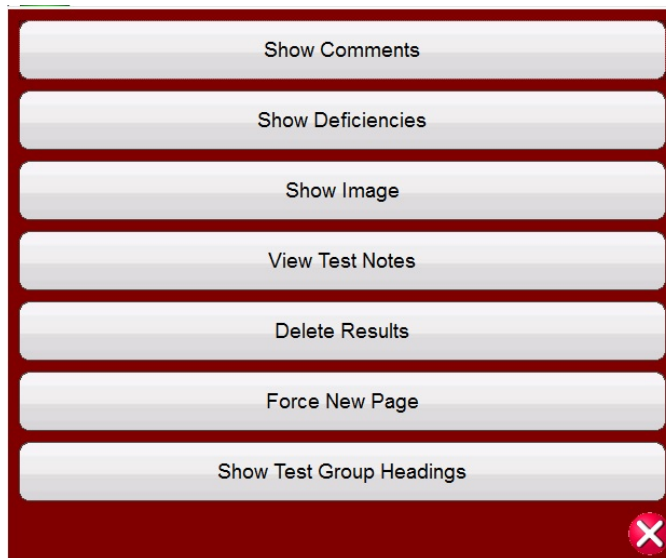





Figure 93 Report Options Screen

The results can be moved up or down to change the order of the results presentation. The result can be deleted, or a retest performed by pushing the blue Run Test button. In addition, the user can add or hide Comments or Deficiencies. Press either Close report to return to the test screen or press Cancel to return to the report. To exit the report, press the Check button in the top left corner or select the Options button followed by the 'Close Report' button.

### 3.5.3 Simple Ramp Test

The Ramp Test feature of RTMS may be used to automatically determine pickup or dropout of several types of relays. Press the Select New Test button  to get access to the Ramp Test screens. The first option  is the Simple Ramp test. After selecting Simple Ramp, if you want Advanced Ramp instead of Simple Ramp press or click on the more  button and select Show Advanced Ramp.

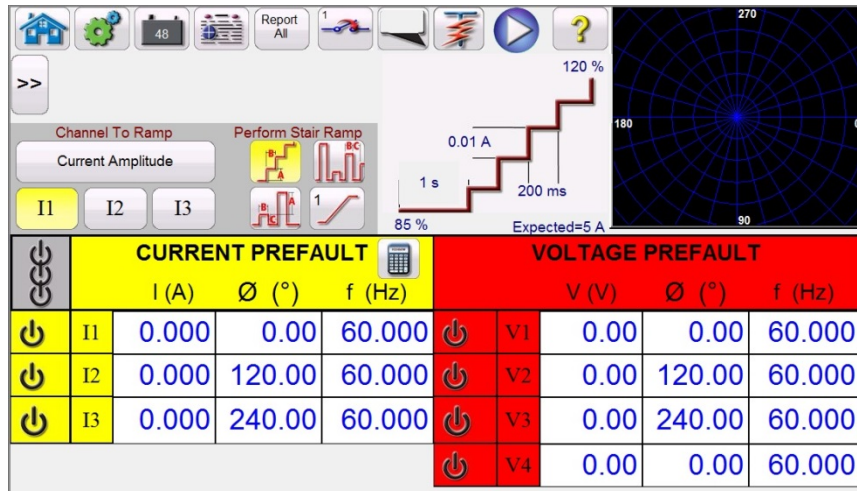

Figure 94 Simple Ramp Test Screen

There are three added buttons across the tool bar. The **Report All** button will include all ramps in the report. If not enabled, it will only record the last pick up or drop out value. The Binary Input button will open to the Binary Input dialog box; see 3.1.12 Binary Input Dialog Box for setting descriptions. The Show/Edit Pretest notes button allows the user to view or edit test notes.

In the **Channel to Ramp** the user may select what is to be ramped. The screen defaults to Ramp Current Amplitude. Pressing this button provides the user with eight different options.



Figure 95 Value to be Ramp Selection Screen

The user may select voltage or current, Amplitude, Phase, Frequency or Symmetrical values. The channels selection directly under the Channel to Ramp button allows the user to select which channels will be ramped.

Once a value is selected to ramp the user must then choose which type of ramp (there are three to choose from).



Figure 96 Simple Ramp Options

### 3.5.3.1 Configuring of Multiple Ramps

Multiple ramps may be performed to provide a finer resolution of the pickup or drop out value, by ramping up or down in large increments, then changing to a smaller increment on the second or third ramp. This is done by clicking on the Multiple Ramp  button. Up to 24 ramps can be performed for any pickup or drop out value. In this example a double ramp will be programmed. Ramp 1 will use the default starting value of 85% of the Expected value. For this example, the output current will be ramped up in 0.1 A increments in the first ramp. The second ramp will start when the monitored contacts close (Normally Open to Close). For the start of the second ramp the user will need to click on the Multiple Ramp button and select Set # Ramps and select 2. To set the new starting value click on the 85% Start Value displayed in the test screen. A numeric keypad will appear with the lower bar labeled Start is Value (meaning the start value will be 85% of the Expected value. Click on the bar to see a list of start options, see the following figure.



Figure 97 List of Start Value Options

**Start Value** would be the same as the original Start Value, or 85% of Expected Value. **Start is % Last Value** would start at 85% of the last value where the monitored contacts closed. For this example, let us say the contacts closed at 5.5 A. Therefore, the next start value would be 85% of 5.5 A, or 4.675 A. If this is an electromechanical relay, this would cause the contacts to open slightly before the second ramp starts. To get a finer resolution, the user could select a smaller increment for the second ramp by clicking on the increment value, and thus start the second ramp with smaller increments. **Start is Last Value** the second ramp will start at where the contacts close. This could be used to find the dropout, or ramp down until the contacts just open and then back up at a smaller increment to find the pickup with higher resolution.

### 3.5.3.2 Stair Step Ramp Example

The first selection ① is the Stair Step Ramp which will ramp the output by applying a value and then waiting a specific amount of time before incrementing it. Depending on what is being ramped the user must enter the Expected value of pickup by pressing or clicking on the **Expected** value as shown in the following figure. For example, to automatically ramp output current the user will, input **Expected** Amplitude(s), an Increment (A), and a Delay time in ms (B). Three other values are also adjustable by the user. The start value, defaults to 85% of the Expected pickup value. The prefault duration defaults to 1 s. The stop value defaults to 120% of the Expected pickup value. To change any value simply touch or click on the value.

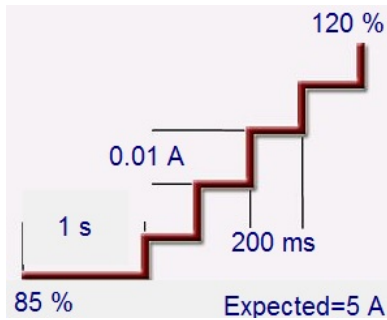

Figure 98 Stair Step Ramp Setting Example

In the above example, 5 A was set as the **Expected** pickup value, with an Increment of 0.01 A (A) and a Delay (B) time of two hundred ms between each increment. To start the auto ramp, push the blue Run Test button. The prefault current will start at 4.25 A (85% of 5 A) and applied for 1 s before the ramping starts.

### 3.5.3.3 Pulse Ramp Example

The second selection ② is for Pulse Ramp and will ramp the output, returning to the prefault condition between each increment.

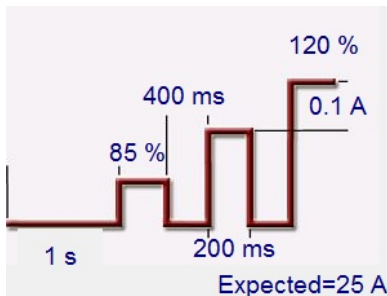



Figure 99 Pulse Ramp Setting Example

First, set the desired prefault value in the appropriate window, i.e., load current. In the example above, the **Expected** pick up value is 25 A. The Increment value is set to 0.1 A. There are two different time setting values, Dwell time and Pulse time. The Pulse time is the time that the incremented value is applied before going back to the prefault vector state. In the above example, the value is two hundred ms. The output will then stay at the prefault value for the Dwell time, shown as four hundred ms above, before progressing to the next increment level until the relay operates. Press or click on the '1 Ramp'  button. This allows the user to select the number of cascaded ramps to be performed. A common use for 2 ramps would be to set the increment level in large steps and then when the relay picks up reduce the output by a percentage of the pickup value. Ramping can then start, but at smaller increments until the relay picks up again, thus providing a finer resolution on the actual pickup point. This feature is used when doing instantaneous pickup tests. The output current, or voltage, can be incremented in large steps getting to the pickup point quickly. This reduces the test time, heating of the relay under test, and provides a perfectly accurate test result. This feature is also used when testing multi zone distance relays using three phase voltage and currents. Set the Pulse duration just long enough for the intended zone to operate. If you are not sure exactly where the pickup value of the relay is, you can use the Pulse Ramp Binary Search ③ feature.

### 3.5.3.4 Pulse Ramp Binary Search Example

The third selection ③ on the tool bar is Pulse Ramp Binary Search. The Pulse Ramp Binary Search is used to quickly determine the pickup value of a relay with a questionable or unknown set point or operating characteristic. More importantly, this feature is excellent for testing relays, which require a pre-fault condition prior to sensing a fault condition.

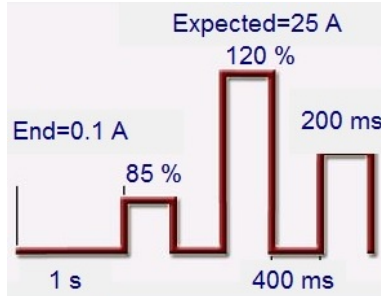

Figure 100 Pulse Ramp Binary Search Setting Example

The setting values are the same as the Pulse Ramp. However, instead of Increment value, the user defines the **End** Resolution of the final search increment. On execution, the control will incrementally search for the relay pickup starting with Prefault Value(s). The first output will be the Prefault setting(s), then pulsing to the Fault value(s). If an operation by the relay occurs within the Pulse Time, the Fault value(s) output will automatically increment down by 50% of the difference between the last operate and no-operate point. Like Pulse Ramp, the output toggles back and forth between the Prefault and the next Fault value(s). The bi-directional pickup and non-pickup operation keeps dividing back and forth very quickly until the End Resolution is reached. Once the end resolution is reached the final pickup value(s) will be displayed.

### 3.5.3.5 EM (Electromechanical) Overcurrent Pickup Example

This example will use three stair step ramps to determine the trip contact pickup point of an electromechanical overcurrent relay. The example relay has a tap setting of 5 A. The Time Dial is set somewhere in the middle, and the trip contacts are Normally Open.

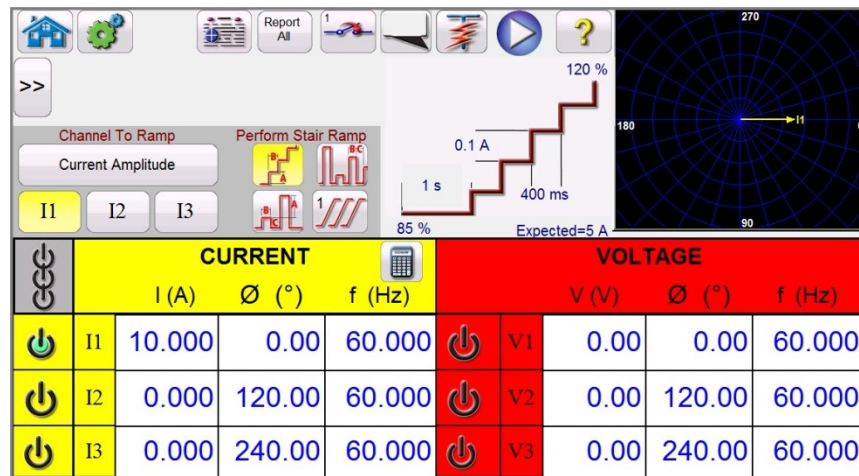

Figure 101 EM Overcurrent Pickup Example

Note that in the example above, current channel I1 is selected, and set to value of 10 A. A stair step ramp is selected, with three ramps.

The basic operation of the test is that the test set will apply twice (10 A) of the **Expected** value of 5 A for a predefault duration of 1 s. This will allow the EM disk to turn and close the trip contacts. A longer predefault duration might be required depending on the Time Dial setting. The test current will be dropped by a percentage (using the default setting of **85%**) of the expected value before ramping starts. This will cause the trip contacts to open, and the ramp up will start at a test current of 4.25 A ( $85\% * 5 \text{ A}$ ). Binary Input #1 is programmed for Normally Open contacts to close. The increment is set to 0.1 A, with a delay between steps of four hundred ms.

The second ramp is programmed as follows.

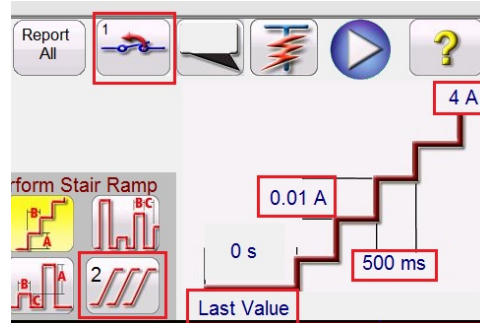

Figure 102 Second Ramp Settings

With the trip contacts closed it should be at a pickup value slightly greater than the **Expected** value of 5 A. The second ramp is programmed to start ramping at the **Last Value**. It is programmed to start ramping down towards **4 A** as shown in the figure above. The increment for the second ramp is set to a value of **0.01 A** at a delay of **five hundred ms** between increments. Binary Input #1 is programmed to look for the trip contacts to open. With a smaller increment and longer delay between steps the trip contacts will open before the third and final ramp begins.

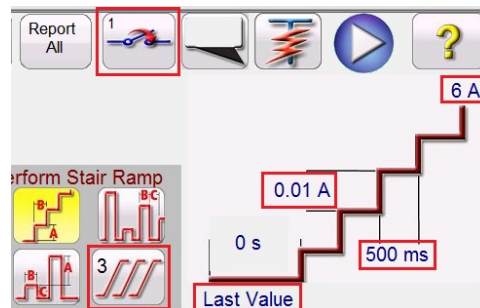

Figure 103 Third Ramp Settings

The third ramp is programmed to start ramping at the **Last Value** (where the contacts just opened). It is programmed to start ramping up towards **6 A** as shown in the figure above. The increment for the third ramp is set to a value of **0.01 A** at a delay of **five hundred ms** between increments. Binary Input #1 is programmed to look for the trip contacts to close. When the relay trips the software will stop the ramp, turn the output off and report the pickup value. The user will have the option to Add to the Report.

### 3.5.3.6 Instantaneous Pickup Example

This example will use a pulse ramp to determine the trip contact pickup point of an instantaneous overcurrent relay. The example relay has a tap setting of 25 A, and the trip contacts are Normally Open.

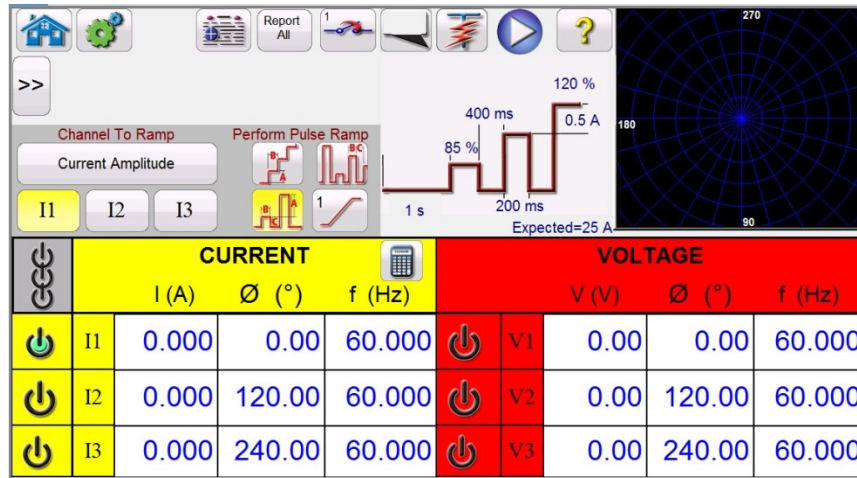



Figure 104 Instantaneous Pickup Example

The basic operation will apply a percentage (using the default setting of **85%**) of the **Expected** value when ramping starts (for the above example 21.25 A). The increment is set to 0.5 A, with a delay between steps of four hundred ms between pulses, with the fault current applied for two hundred ms duration. For relays with programmed delay associated with the instantaneous setting, the pulse duration time may need to be adjusted from the default of two hundred ms. In this example 0.5 A is 2% of 25 A, which should be acceptable in terms of resolution and accuracy. If a higher resolution or accuracy is required, then set the increment level to a smaller value. When the test starts the initial test current of 21.25 A will be applied and the binary contacts should not be closed. The test current will drop back to 0 A, then increment up again. It is important to note that the test current is returned to zero. If the device under test is an electromechanical “clapper” device, you want the moving element to drop back to its original position before applying the next incremented value. When the relay trips the software will stop the ramp, turn the output off and report the pickup value. The user will have the option to Add to the Report.

### 3.5.4 Advanced Ramp Test

After selecting Advanced Ramp, if you want Simple Ramp instead of Advanced Ramp press or click on the more  button and select Show Simple Ramp.

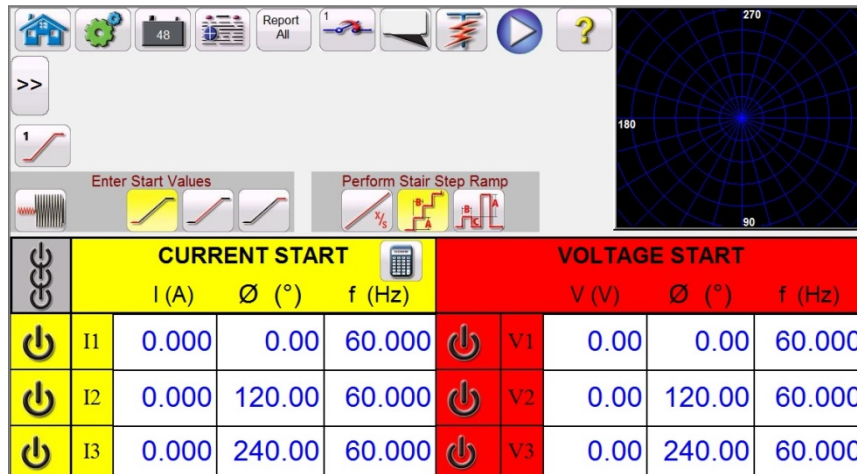

Figure 105 Advanced Ramp Test Screen

Advanced Ramp has similarities to the Simple Ramp. The primary differences are the Start, Increment, Stop values, and the addition of the Smooth Ramp.

### 3.5.4.1 Setting Values

Pre-Fault, Ramp Start, Ramp Increment, and Ramp Stop values are entered by clicking on the appropriate button as shown in the following figure.



Figure 106 Advanced Ramp Settings

#### 3.5.4.1.1 Show Pre-fault Conditions button

Press this button to select and enter the appropriate pre-fault values, including the Pre-fault Time (the time that the pre-fault values will be applied prior to starting the ramp).

#### 3.5.4.1.2 Show Ramp Start button

Press this button to select and enter the appropriate start ramp values. This value is where the ramping will start, which can be different from the Pre-fault values.

#### 3.5.4.1.3 Show Ramp Increment button

Press this button to select and enter the appropriate ramp increment values. If the smooth ramp is selected, the increments will be x/s, or increment/s as shown in the test screen as CURRENT/s or VOLTAGE/s. If the Stair Step or Pulse Ramp are selected it will read CURRENT INCREMENT or VOLTAGE INCREMENT.





#### 3.5.4.1.4 Show Ramp End button

Press this button to enter the appropriate stop ramp values. This value is where the ramping would stop, regardless of whether the relay operated or not.

#### 3.5.4.2 Smooth Ramp

The Smooth Ramp will ramp up the output by applying a value based upon entry of an increment value/s. Depending on what is being ramped (Amplitude, Phase, or Frequency) the user must define the Start and Stop values being ramped. For example, to automatically ramp output current the user will, input Start and Stop Amplitudes, and an Increment A/s. Based upon the Start, Stop, and Increment/s settings, the software will automatically ramp values of the selected output which will result in a smooth ramp from the Start point to the Stop point.

### 3.5.5 Ramping Battery Simulator Output

1. On the STVI display screen press the  Manual Ramp Options button. In Channel Increment Selection Screen press or click on the Battery button. Select the desired increment level of the Battery Simulator, 1 or 5 V increments. Press on the green check button.
2. Upon returning to the main test screen, note the Battery Simulator will be set for the value setting in the configuration screen. If another starting value is desired, go to the configuration  screen and enter the starting value in the window provided, and press the green check button. For manual ramping press the  All ON/OFF button, note button turns green.
3. Press the battery  button and note that it changes to red indicating that the battery output is on, and it will have a yellow arrow through the box  with the dc starting value to be ramped. Use the control knob (pc version use the cursor up down arrows or mouse control wheel) to vary the dc voltage output (clockwise increases the output). One click will equal the increment setting. To turn the battery simulator off, press the battery button. Note: If you have completed the test press the All ON/OFF button. Once the All ON/OFF button is off, the battery simulator can be turned on and off by pressing the battery button, but it cannot be varied.

### 3.5.6 Overcurrent Tests

Pressing the Overcurrent Timing button  will go to the Relay Elements and Tolerance Setup Screen,

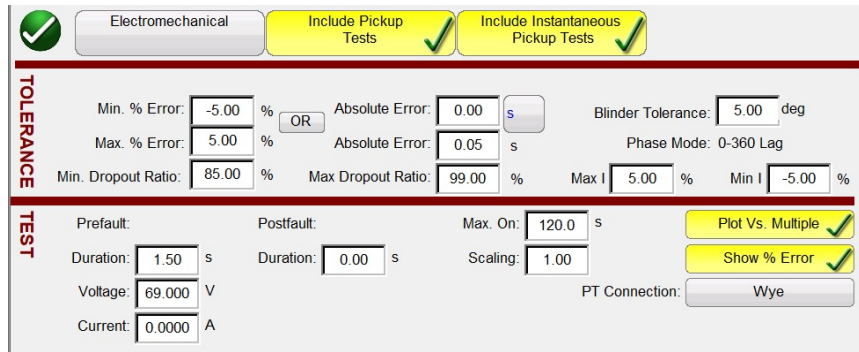

Figure 107 Relay Tolerance Setup Screen

The user will see three buttons on top of screen:

1. Electromechanical
2. Include Pickup Tests
3. Include Instantaneous Pickup Tests

The user can check one, two or all buttons or uncheck them to add or not to add the respective test button to the List of Tests to Run.



Figure 108 Test Selection Buttons

When Electromechanical Button is checked, Include Target and Seal-In Tests Button will appear and is available to be checked or leave it unchecked. If checked it provides the user with the appropriate outputs necessary (typically 0.2, or 2 A) to do a pickup and dropout test on an electromechanical overcurrent DC Target and Seal In relay.

**[i]** Application Note: It is difficult to monitor the seal in contacts, therefore, it is up to the user to observe the contacts and press the SIM button when the seal in contacts close or opens.

#### TOLERANCE Window

The user needs to enter the Manufacturer's Tolerance Specifications, which are found in the relay's user guide. The **Absolute Error** can be written in Seconds (s) or Cycles (Cy) by pressing on the  button.

#### TEST window.

The user needs to define the following:

**Prefault Duration:** Time duration for application of Prefault values.

**Prefault Voltage Current Levels:** Enter the appropriate voltage and current levels.

**Postfault Duration:** Amount of time the fault current will be applied after sensing trip (for relays with breaker failure sensing).

**Max On:** Time the test will be performed (the maximum time the fault current will be applied)

**Scaling:** Used to scale instantaneous currents greater than 60 A (for SMRT). As an example, if the instantaneous setting is 75 A, setting the scaling to two will result in a message appearing to parallel current channels 1 and 2 together. The test current will be divided equally between the two currents.

Multiples of Tap. Pressing the button will result in the graphic changing to Time vs. Current.

**Show % Error:** When checked the timing results will display with % error.

**PT Connection:** For voltage restrained overcurrent, enter Wye and Open Delta

Once Tolerance and Test data are completed, pressing the green circle check button will take the user to the Elements setting window as shown below.

**ELEMENTS** window.

The user needs to define the Elements of the protective relay to be tested. The screen Defaults with Phase and Ground. Pressing the Number of Elements button will provide the user with the ability to add up to 24 Elements.

In the following example, two Elements were added, E2 and E3. In the E2 example, the Phase-to-Phase elements (A-B, B-C, C-A) were selected.

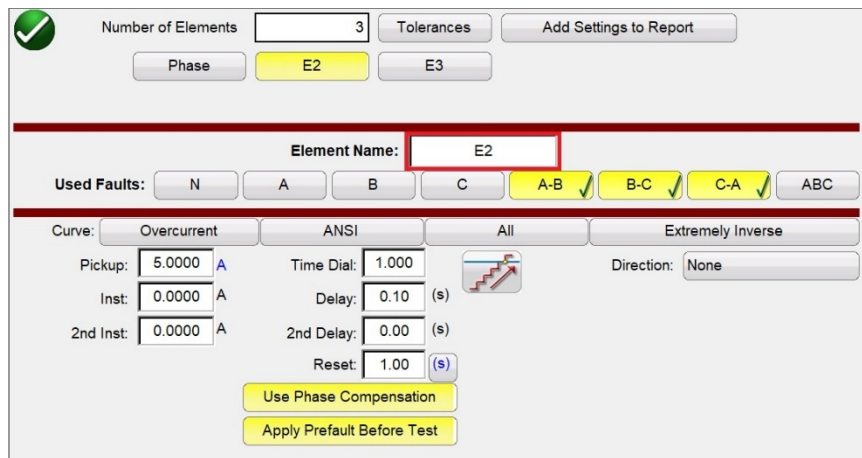

Figure 109 Selecting and Defining Multiple Elements

Note the Element Name can be changed by clicking in the window highlighted in red, and a virtual keyboard will appear. Changing the name in the provided window will rename the Element button, see the following 3 Phase example.

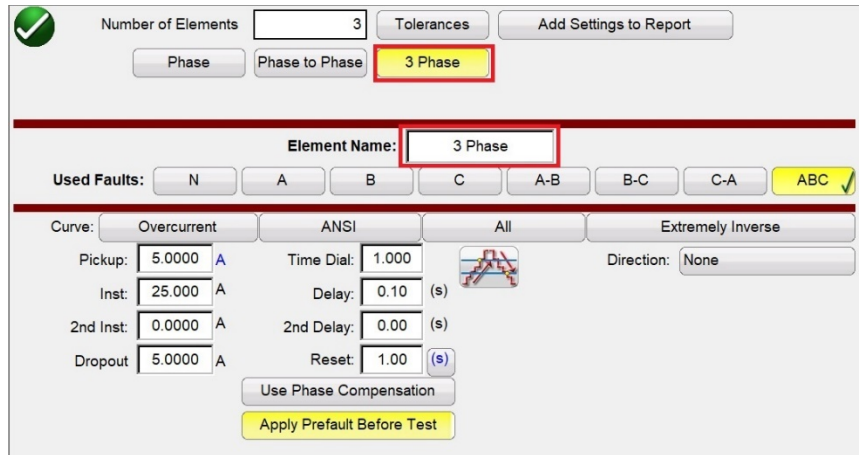



Figure 110 Phase Setting Screen

First, it should be noted that the Phase to Phase and 3 Phase Element buttons in our previous examples have been added to the row next to Phase button. Therefore, any Elements added will appear here to enter settings. Selecting the double ramp  will open the Dropout value window as shown in the above example. Therefore, when performing the Phase Pickup test, both pickup and dropout tests will be performed.

### 3.5.6.1 Curve Selection Button

Pressing the default ANSI/IEC curve button will provide access to all the overcurrent time curves. Curves include ANSI, IEC, and IEEE Standard time curves as well specific Relay Manufacturers.



Figure 111 Time Curve Selection Screen

### 3.5.6.1.1 Manufacturer's Model Button

Selecting a manufacturer will provide access to all models available for that manufacturer.



Figure 112 Relay Model by Brand Selection Screen

### 3.5.6.1.2 Relay's Curve and Direction per Element – Selection and Configuration

Press **Definite Time** to select the appropriate time curve for the relay under test.

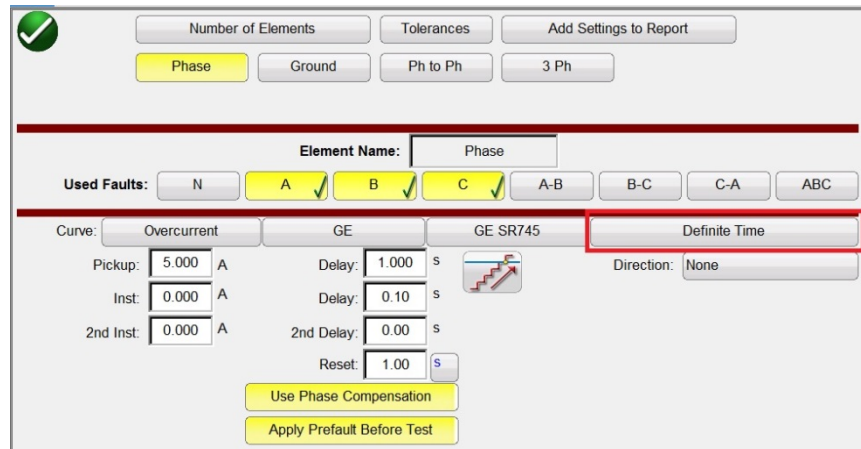

Figure 113 Curve Button location (Red boxed) for the GE SR745 Phase Screen



Figure 114 Available Curves List (Options depends on previously selected relay)

Press **Direction** Button in Relay Settings Screen to select the element of protection, namely Directional (Forward or Reverse) and Bidirectional depending on type of relay under test.

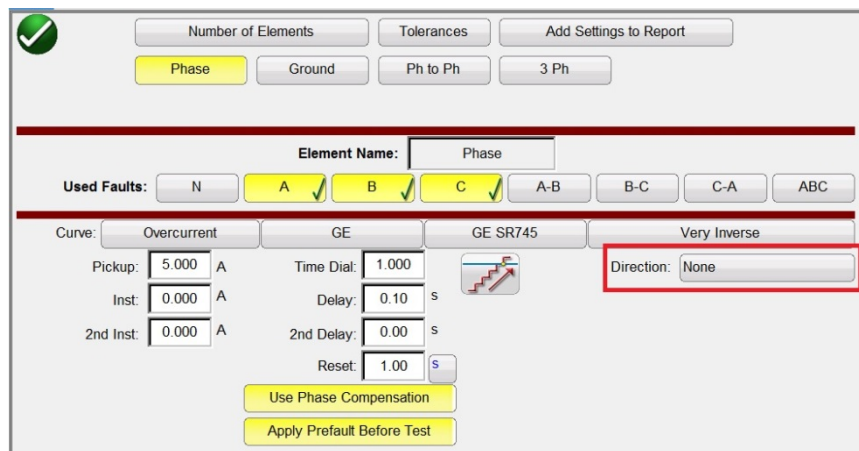

Figure 115 Direction Button location (Red boxed) for the GE SR745 Phase Screen

Three options can be selected: None, Reverse and Forward.



Figure 116 Direction Options List

Leaving it defaulted to **None**, the user will be able to perform a test on a bidirectional relay (50/51).

Selecting **Reverse** or **Forward** button, user will be able to perform a test on a directional relay (67). MTA, Blinder, and Reference Voltage options are available when one of these buttons is pressed. See the following figure.

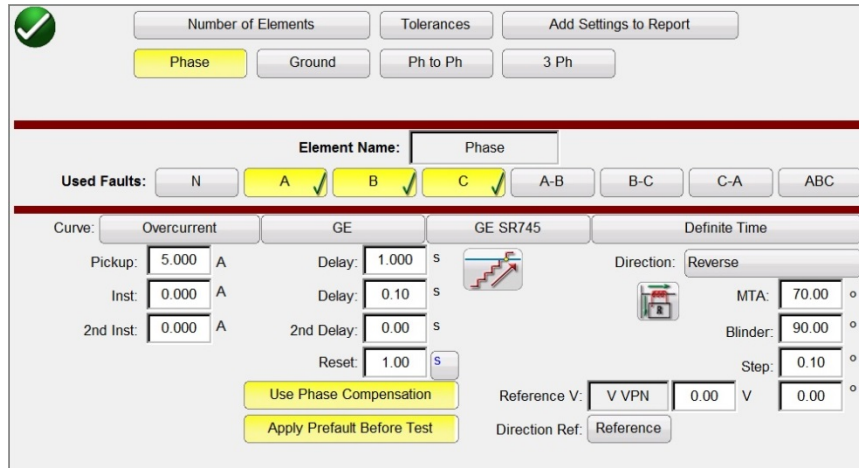



Figure 117 Directional Parameters Screen



**Directional:** For testing directional overcurrent relays which require a voltage to be applied to polarize and close the directional element, click on the Direction button to provide the directional settings. The user needs to enter the desired fault voltage if required and set the CT polarity (current in or out of

polarity) by clicking on the graphic .

This will automatically set the phase angle relationship of either 0 or 180 degrees for the output current relative to the voltage fault.

**Pickup:** The user can select if there are both pick up and dropout tests by clicking on the Ramp icon  changing single ramp to double ramp up and down for pickup and dropout.

**Reset Time:** It is a numerical value of time, normally associated with electromechanical relays. This is the amount of time required for the operating disk to reset. If multiple timing tests are to be conducted on a relay, the test system will wait the Reset Seconds value prior to applying the next timing test. Numerical relays also can have programmable reset times to coordinate with electromechanical relays.

User can define the Reset time interval among tests in seconds  or cycles . The previous selection affect the Delay and 2nd Delay measurement unit.

□ Note, if the Reset Seconds is set too short, and the disk does not completely reset, then timing error will be introduced to the test. This note applies only for electromechanical relays.

**Use Phase Compensation:** Enable this button when performing single phase, or phase-to-phase tests on three phase relays, when you do not want to operate the ground element.

**Apply Prefault Before Test:** Enable this button to apply prefault voltage values for relays with directional elements to get proper polarization prior to applying the fault condition.

**Reference V:** Allows the user to define the reference voltage level and angle for directional elements. User can select phase to earth, phase to phase, or Zero sequence.



Figure 118 Phase Reference Selection Buttons

**Directional Ref:** Defaults to Reference, where A Phase voltage will be reference angle in the phase angles displayed in the directional tests. Clicking or pressing on the Reference button will enable Actual, where angles displayed are based upon the phase tested, i.e., B Phase.

**MTA (Maximum Torque Angle):** The maximum torque angle (MTA) is defined as the angle by which the current applied to the relay must be displaced from the voltage applied to the relay to produce maximum torque.

The voltage reference is used to determinate the polarizing signal for the overcurrent directional element. The signal polarizing will be determined by comparing the phase angle between the current from the phase and VA-B or VA-N and set MTA angle in the relay.

PHASE	OPERATING SIGNAL	POLARIZING SIGNAL V <sub>pol</sub>	
		ABC PHASE SEQUENCE	ACB PHASE SEQUENCE
A	Angle of I <sub>a</sub>	Angle of V <sub>bc</sub> × (Angle of MTA)	Angle of V <sub>cb</sub> × (Angle of MTA)
B	Angle of I <sub>b</sub>	Angle of V <sub>ca</sub> × (Angle of MTA)	Angle of V <sub>ac</sub> × (Angle of MTA)
C	Angle of I <sub>c</sub>	Angle of V <sub>ab</sub> × (Angle of MTA)	Angle of V <sub>ba</sub> × (Angle of MTA)

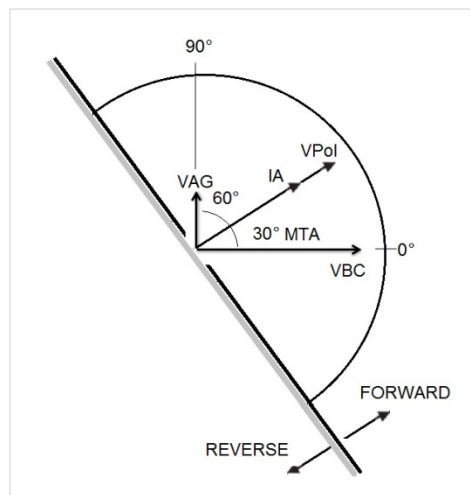

As figure shows for overcurrent directional will operate, when angle current reach the polarizing voltage, this polarizing voltage comes from VA-B reference voltage angle previously configured by user, plus MTA configured in the relay and RTMS.

$$V_{Pol} = V_{BC} \times (1 \angle MTA) = \text{Polarizing Voltage}$$

IA = Operating Current  
 MTA = Element Characteristic Angle at 30°

If user use a reference voltage angle VAG, the current operating will be calculated the same way than VAB reference voltage angle. The relay will operate by comparing the angle between current and polarizing voltage. One more time:  
 VPol = VAN x (1∠ MTA) = Polarizing Voltage

**Blinders:** Is the zone limited by the angles between VPol and the angles previously configured by user. Note there are two angles that the user can enter. They are defaulted to 90 and 0 degrees. Once the Curve type and its parameters (Pickup, Time Dial, Inst, 2<sup>nd</sup> Inst, Delay, 2<sup>nd</sup> Delay) and Direction Type and its parameters (Reset, MTA, Blinders, Reference – Elements, Voltage and Angle)

has been selected and configured, the user needs to press the Green Circle Check Button 

### 3.5.6.1.3 Run Test Screen

The depending on the Elements, by default the first test will start with the Phase Pickup.

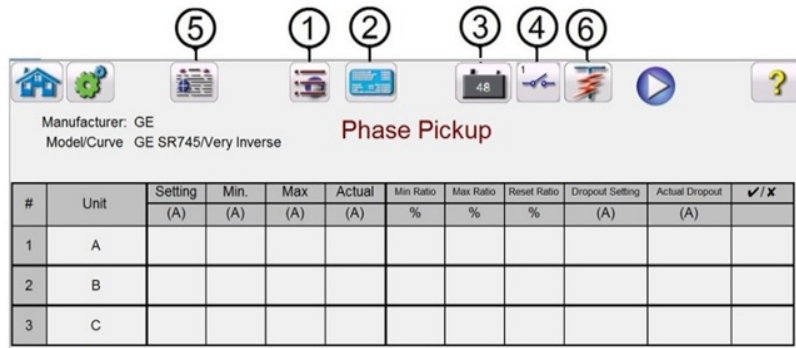



Figure 119 Run Test Screen

#### 3.5.6.1.3.1 Change Test Button

Pressing this button ① the user will be presented with a list of available tests depending on what Elements were originally defined by the user.



Figure 120 Example of Elements Test List

The user can execute them pressing the Run Single Test Arrow Button , which opens the dialog box to choose among the options available. See the following figure.

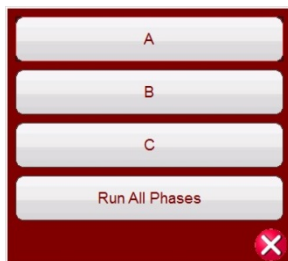

Figure 121 Example Phase Element Test Selection Screen

This dialog box allows the user to perform phase test individually, or to perform Run All Phases Tests in a row.

#### 3.5.6.1.3.2 ② Relay Settings Button

Press this button to access the selection of the Relay's Settings Screen. Here the user can adjust parameters such as Curve/Pick up/Time Dial/Instantaneous/Delay/Direction, etc.

#### 3.5.6.1.5.3 ③ Battery Simulator Button

The Battery Simulator Button – Turns the Battery Simulator ON and OFF by pressing the button, the background color changes red for ON and gray for OFF. The voltage to be applied is displayed in the button and can be changed by pressing the configuration button.

#### 3.5.6.1.5.4 ④ Binary Input Setting button

Press this button to reveal the Binary Input Dialog box.

#### 3.5.6.1.5.5 ⑤ Report Options button

Press or click on this button to view or delete current test results.

#### 3.5.6.1.5.6 ⑥ Run a Predefined Test button

Pressing the Predefined Test button provides access to Predefined Tests, created by either Megger or users.

### 3.5.6.1.6 Performing Tests

The system is ready to select and perform tests. The following are example tests for Phase and Ground Elements. Based upon the values entered by the user in the settings screen, the software will automatically perform Pass ✓ or Fail ✗ evaluation on all tests.

### 3.5.6.1.6.1 Phase Pickup Button



Press this button to go to Phase Pickup Test Screen

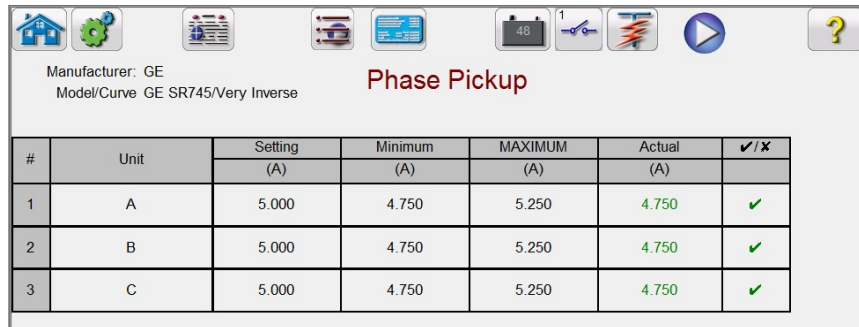
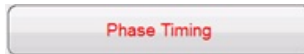

Figure 122 Example Phase Pickup and Dropout Test Screen

This example includes the dropout test, see Figure 81 for example selection and settings.

### 3.5.6.1.6.2 Phase Timing Button



Press this button to go to Phase Timing Test Screen

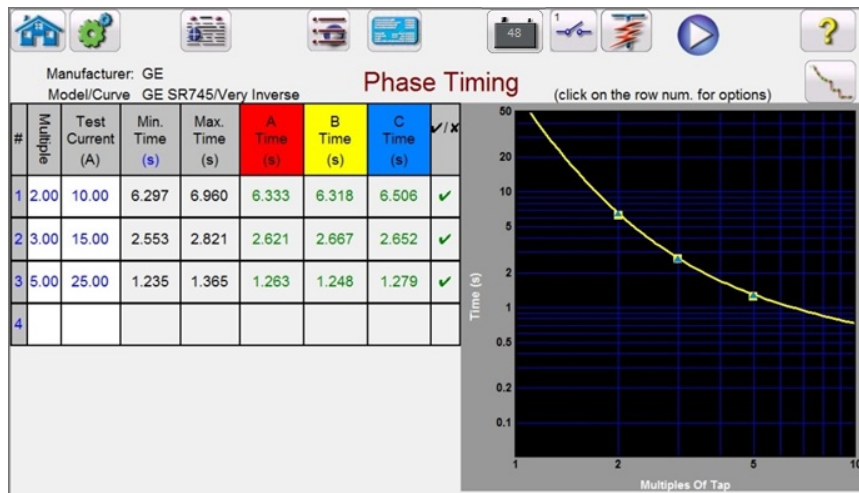
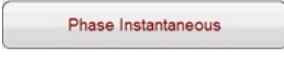

Figure 123 Example Phase Timing Test Screen

This screen allows the user to run phase time overcurrent test previously configured and see the test results. During the test, the user will see the test time vector moving in real time at the desired test multiple. In the left hand side of the test screen the user will see the test current being applied, and the timer is running. When the relay trips the test time is recorded and the Pass/Fail evaluation is automatically displayed. If the Show % Error was selected in the Relay Tolerance Setup screen the % Error would appear directly under the recorded trip time for each test.

For phase timing overcurrent test, the user can execute them pressing the Run Single Test Button, it opens the dialog box to choose among the options available. The user can change value of the test **Multiple** by clicking in the desired cell to change the value of multiple (times pickup). To add more test points the user presses or clicks on the blank **Multiple** windows and enters the desired value. The

software will automatically calculate the min and max allowable time based upon the manufacturer's time curve. If user runs a phase timing overcurrent test and the test reaches the max time on, then a text box will appear "max time on exceeded." The test example above shows only single-phase time elements. You can also have phase to phase and/or three phase timing tests depending on the user inputs.

3.5.6.1.6.3 Phase Instantaneous Button 

Press this button to go to Phase Instantaneous Test Screen

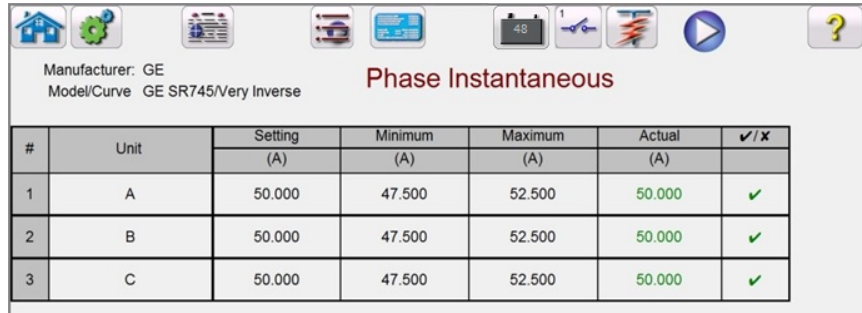

#	Unit	Setting (A)	Minimum (A)	Maximum (A)	Actual (A)	✓/✗
1	A	50,000	47,500	52,500	50,000	✓
2	B	50,000	47,500	52,500	50,000	✓
3	C	50,000	47,500	52,500	50,000	✓

Figure 124 Example Phase Instantaneous Test results.

For phase instantaneous overcurrent tests, the user can execute them pressing the Run Single Test

Button , it opens the dialog box to choose among the options available. When user sets a current test higher than amplifier capability and try to run the test, a warning window will appear explaining why the test will not run. The user can reduce the test requirements or wire channels into a parallel connection. See figure below.

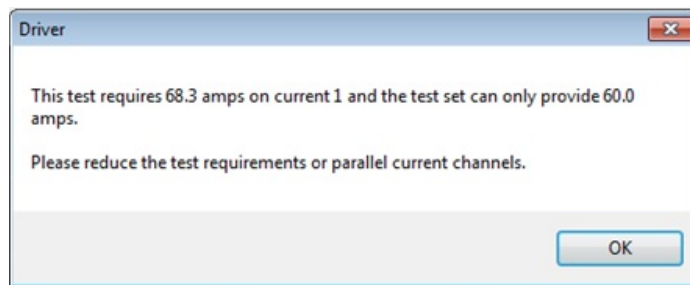



Figure 125 Warning Message

3.5.6.1.6.4 Phase Directional Button 

Press this button to go to Phase Directional Test Screen

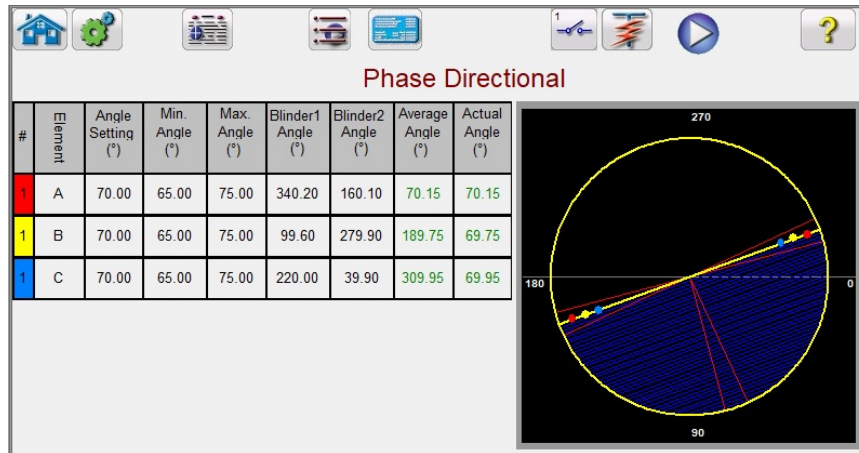

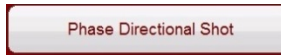

Figure 126 Phase Directional Test Screen

In this screen user can execute the Phase Directional test by pressing the Run Single Test button. In the right hand side of the test screen, the user will see the test phasor moving in real time, and in the left hand side see the actual test values changing. When the test is completed, the Max Angle of Torque (MTA) is calculated and displayed. Pass/Fail is indicated in the View Report by pressing the Reports Options  button.

3.5.6.1.6.4.1

Phase Directional Shot Button



Press this button to go to Phase Directional Shot Test Screen. To create test points, click in the characteristic window above and below the directional characteristic. The following is an example with six test points, three above and three below the directional line.

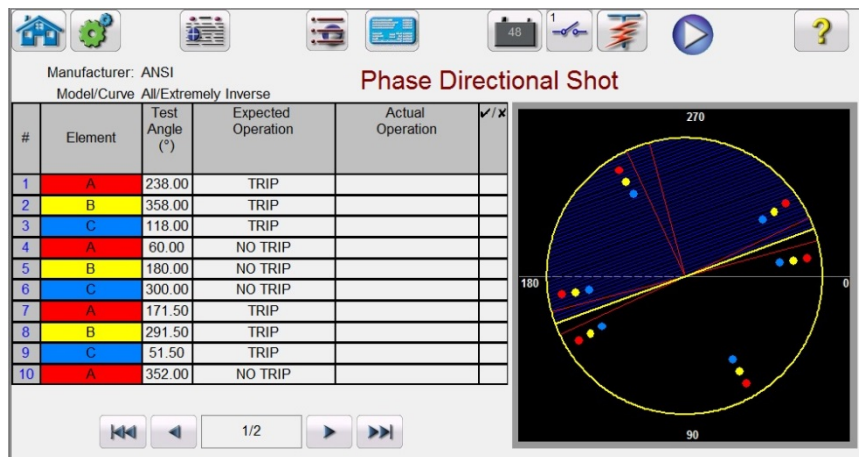



Figure 127 Phase Directional Shot Test Screen

This is a Trip or No Trip test. Up to fifty test points can be selected. Note that additional pages will be added with more test points. Execute the test by pressing the Blue Run Test button. When the test is completed, Pass/Fail is indicated in the right column with a ✓ or ✗. View Test Report by pressing the

Reports Options  button.

3.5.6.1.6.5 Ground Pickup Button 

Press this button to go to Ground Pickup Test Screen



Figure 128 Example Ground Pickup Test

3.5.6.1.6.6 Ground Timing Button 

Press this button to go to Ground Timing Test Screen

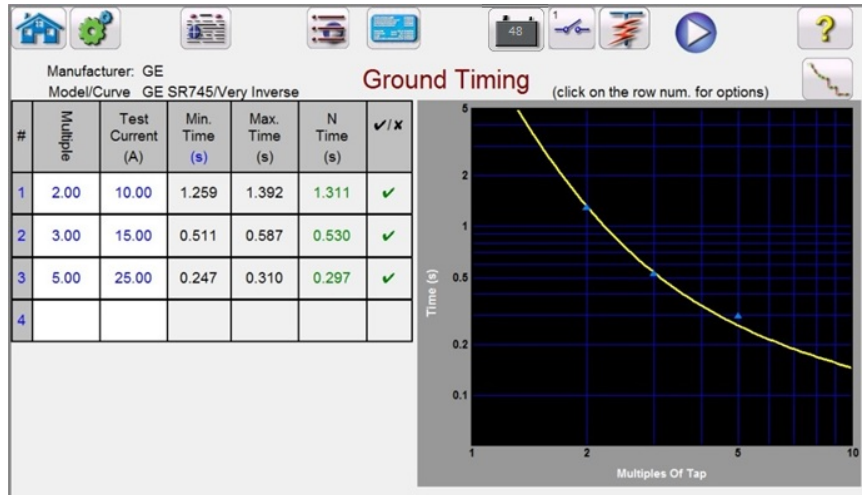



Figure 129 Example Ground Timing Test Screen

This screen allows user to run ground time overcurrent test previously configured and see the test results. During the test, the user will see the test time vector moving in real time at the desired test multiple. In the left hand side of the test screen the user will see the test current being applied, and the timer is running. When the relay trips the test time is recorded and the Pass/Fail evaluation is automatically displayed. If the Show % Error was selected in the Relay Tolerance Setup screen the % Error would appear directly under the recorded trip time for each test.

For ground timing overcurrent test, the user can execute the test by pressing the Run Single Test Button , it opens the dialog box to choose among the options available. The user can change value of the test **Multiple** by clicking in the desired cell to change the value of multiple (times pickup). To add more test points the user presses or clicks on the blank **Multiple** windows and enters the desired value. The software will automatically calculate the min and max allowable time based upon the manufacturer's time curve. If user runs a phase timing overcurrent test and the test reaches the max time on, then a text box will appear: "max time on exceeded." This means than object under test did not operate.



### 3.5.6.1.6.7 Ground Instantaneous Button

Press this button to go to Ground Instantaneous Test Screen

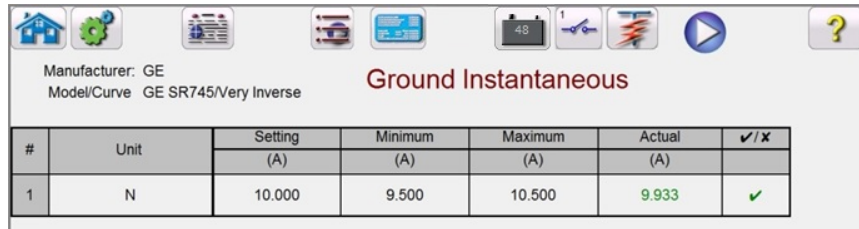



Figure 130 Example Ground Instantaneous Test Screen

For ground instantaneous overcurrent tests, the user can execute them pressing the Run Single Test Button , it opens the dialog box to choose among the options available. If a user sets a current test higher than amplifier capability and try to run the test, a warning window will appear explaining why it will not run the test (this is because the required test current value is higher than the amplifier capability). The user can reduce the single channel test current requirement or wiring into a parallel connection channel. See figure below.

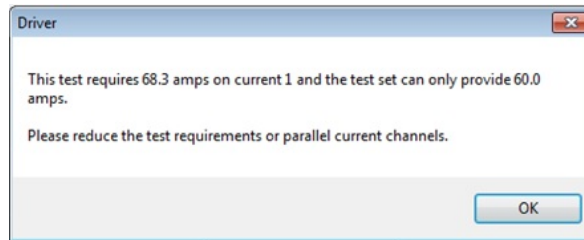
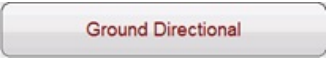

Figure 131 Example Warning Message



### 3.5.6.1.6.8 Ground Directional Button

Press this button to go to Ground Directional Test Screen

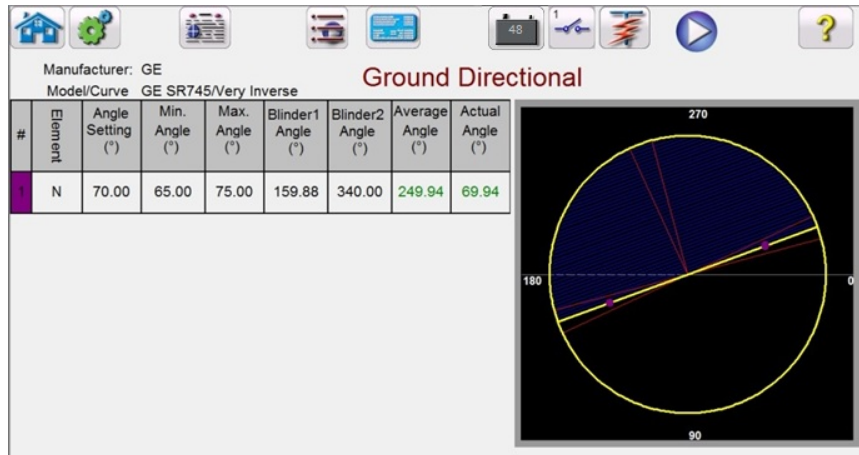



Figure 132 Example Ground Directional Test Screen

In this screen user can execute the Ground Directional test by pressing the Blue Run Test button. In the right hand side of the test screen the user will see the test phasor moving in real time, and in the left hand side see the actual test values changing. When the test is completed, the Max Angle of Torque (MTA) is calculated and displayed. Pass/Fail is indicated in the View Test Report by pressing the Report Options  button.

### 3.5.6.1.6.8.1 Ground Directional Shot Button

Press this button to go to Ground Directional Shot Test Screen. To create test points, click in the characteristic window above and below the directional characteristic. The following is an example with six test points, three above and three below the directional line.

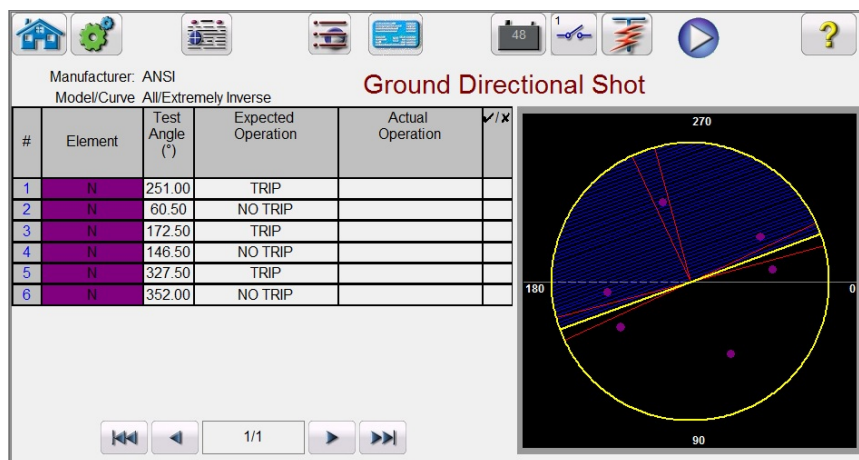

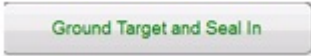

Figure 133 Phase Directional Shot Test Screen

This is a Trip or No Trip test. Up to fifty test points can be selected. Note that additional pages will be added with additional test points. Execute the test by pressing the Blue Run Test button. When the

test is completed, Pass/Fail is indicated in the right column with a ✓ or ✗. View Test Report by pressing the Report Options  button.

3.5.6.1.6.9 Ground DC Target and Seal-In Button 

Press this button to go to Ground Target and Seal-In Test Run Screen

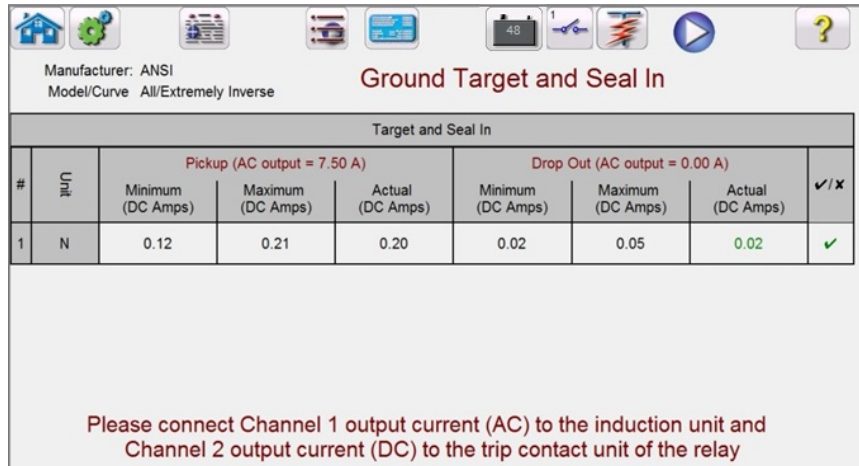



Figure 134 Example Ground Target and Seal In test screen.

The software will show a warning message with the Connection Guidance that need to be verified prior to running the test. Since there are no readily available contacts to monitor, the user will be instructed to press the simulate button during this test when contacts close and open. Pressing the blue Run Test button a message window will appear instructing the user to press the simulate button when the relay trip contacts close. DC current will then be applied to the DC target and seal-in unit. Another message will instruct the user to press the simulate button when the DC target drops/picks up. Another message will appear instructing the user to press the simulate button when the DC targets drops out as the DC current is lowered.

3.5.7 Testing Over Voltage Relays

Pressing the Over Voltage Timing  button will go to the Relay Tolerance Setup Screen,

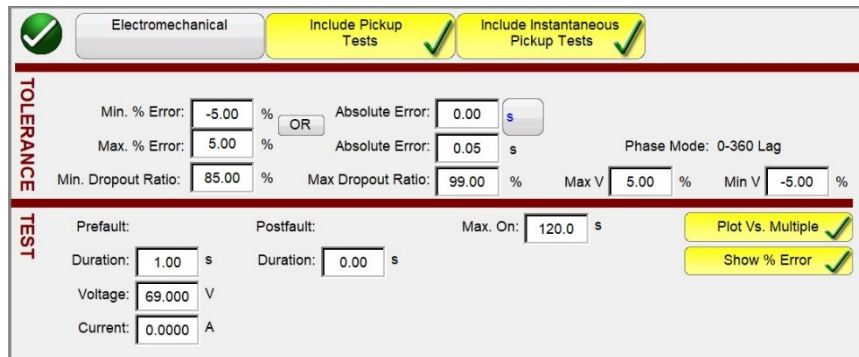

Figure 135 Relay Tolerance Setup Screen

The user will see three buttons on top of screen:

1. Electromechanical
2. Include Pickup Tests
3. Include Instantaneous Pickup Tests

The user can check one, two or all buttons or uncheck them to add or not to add the respective test button to the List of Tests to Run.



Figure 136 Test Selection Buttons

When Electromechanical Button is checked, Include Target and Seal-In Tests Button will appear and is available to be checked or leave it unchecked. If checked it provides the user with the appropriate outputs necessary (typically 0.2, or 2 A) to do a pickup and dropout test on an electromechanical DC Target and Seal In relay.

- Application Note: It is difficult to monitor the seal in contacts, therefore, it is up to the user to observe the contacts and press the SIM button when the seal in contacts close or opens.

### Tolerance Settings

The user needs to enter the Manufacturer's Tolerance Specifications, which are found in relay's user guide. The **Absolute Error** can be written in Seconds (s) or Cycles (Cy) by pressing on the  button.

The user needs to define the following:

**Prefault Duration:** Time duration for application of a Prefault voltage (for simulating normal condition).

**Prefault Voltage and Current Levels:** Enter the appropriate voltage and/or current levels.

**Post fault Duration:** Amount of time the fault voltage will be applied after sensing trip.

**Max On:** Time the test will be performed (the maximum time the fault voltage will be applied).

**Plot vs. Voltage:** The default timing test will provide a graphic that will plot the **Time vs. Voltage**. Pressing the button will result in the graphic changing to **Time vs. Multiples of Tap**.

**Show % Error:** When checked the timing results will display with % error.

Once tolerance, test data are completed, pressing the green circle check button will take the user to the Phase setting window as shown below.

### Number of Elements button

The user needs to define the elements of the protective relay to be tested. The screen has up to 24 Elements windows available. Pressing the Elements button will display the following screen (shown here with 24 Elements entered in the window). If the relay has phase to phase and three phase over voltage elements, they can be easily added to the blank Element windows.

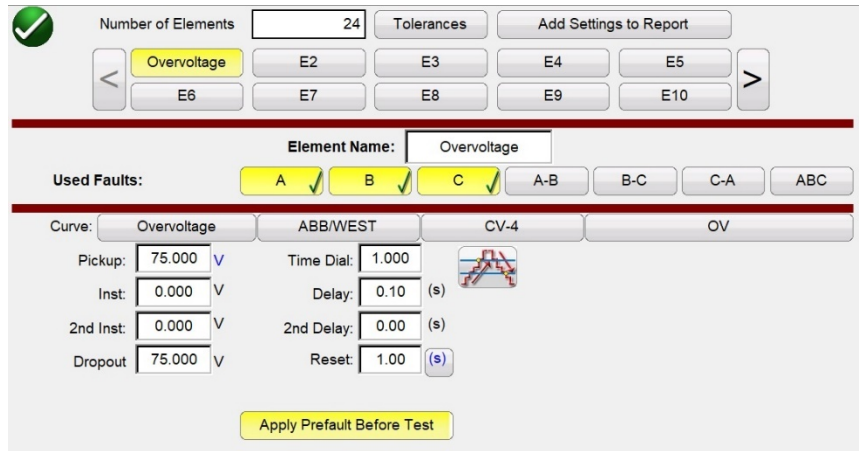



Figure 137 Overvoltage Phase Element Setting Screen

Note the Element Name can be changed by clicking in the **Element Name** window, and a virtual keyboard will appear.

Selecting the double ramp  will open the Dropout value window as shown in the above example. Therefore, when performing the Phase Pickup test, both pickup and dropout tests will be performed.

**Tolerances** button takes you back to the tolerance-setting screen.

#### 3.5.7.1 Manufacturer Selection Button

Pressing the default **ABB/WEST Curve** button will provide access to the Manufacturers voltage relay time curves, see the figure below.



Figure 138 Voltage Relay Manufacturer Selection Screen

#### 3.5.7.2 Manufacturer's Model Button

Selecting a manufacturer will provide access to all models available for that manufacturer.



Figure 139 Example ABB/WEST Relay Model Selection Screen

### 3.5.7.3 Run Test Screen

The depending on the Elements, by default the first test will start with the Phase Pickup.

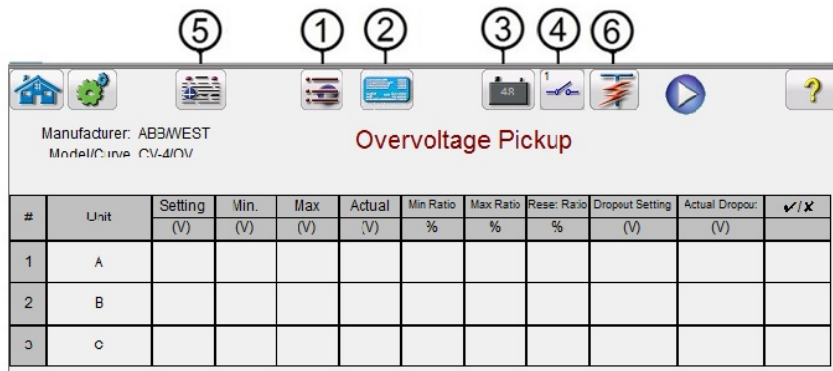



Figure 140 Overvoltage Phase Pickup Test Screen

#### 3.5.7.3.1 Change Test Button

Pressing this button ① the user will be presented with a list of available tests depending on what Elements were originally defined by the user.



Figure 141 Example of Elements Test List

The user can execute them pressing the Run Single Test Button , which opens the dialog box to choose among the options available. See the following figure.

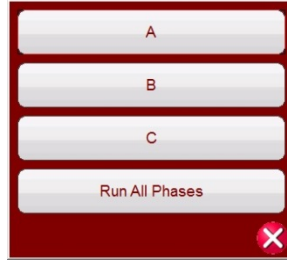



Figure 142 Example Phase Element Test Selection Screen

This dialog box allows the user to perform phase test individually, or to perform Run All Phases Tests in a row.

3.5.7.3.2 ② Relay Settings Button 

Press this button to access selection of the Relay's Settings Screen. Here the user can adjust parameters such as Curve/Pick up/Time Dial/Instantaneous/Delay, etc.

3.5.7.3.3 ③ Battery Simulator Button 

The Battery Simulator Button – Turns the Battery Simulator ON and OFF by pressing the button, the background color changes red for ON and gray for OFF. The voltage to be applied is displayed in the button and can be changed by pressing the configuration button.

3.5.7.3.4 ④ Binary Input Setting button 

Press this button to reveal the Binary Input Dialog box.

3.5.7.3.5 ⑤ Report Options button 

Press or click on this button to view or delete current test results.

3.5.7.3.6 ⑥ Run Predefined Test button 

Pressing the Run Predefined Test button provides access to Predefined test plans, created by either Megger or users, in Pdb.Tst file structure.

### 3.5.7.4 Performing Tests

The system is ready to select and perform tests. The following are example tests for Phase Elements. Based upon the values entered by the user in the settings screen, the software will automatically perform Pass ✓ or Fail ✗ evaluation on all tests.

3.5.7.4.1 Phase Pickup Button 

Press this button to go to Phase Pickup Test Screen

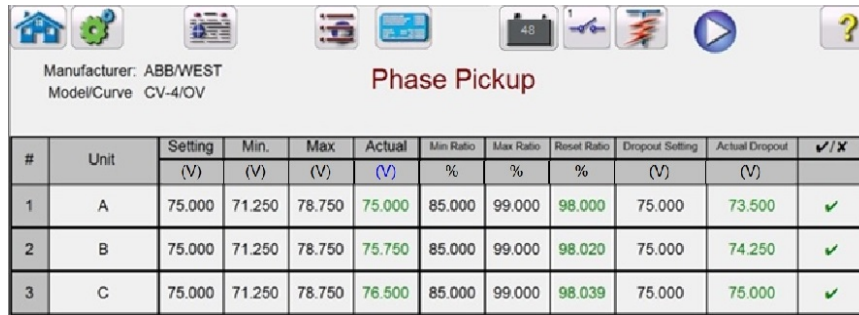

Figure 143 Example Phase Pickup and Dropout Test Screen

This example includes the dropout test.

### 3.5.7.4.2 Phase Timing Button



Press this button to go to Phase Timing Test Screen

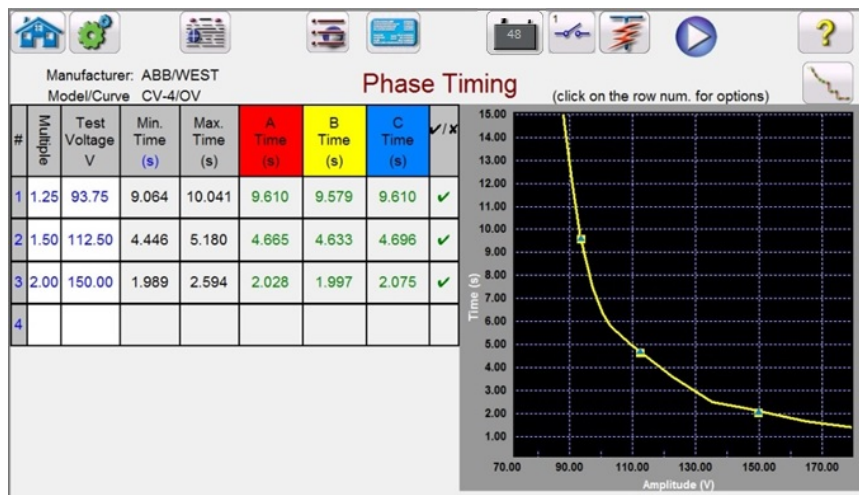

Figure 144 Example Phase Timing Test Screen

This screen allows the user to run phase time over voltage test previously configured and see the test results. During the test, the user will see the test time vector moving in real time at the desired test multiple. In the left hand side of the test screen the user will see the test voltage being applied and the timer is running. When the relay trips the test time is recorded and the Pass ✓/Fail ✗ evaluation is automatically displayed. If the **Show % Error** was selected in the Relay Tolerance Setup screen the % Error would appear directly under the recorded trip time for each test.

For phase timing over voltage test, the user can execute them pressing the Run Single Test Button



, it opens the dialog box to choose among the options available. The user can change value of the test **Multiple** by clicking in the desired cell to change the value of multiple (times pickup). To add more test points the user presses or clicks on the blank **Multiple** windows and enters the desired value. The software will automatically calculate the min and max allowable time based upon the manufacturer’s time curve. If user runs a phase timing over voltage test and the test reaches the max time on, then a text box will appear “max time on exceeded.” The test example above shows only single-phase time

elements. You can also have phase to phase and/or three phase timing tests depending on the user inputs.

### 3.5.7.4.3 Phase Instantaneous Button



Press this button to go to Phase Instantaneous Test Screen

Manufacturer: IEC  
Model/Curve All/Definite Time (over)

#	Unit	Setting (V)	Minimum (V)	Maximum (V)	Actual (V)	✓/X
1	A	150.000	142.500	157.500	149.000	✓
2	B	150.000	142.500	157.500	150.000	✓
3	C	150.000	142.500	157.500	150.000	✓

Figure 145 Example Phase Instantaneous Test results.

For phase instantaneous over voltage tests, the user can execute them pressing the Run Single Test Button , it opens the dialog box to choose among the options available.

### 3.5.8 Testing Under Voltage Relays

Pressing the Under Voltage Timing  button will go to the Relay Elements and Tolerance Setup Screen,

Electromechanical  Include Pickup Tests  Include Instantaneous Pickup Tests

**TOLERANCE**

Min. % Error:  % OR Absolute Error:  s  
 Max. % Error:  % OR Absolute Error:  s  
 Phase Mode: 0-360 Lag

Min. Dropout Ratio:  % Max Dropout Ratio:  % Max V  % Min V  %

**TEST**

Prefault:  s Postfault:  s Max. On:  s Plot Vs. Voltage   
 Duration:  s Duration:  s

Voltage:  V  
 Current:  A

Figure 146 Under Voltage Relay Tolerance Setup Screen

The user will see three buttons on top of screen:

1. Electromechanical
2. Include Pickup Tests
3. Include Instantaneous Pickup Tests

The user can check one, two or all buttons or uncheck them to add or not to add the respective test button to the List of Tests to Run.

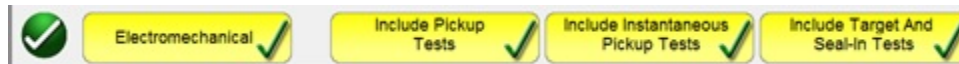



Figure 147 Test Selection Buttons

When Electromechanical Button is checked, Include Target and Seal-In Tests Button will appear and is available to be checked or leave it unchecked. If checked it provides the user with the appropriate outputs necessary (typically 0.2, or 2 A) to do a pickup and dropout test on an electromechanical DC Target and Seal In relay.

 Application Note: It is difficult to monitor the seal in contacts, therefore, it is up to the user to observe the contacts and press the SIM button when the seal in contacts close or opens.

### Tolerance Settings

The user needs to enter the Manufacturer's Tolerance Specifications, which are found in relay's user guide. The **Absolute Error** can be written in Seconds (s) or Cycles (Cy) by pressing on the  button.

The user needs to define the following:

**Prefault Duration:** Time duration for application of a Prefault voltage (for simulating normal condition).

**Post fault Duration:** Amount of time the fault voltage will be applied after sensing trip.

**Max On:** Time the test will be performed (the maximum time the fault voltage will be applied).

**Prefault Voltage and Current Levels:** Enter the appropriate voltage and current levels.

**Plot vs. Voltage:** The timing test will provide a graphic that will plot the **Time vs. Voltage**. Pressing the button will result in the graphic changing to **Time vs. Multiples of Tap**.

**Show % Error:** When checked the timing results will display with % error.

Once tolerance, test data are completed, pressing the green circle check button will take the user to the Phase setting window as shown below.

### Number of Elements button

The user needs to define the elements of the protective relay to be tested. The screen has up to 24 Elements windows available. Pressing the Elements button will display the following screen (shown here with 24 Elements entered in the window). If the relay has phase to phase and three phase over voltage elements, they can be easily added to the blank Element windows.

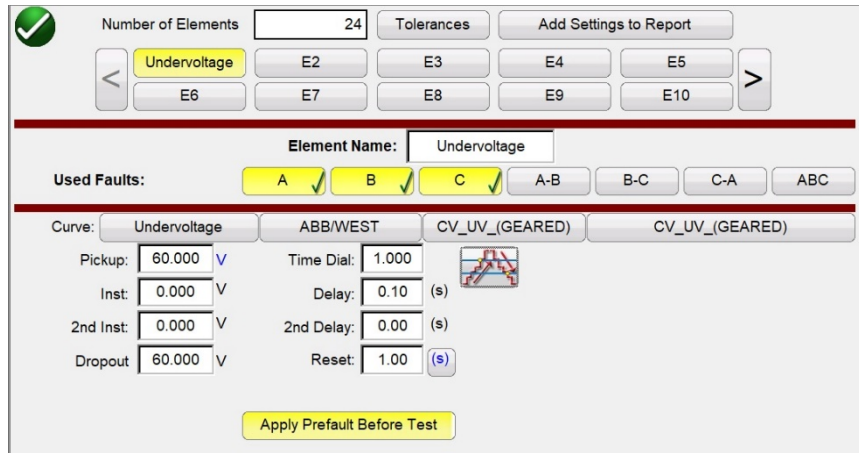



Figure 148 Under Voltage Phase Element Setting Screen

Any Elements added will appear here, next to the Undervoltage button, to enter settings. Note the Element Name can be changed by clicking in the **Element Name** window, and a virtual keyboard will appear.

Selecting the double ramp  will open the Dropout value window. Therefore, when performing the Phase Pickup test, both pickup and dropout tests will be performed.

### 3.5.8.1 Manufacturer Selection Button

Pressing the default ABB/WEST curve button will provide access to the under-voltage time curves. For other available manufacturers, see the following figure.

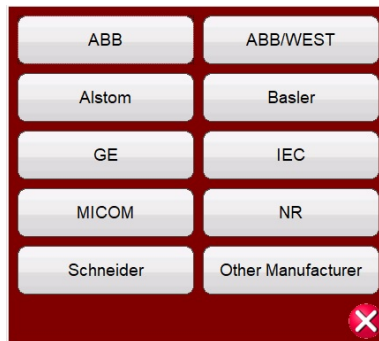

Figure 149 Voltage Relay Manufacturer Selection Screen

### 3.5.8.2 Manufacturer's Model Button

Selecting a manufacturer will provide access to all models available for that manufacturer.



Figure 150 Example ABB/WEST Relay Model Selection Screen

### 3.5.8.3 Run Test Screen

The depending on the Elements, by default the first test will start with the Phase Pickup.

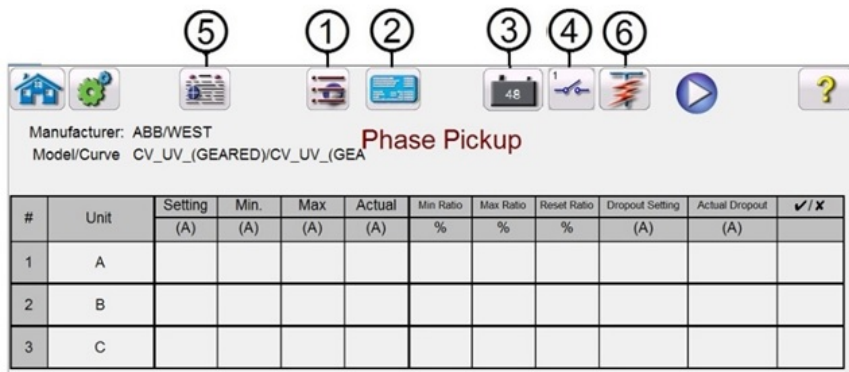

Figure 151 Run Test Screen

#### 3.5.8.3.1 Change Test Button

Pressing this button ① the user will be presented with a list of available tests depending on what Elements were originally defined by the user.



Figure 152 Example of Elements Test List

The user can execute them pressing the Run Single Test Button , which opens the dialog box to choose among the options available. See the following figure.



Figure 153 Example Phase Element Test Selection Screen

This dialog box allows the user to perform phase test individually, or to perform Run All Phases Tests in a row.

#### 3.5.8.3.2 ② Relay Settings Button

Press this button to access selection of the Relay's Settings Screen. Here the user can adjust parameters such as Curve/Pickup/Time Dial/Instantaneous/Delay, etc.

#### 3.5.8.3.3 Battery Simulator Button

The Battery Simulator Button ③ – Turns the Battery Simulator ON and OFF by pressing the button, the background color changes red for ON and gray for OFF. The voltage to be applied is displayed in the button and can be changed by pressing the configuration button.

#### 3.5.8.3.4 Binary Input Setting button

Press this button ④ to reveal the Binary Input Dialog box.

#### 3.5.8.3.5 View Test Results button

Press or click on this ⑤ button to view or delete current test results.

#### 3.5.8.3.6 Run Predefined Test button ⑥

Pressing the Run Predefined Test button provides access to Predefined test plans, created by either Megger or users, in Pdb Tst file structure.

### 3.5.8.4 Performing Tests

The system is ready to select and perform tests. The following are example tests for Phase Elements. Based upon the values entered by the user in the settings screen, the software will automatically perform Pass ✓ or Fail ✗ evaluation on all tests.

#### 3.5.8.4.1 Phase Pickup Button

Press this button to go to Phase Pickup Test Screen

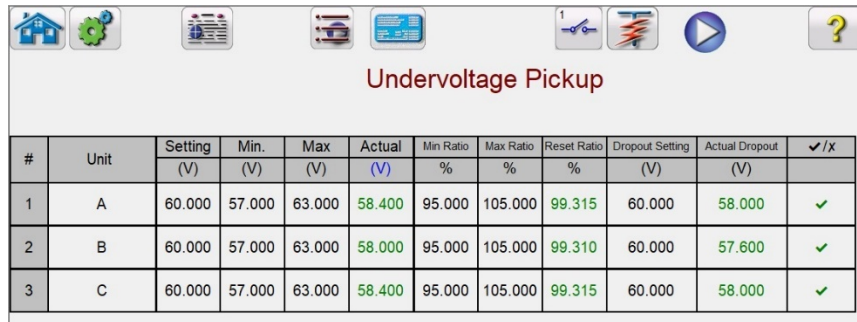

Figure 154 Example UV Phase Pickup Test Screen

### 3.5.8.4.2 Phase Timing Button



Press this button to go to Phase Timing Test Screen

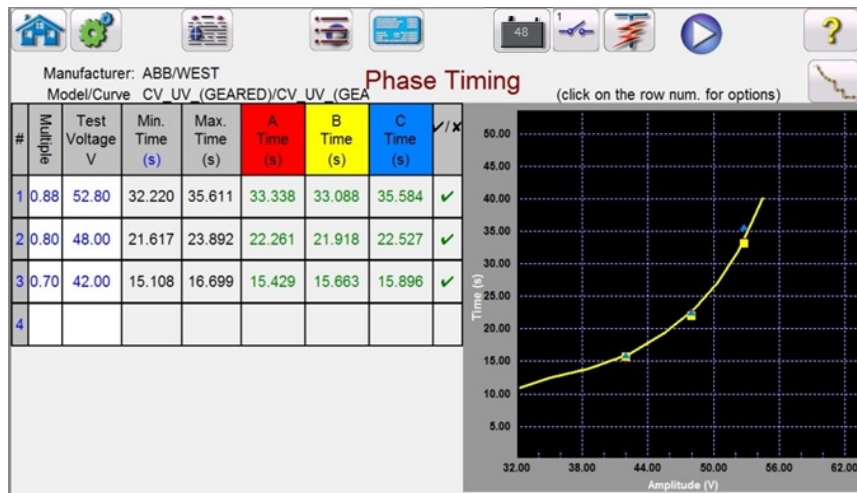

Figure 155 Example UV Phase Timing Test Screen

This screen allows the user to run phase time under voltage test previously configured and see the test results. During the test, the user will see the test time vector moving in real time at the desired test multiple. In the left-hand side of the test screen the user will see the test voltage being applied, and the timer is running. When the relay trips the test time is recorded and the Pass/Fail evaluation is automatically displayed. If the **Show % Error** was selected in the Relay Tolerance Setup screen the % Error would appear directly under the recorded trip time for each test.

For phase timing under voltage test, the user can execute them pressing the Run Single Test Button



, it opens the dialog box to choose among the options available. The user can change value of the test **Multiple** by clicking in the desired cell to change the value of multiple (times pickup). To add more test points the user presses or clicks on the blank **Multiple** windows and enters the desired value. The software will automatically calculate the min and max allowable time based upon the manufacturer's time curve. If user runs a phase timing under voltage test and the test reaches the max time on, then a text box will appear "max time on exceeded." The test example above shows

only single-phase time elements. You can also have phase to phase and/or three phase timing tests depending on the user inputs.

### 3.5.9 State Sequencer Test 1 2 3..9

#### 3.5.9.1 Reclosing Relay Testing

These tests should be conducted in accordance with the manufacturers relay specifications.

Press the Select New Test button  to get access to the State Sequencer Test. Pressing the

1 2 3..9 button on the test menu takes the user to the Sequencer Test Screen defined in the following screen.

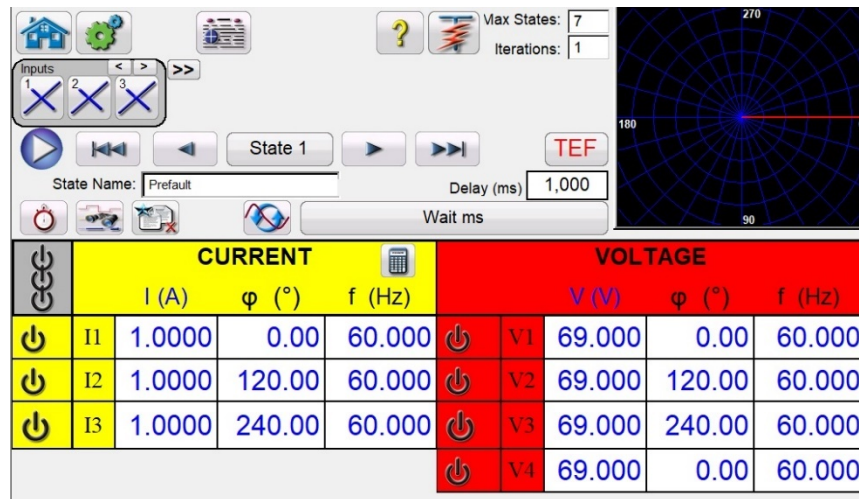



Figure 156 Sequencer Test Screen

**Max States:** There are up to one hundred programmable states available in the Max States setting window. By default, there are seven states already predefined and labeled as *Prefault*, *Trip1*, *Reclose 1*, etc. up to *End of Test* in State 7. Press the Next Step  sequence button to move forward one-state in the sequence. It is initially set up for a three-shot trip-reclose to lockout scenario. Another test application is a developing fault scenario or use to perform dynamic end-to-end tests. The user is free to change the labels or use the default labels. With each state, the user may input values of voltage, current, phase angle, frequency and set the binary input sensing for each state. Both single pole and three pole trips can be simulated. There are default values and binary settings for a single-phase trip and reclose scenario already programmed in (see Binary Input 1 with each state change). The user can either use the defaults or change them to suit the test application, as well as extend or shorten the number of states.

**Iterations:** There are up to 99,999 iterations of the programmed sequence available. The default is set to 1.

Press the **Configure Timer**  button to view the **Timer Setup Configuration** screen and Labels. The user can view and set where each timer starts and stops in association with each trip and reclose operation (see the following figure).

Clear All		TIMER SETUP					
#	Timer Name	Min (sec.)	Max (sec.)	Value (sec.)	Start Condition	Stop Condition	
1	Trip Time 1	0.000	0.000	0.000	State 2	Post 1	
2	Reclose Time 1	0.000	0.000	0.000	State 3	Post 2	
3	Trip Time 2	0.000	0.000	0.000	State 4	Post 1	
4	Reclose Time 2	0.000	0.000	0.000	State 5	Post 2	
5	Trip Time 3	0.000	0.000	0.000	State 6	Post 1	
6	Total Time to Lockout	0.000	0.000	0.000	State 2	State 6	
7							
8							
9							
10							

Figure 157 Sequence Timers Settings and Labels Screen Example

Note that the Total Time to Lockout is also included in the setting and indicates where the total timer starts and stops. This allows for 1, 2, 3, 4 or more shots to lockout including reclose times. To change the Start and Stop conditions, press, or click the appropriate windows. Start or Stop can be set using either the change of State, or Post, or None, see the following start example.



Figure 158 Timer Conditional State Post Selector

Pressing State, the user will be presented with the number of States that were previously set by the user. The user can start or stop the timer when the sequencer steps to that State. Pressing Post, the timer will start or stop based upon the change of the defined binary input Post #, see section 3.1.12 for use of the Binary Input Dialog box. If desired, enter the appropriate minimum and maximum trip and reclose times in the spaces provided. At the end of the test, the test results will include the min, max, and Pass/Fail determination for each state.

Return to the Sequence test screen, to set the conditions for each change of state. Press the **Wait ms** button directly under the Delay time window. The user will be presented with several selections to choose from. These are the conditions that the unit will take to determine when to change to the next state, or end the sequence, see the following menu selection.



Figure 159 State Sequence Conditional Setting Screen

**Wait ms** – The unit will wait for the ms entered in the window before changing to the next state in the sequence.

**Wait Cycles** – The unit will wait for the Cycles entered in the window before changing to the next state in the sequence.

**Wait Any (Continue)** – Wait for any of the configured binary inputs to be true and then continue with the sequence. Note that an input can be configured for the Wait Any (OR) and Wait All (AND) conditions by clicking on the binary inputs.

**Wait Any (Abort)** – The unit will wait for any of the configured binary inputs to be true, and then continue with the sequence. If no binary inputs become true before the **Timeout** setting value, the test will be aborted.

**Wait All (Continue)** – Wait for all selected binary input conditions to become true, or the Timeout is exceeded before continuing to the next state.

**Wait All (Abort)** – Wait for all selected binary input conditions to become true, or the Timeout is exceeded before continuing to the next state. If all selected binary inputs have not become true by the **Timeout** setting value, abort the test.

**Wait IRIG** – Connect the IRIG-B time source to Binary Input #1. Binary Input #1 has the capability to decode the IRIG-B time, *when the IRIG button is enabled in the Configuration screen*. Select the Wait IRIG and enter the desired time to start the test. The unit will wait for the IRIG Time entered in the IRIG window before changing to the next state in the sequence (used for end-to-end tests).

**POP** – Some GPS units have a programmable output voltage trigger port to start a timing sequence, such as an end-to-end test. Connect the POP (Programmable Output Pulse) port from a GPS receiver to Binary Input #1. Selecting this option will change Binary Input #1 to voltage input trigger with the threshold set at 4 Volts. Note: The voltage threshold can be set to as low as two volts if required.

**End** – If the relay under test makes it to this state, end the test.

Press the Copy Paste button  to copy any State configuration and paste it into another State. This tool is especially useful when repeating states such as multiple trip/reclose tests.

Pressing the Reset Phase button  restores the phase relationship of all selected generators for the selected State.

 Application Note: Use of the Reset Phase button is recommended when performing an End-to-End test, so that both test systems are in the same known phase angle relationship at the start of the test. This is also useful when the frequency of a generator is changed from one state to another, its phase relationship to the other generators will be unpredictable. By restoring the phase relationship for the state change in frequency, the frequency change takes place at a known phase angle relationship to the other phases.

To set the Binary Outputs to simulate the 52a and/or 52b contacts press the Binary more  button next to the Binary Inputs to expand the selection window. In the predefault state you may choose to have Binary Output 1 contact in the closed condition to simulate breaker closed. Click on Binary Output 1 and the binary output setting window will appear. The default setting is Open. Click on the Close Contact Button to simulate breaker closed. Note the Name in the window is defaulted to one. The user is free to rename it to any value such as 52a. To rename the binary inputs or outputs, press or click in the Name window, and the virtual keyboard will appear. Up to six characters will appear in the binary window in the test screen. Press or click on the green check button to return to the test screen.

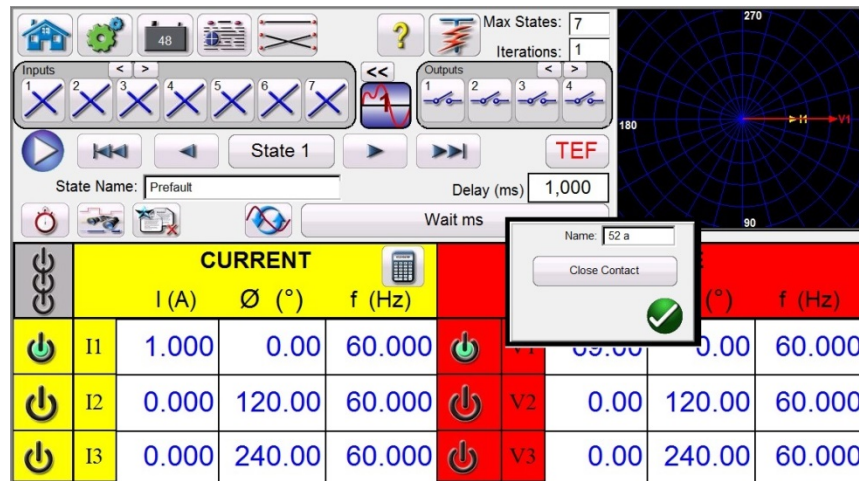



Figure 160 Binary Output Setting Screen

Once all the Binary Inputs, Outputs, Prefault, Fault and Reclose settings are completed, the user can then press the Preview  button to get a visual representation of the voltage and current outputs, as well as a visual of the binary inputs and outputs for each stage of the simulation. The following figures illustrate an example trip and reclose sequence.

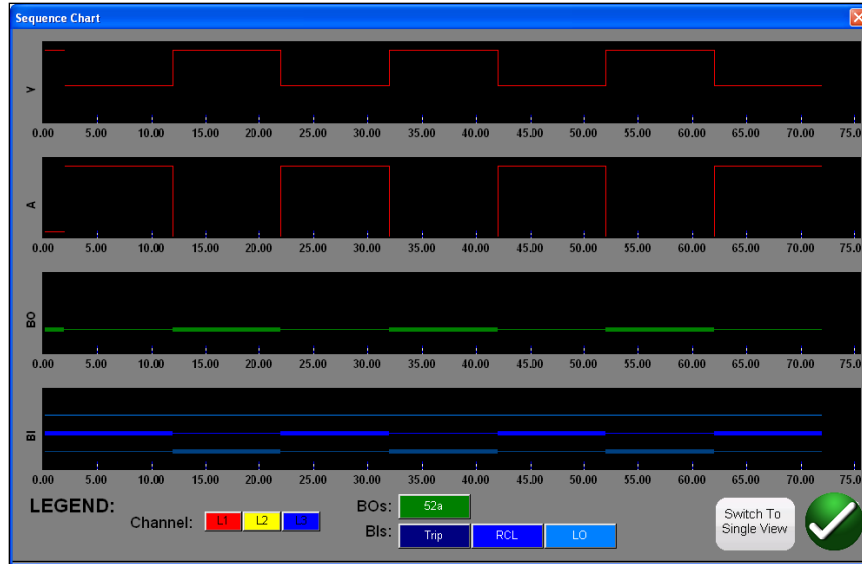



Figure 161 State Sequence “Split View” Preview Screen

There are two views available to the user. One view is called the “Single View” where all the voltages, currents, binary inputs, and outputs are overlaid. In the above figure a single phase 4 trip and reclose is shown in the “Split View”, where the voltages, currents, binary inputs, and outputs are split up like a fault recording. The red color is the magnitude of Channel 1(faulted phase) voltage and current outputs. The fat/thin lines represent the binary inputs and outputs per the colors defined in the legend. A “fat” line indicates contacts are closed, and a thin line indicates that the contacts are open. When the fault current is applied, you can see when the trip contacts closed and when the binary output contact opened. When the “breaker” opens you can see the current going to zero. When the breaker closes you see the current being reapplied and then repeat the trip and reclose cycle until lockout. The user can toggle back and forth between the two views by pressing the Switch to Single View/Split View button in the lower right corner of the screen. To exit this screen, press the green check button to return to the State Sequence screen.

To execute the test, press the Blue Run Test button. Save and review test results as previously discussed.

Megger.		RELAY TEST REPORT			8/17/2021					
www.megger.com		PAGE 1			As Found/As Left					
Nameplate Data										
Substation	South 40	Test Status	Pass							
Protection		Job Number								
Manufacturer	Acme	Current Input	Current Transformer							
Model	A1000	Voltage Input	Potential Transformer							
Asset ID	R123098	CT Ratio	1000 A : 1 A	Earthing L->N						
Serial Number	2525058	PT Ratio	1000 V : 1 V							
Relay Firmware		Rotation	Counter Clockwise Rotation 0-360 Lag							
Sequence Test										
#	State	Description	Current			Voltage			Wait Inputs	
			Channel	I (A)	Ø (°)	f (Hz.)	Channel	V (V)		Ø (°)
1	Prefault Wait 10000 ms		I1	0.00	0.0	60.000				
			I2	0.00	120.0	60.000				
			I3	0.00	240.0	60.000				
2	Breaker Close Wait 50 ms		I1	0.00	0.0	60.000				
			I2	0.00	120.0	60.000				
			I3	0.00	240.0	60.000				
3	Prefault 2 Wait 10000 ms		I1	0.10	0.0	60.000				
			I2	0.10	120.0	60.000				
			I3	0.10	240.0	60.000				
4	Breaker Close Wait Any (Continue) Timeout: 50 ms		I1	0.00	0.0	60.000				XXXXXXXXXX
			I2	0.00	120.0	60.000				
			I3	0.00	240.0	60.000				
5	Trip 1 Wait Any (Continue) Timeout: 10000 ms		I1	1.50	0.0	60.000				XXXXXXXXXX
			I2	1.50	120.0	60.000				
			I3	1.50	240.0	60.000				
6	Reclose 1 Wait Any (Continue) Timeout: 6000 ms		I1	0.00	0.0	60.000				XXXXXXXXXX
			I2	0.00	120.0	60.000				
			I3	0.00	240.0	60.000				
7	Breaker Close Wait Any (Continue) Timeout: 50 ms		I1	0.00	0.0	60.000				XXXXXXXXXX
			I2	0.00	120.0	60.000				
			I3	0.00	240.0	60.000				
8	Trip 2 Wait Any (Continue) Timeout: 10000 ms		I1	1.50	0.0	60.000				XXXXXXXXXX
			I2	1.50	120.0	60.000				
			I3	1.50	240.0	60.000				
9	Reclose 2 Wait Any (Continue) Timeout: 15000 ms		I1	0.00	0.0	60.000				XXXXXXXXXX
			I2	0.00	120.0	60.000				
			I3	0.00	240.0	60.000				
10	Breaker Close Wait Any (Continue) Timeout: 50 ms		I1	0.00	0.0	60.000				XXXXXXXXXX
			I2	0.00	120.0	60.000				
			I3	0.00	240.0	60.000				
11	Trip 3 Wait Any (Continue) Timeout: 10000 ms		I1	1.50	0.0	60.000				XXXXXXXXXX
			I2	1.50	120.0	60.000				
			I3	1.50	240.0	60.000				
12	End Of Test END		I1	0.00	0.0	60.000				
			I2	0.00	120.0	60.000				
			I3	0.00	240.0	60.000				
Timer Name		Time (s)	Min. Value (sec.)	Max. Value (sec.)	✓/X					
Trip Time 1		12.210	12.200	12.219	✓					
Reclose Time 1		2.211	2.210	2.220	✓					
Reclose Time 2		7.225	7.220	7.230	✓					
Binary Input/Output Activity										
Time (s)	State #	Transition	Post	CONDITION						
10.000	2	State Change	na	na						
10.000	2	Output Change	1	Closed						
10.050	3	State Change	na	na						
20.050	4	State Change	na	na						
20.100	5	State Change	na	na						
30.100	6	State Change	na	na						
30.100	6	Output Change	1	Open						
32.310	6	Input Change	1	Closed						
32.311	6	Input Change	2	Closed						
32.311	7	State Change	na	na						
32.311	7	Output Change	1	Closed						
32.361	8	State Change	na	na						
32.467	8	Input Change	2	Open						
32.469	8	Input Change	1	Open						
42.361	9	State Change	na	na						
42.361	9	Output Change	1	Open						

Page 1 | Page 2

Form Schema 0, REVISED 10/25/2022

Figure 162 Example Sequencer 3 Shot Trip and Reclose

### 3.5.9.2 Transient Earth-Fault (TEF) Simulator

The Transient Earth Fault simulator is designed for testing the directional operating characteristics of transient and intermittent transient earth fault relays by simulating residual current  $I_0$  and residual voltage  $V_0$  transient signals. The intermittent test feature simulates intermittent transient faults found in compensated cable networks. These types of faults are typically caused by insulation breakdown. They can be repetitive, and noticeably short in duration.

### Transient Earth-Fault

Relay Settings	Operation: <input type="button" value="On"/>	Operate Delay Time: <input type="text" value="500"/> ms
	Operation Mode: <input type="button" value="Transient EF"/>	Voltage Start Value: <input type="text" value="0.2"/> x Vn
	V0 Signal Sel: <input type="button" value="Measured V0"/>	Reset Delay Time: <input type="text" value="500"/> ms
	Directional Mode: <input type="button" value="Forward"/>	Peak Counter Limit: <input type="text" value="2"/>
	<input type="button" value="Display Zones"/>	Min Operate Current: <input type="text" value="0.01"/> x In

---

Test Settings	No. of Transient States: <input type="text" value="2"/>	Inom (sy): <input type="text" value="1"/> A
	Transient Fault Time: <input type="text" value="10"/> ms	Vnom (sy): <input type="text" value="57.74"/> V (L-N)
	Peak Fault Current: <input type="text" value="5"/> x In	
	Peak Fault Voltage: <input type="text" value="5"/> xVn	

Figure 163 Transient Earth-Fault Settings Screen

#### 3.5.9.2 Transient Earth-Fault Relay Settings

The following are typical settings found in Transient Earth Fault relays, and how they are interrelated to the TEF simulation.

**Operation:** On or Off

**Operation Mode:** There are two mode settings, **Transient Mode**, and **Intermittent Mode**.

In the **Transient Mode**, when the relay detects the transient, and the  $V_0$  level meets the **Voltage Start Value (Vs)** settings, the timing is activated. Timing continues until trip, or in case of a drop-off, the drop-off duration is shorter than the set **Reset Delay Time** setting.

In the **Intermittent Mode**, when the relay detects the transient, and the  $V_0$  level meets the **Voltage Start Value (Vs)** settings, the timing is activated. When a required number of intermittent earth-fault transients set with the **Peak Counter Limit** setting are detected, without the function being reset (depends on the drop-off time set with the **Reset Delay Time** setting), the trip output is activated.

**V<sub>0</sub> Signal Sel:** There are two mode settings. **Measured Mode** will provide the simulated  $V_0$  output from voltage channel V1, which requires the user to connect V1 to the  $V_0$  input terminal of the relay. The **Calculated Mode** means the relay will measure the three voltage inputs and calculate the  $V_0$  present. Therefore, the software will apply three channels of voltage output to the relay, with the simulated output generating the required  $V_0$ .

**Directional Mode:** The default setting is in the **FORWARD** direction. Pressing the button will present the user with two more selections, **REVERSE**, and **NON-DIRECTIONAL**. Selecting **REVERSE** will test the operating characteristic in the reverse direction. Selecting the **NON-DIRECTIONAL** will test dual characteristics, one in the forward and one in the reverse direction.

**Operate Delay Time:** Default time is five hundred ms. The relay will trip after **Operate Delay Time** and if the residual voltage meets the set **Voltage Start Value (Vs)** or higher.

**Voltage Start Value (Vs):** Default setting is  $0.2 \times V_n$ .

**Reset Delay Time:** Default time is five hundred ms. The **Reset Delay Time** starts to elapse from each detected transient (peak). The relay operation resets if time between transients is more than **Reset Delay Time**.

**Peak Counter Limit:** Default setting is two. The relay transient detector will determine when a transient peak is counted, and when the number of transients meets or exceeds this limit the relay operation will start. The maximum number the user can enter is seven. The **No. of Transient States** will automatically change in the **Test Settings** to match.

**Min Operate Current:** Default setting is  $0.01 \times I_n$ .

#### 3.5.9.2.2 Transient Earth-Fault Test Settings

**No. of Transient States:** Defaults to a setting of two. Enter the number of transients to be applied to the relay under test. This setting needs to equal, or exceed by one, the Peak Counter setting in the relay.

**Transient Fault Time:** Defaults to ten ms (ms). This is the time that the transient simulation will be applied.

**Peak Fault Current:** Default setting is  $5 \times I_n$ . This peak fault current will be applied for each transient.

**Peak Fault Voltage:** Default setting is  $5 \times V_n$ . This peak fault voltage will be applied for each transient.

**Inom (sy):** Default is 1 A. This is secondary Amperes. Enter the desired secondary value.

 Application Note: If using Primary Values see section 2.3.1.28, CT/PT Ratios for settings test values using primary values.

**Vnom (sy):** Default is 57.74 V. This is secondary volts. Enter the desired secondary value.

 Application Note: If using Primary Values see section 2.3.1.28, CT/PT Ratios for settings test values using primary values.

#### 3.5.9.2.2 Performing Transient Earth-Fault Test



##### Theory of Operation

Upon pressing or clicking on the TEF button, the user will note that the TEF sequence test is already set for testing a relay programmed to sense two transient earth faults, with an instantaneous trip operation upon sensing the second transient. If the relay is programmed for sensing multiple short intermittent transients associated with cable faults, the Peak Counter in the Relay Settings may be set as high as seven, and the TEF test will automatically set the additional transient states.



With the Peak Counter default value of 2, if the Operating Time is set at 500ms, the Sequencer TEF test will generate two peaks within five hundred ms. With the Reset Time set at five hundred ms, with the first peak set at 10ms, and the second peak programmed to appear at 480 ms, the relay should operate instantaneously upon sensing the second peak transient.





1. Press or click on the TEF button.
2. Enter the Relay Settings.
3. Enter the appropriate **Transient Fault Time** in the **Test Settings** window.

 Application Note: For cable fault simulations, the relay may be set to sense Intermittent Earth Faults. Make sure you set the appropriate Transient Fault Time for simulating intermittent faults.

4. Set appropriate **Peak Fault Current** and **Peak Fault Voltage** values in the **Test Settings**.  
 Application Note: The default values are usually sufficient but may need adjustments.
5. Enter the appropriate system **I nom** and **V nom** values in the **Test Settings**.  
 Application Note: Some relays are set in Primary values, see section 2.3.1.23 CT/PT Ratios for settings test values using primary values.
6. Press or click on the green check button. Depending on the **V0 Signal Setting**, the software will instruct the user to connect the test set voltage channel V1 to the relay V0 input terminal (for Measured V0), or V1, 2, and 3 to relay inputs V1, 2, and 3 (for Calculated V0). The user will also note that the software automatically selected either V1 for Measured, or all three voltage channels for Calculated.
7. Connect the relay trip contacts the Binary Input #1. The user should note that the binary input is programmed for Normally Open contacts to close. If the trip contacts are something other than normally open dry contacts, see programming of binary inputs. The relay is now ready to test.
8. Press or click on the blue Run Test button to execute the test.
9. Press or click on the Report Options button to review and save results.

### 3.6 Testing Impedance Relays

There are three methods provided in RTMS. The method providing the most flexibility and complete test capability is the Click on Fault (CoF) represented by the  button. The second method is referred to as Easy Z represented by the  button, providing a more manual approach to performing basic impedance relay tests. For testing impedance relays with unknown or undefined characteristics press the third  button. The first method discussed will be the Click On Fault.

Press the Select New Test button  to get access to the Impedance Relay Click On Fault. Then press the  Impedance Relay Click on Fault button. Select from; the Relay Library  Button, or the MCE/RIO  Button. Pressing the **Relay Library** will provide a library of relay specific characteristics by various manufacturers as well as Generic. Pressing the **Generic** button will provide a library of generic impedance relay characteristics to choose from. Pressing the **MCE/RIO** button, characteristics that exist in Megger Characteristic Editor/RIO file formats may also be imported and used in the COF Test Screen. Pressing the predefined test  button, the user can select from a list of predefined impedance relay tests that were previously saved to the database.

#### 3.6.1 Common Settings

The following settings are common to both Generic and Relay Specific from the Relay Library.

### 3.6.1.1 Tolerance Settings

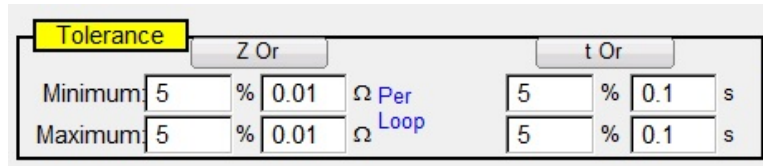
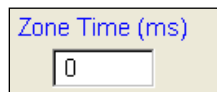

Figure 164 Tolerance Settings Dialog Box

Enter Maximum and Minimum Percentages or enter the maximum and minimum Ohmic and Time values for Pass / Fail evaluation of the test results. Z = % of Impedance in Ohms, and Time values are in % of Expected Trip Time setting. Press on the **Z Or**, and/or the **t Or** button, and the buttons will change to read **Z Plus** and **t Plus**, which will be a summation of the two values. When performing pickup tests using Pulse Ramp if a time is entered into the Expected Trip Time window the software will record the trip time as well as the pickup value.

**Application Note:** To save time, if the tolerance is the same for all zones, enter the tolerance values once, then press the **Copy Zone**, then press the **Paste to All Zones**.

### 3.6.1.2 Zone Trip Time Settings



Enter expected trip time for each Zone of operation. Settings are defaulted in ms. To change to Cycles, click on the **ms** and it will change to **cy** for Cycles. When conducting reach tests using Pulse Ramp the software will capture the operating time of the pickup and compare it to the expected trip time and provide pass/fail indication.

### 3.6.1.3 DIRECTION Setting Button

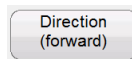

The default setting is in the FORWARD direction. Pressing the button will present the user with four selections, OFF, FORWARD, REVERSE, (and with QUAD, NON-DIRECTIONAL). Selecting REVERSE will flip the operating characteristic over in the reverse direction. For QUAD test applications, selecting the NON-DIRECTIONAL will create dual characteristics for the selected zone, one in the forward and one in the reverse direction.

### 3.6.1.4 Zones/Fault Selection Box



Figure 165 Zone and Fault Type Selection Dialog Box

The user can select which Zone they wish to define, with up to 20 Zones selectable. When more than one Zone is defined; to view multiple zones all in the same graphic window press the  multi-zone display button. When pressing the icon, the background color will change, and you will see the multiple zones displayed in the impedance plane display. Touch the window again and it will return to single zone display format. The user can define **LL**- Phase to Phase fault, **3P**- 3 Phase Fault, or **LN**- Phase to Ground fault.

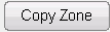
**Application Note:** To save time, enter the reach and angle settings once. Then, use the Copy Zone  button. Select one of the other fault types and press the Paste Zone button and all the values entered for the previous fault type will be entered for the other fault type. Note this should be limited to only same zone fault types. Selecting **LN** phase to ground will provide an additional button to enter the appropriate Ground Compensation factors, see Ground Compensation Settings.

### 3.6.1.5 Ground Compensation Settings



When a single-phase fault is selected, the Ground Compensation button will appear. In the Generic screen there are several types of compensation factors to choose from depending on the type of impedance characteristic.

For MHO and Half MHO, **KN** and **Z0Z1** are available.

Residual compensation factor, KN, is a complex number that is used to express the earth-return impedance, ZN, in terms of the positive-sequence impedance reach setting, Z1. This factor is calculated as:

$$\mathbf{KN} = \mathbf{Z_N/Z_1} = (\mathbf{Z_0 - Z_1})/(3\mathbf{Z_1})$$

Where: Z0 is the zero-sequence impedance polar reach of the zone

**Z0Z1** Ratio = the complex ratio of Z0/Z1, also referred to as **K0=Z0/Z1**

For QUAD (quadrilateral) there are: **KN**, **Z0Z1**, **RE/RL** **XE/XL** and **R0 X0 R1 X1**.

**RE/RL** **XE/XL** is a pair of scalar factors. These factors affect the resistive reach and reactive reach of some polygon characteristics.

$$\mathbf{RE/RL} = (\mathbf{R_0/R_1 - 1})/3$$

$$\mathbf{XE/XL} = (\mathbf{X_0/X_1 - 1})/3$$

#### **R0 X0 R1 X1**

Where:

R1 = real part of Z1

X1 = imaginary part of Z1

R0 = real part of Z0

X0 = imaginary part of Z0

Press the Ground Compensation button and the following settings window will appear.



Figure 166 Ground Compensation Settings Dialog Box

The default screen is for KN. To select other compensation values, press the Type (KN) button. Where the compensation factors are part of the relay settings (such as the Relay Library AREVA Quadramho) the Compensation button will not be provided, but the values will be calculated based upon the actual relay settings. Enter the magnitude and angle for the appropriate compensation value, and RTMS will calculate the relay operating characteristic and appropriate test values in the test window.

### 3.6.1.6 CT PT Ratios

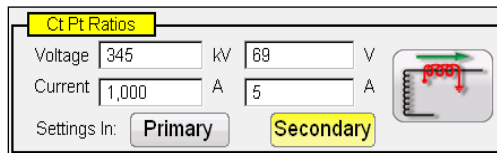

The Primary and Secondary buttons control the scaling in the impedance graph and are associated with the CT and PT values entered. Enter the appropriate primary and secondary values. Press either the Primary or Secondary buttons and the ohmic scaling will change in the impedance graph. The polarity of the CT can also be set in this window.

### 3.6.2 Generic Characteristics

Pressing the Generic Characteristics button will provide four options, MHO, Half Circle, QUAD (Quadrilateral), and IEEE QUAD.

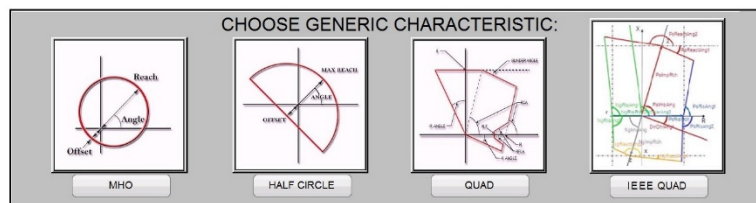

Selection of the MHO will provide the Generic MHO Setting Screen.

### 3.6.2.1 Generic MHO Setting Screen

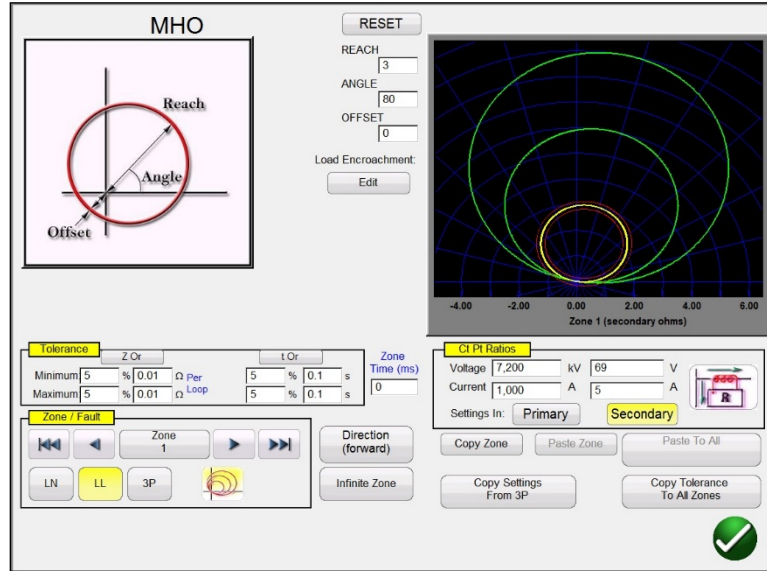

Figure 167 Generic MHO Setting Screen

There are three basic settings; REACH, ANGLE, and OFFSET that will define the relay operating characteristic. REACH is a value in Ohms. ANGLE is a value in degrees normally associated with the maximum torque angle, line, or characteristic angle setting of the relay. OFFSET is a value in Ohms indicating either positive or negative offset. Pressing the Load Encroachment Edit button will reveal the Load Encroachment settings screen.

#### 3.6.2.1.1 MHO Load Encroachment Setting Screen

For relays with Load Encroachment characteristics in the longer reaching zones of operation, pressing the Load Encroachment Edit button will reveal an appropriate settings dialog box.

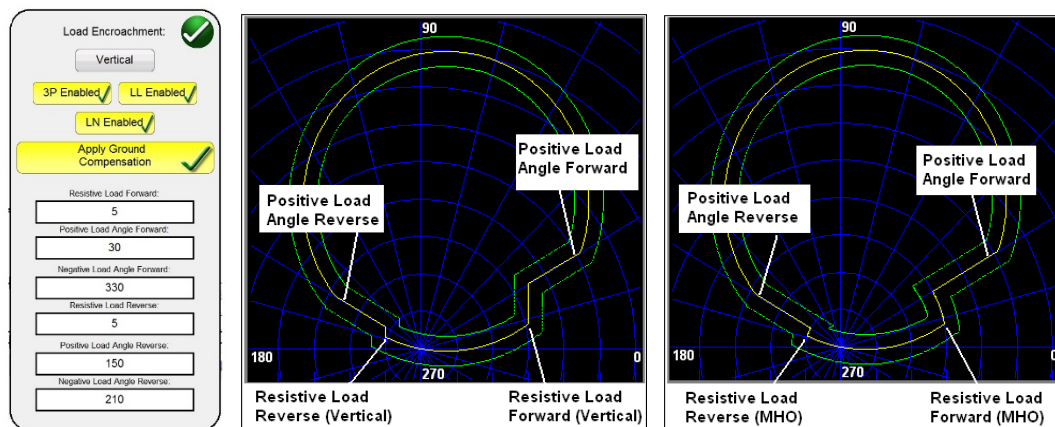

Figure 168 Load Encroachment Settings and Examples (Vertical, MHO)

The setting screen defaults to MHO characteristic. Press the Vertical button to select for a Vertical characteristic. To enable selective fault types, press the appropriate button. It will change to yellow background and a checkmark will appear in the box. Enter the appropriate ohmic values and angles to achieve the desired characteristic.

### 3.6.2.2 HALF CIRCLE Setting Screen

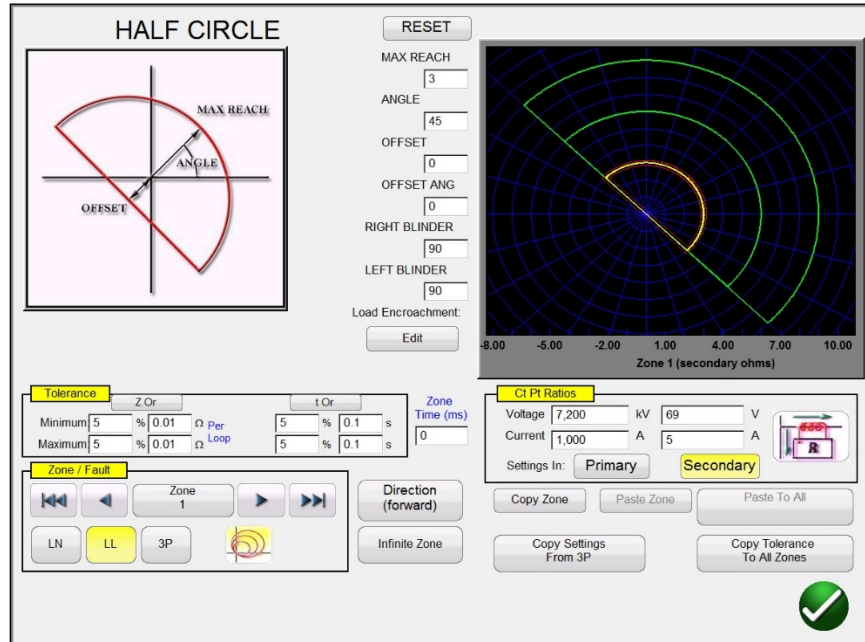

Figure 169 Half MHO Setting Screen

There are six basic settings; MAX REACH, ANGLE, OFFSET, OFFSET ANGLE, RIGHT BLINDER, and LEFT BLINDER that will define the relay operating characteristic. MAX REACH is a value in Ohms. ANGLE is a value in degrees normally associated with the maximum torque angle, line, or characteristic angle setting of the relay. OFFSET is a value in Ohms indicating either positive or negative offset. OFFSET ANGLE is a value in degrees, which may be different from the ANGLE setting. This setting is normally associated with the directional offset mho setting. RIGHT BLINDER and LEFT BLINDER are values in degrees associated with blinder elements along the right and left sides of the original half MHO characteristic and are angles relative to the ANGLE setting (note the default of 90 degrees or a right angle relative to the ANGLE setting). Any MHO/OHM type characteristic can be molded using a combination of the BLINDER values ranging from pie shape to something greater than a Half MHO up to an OHM characteristic.

### 3.6.2.3 QUAD Setting Screen

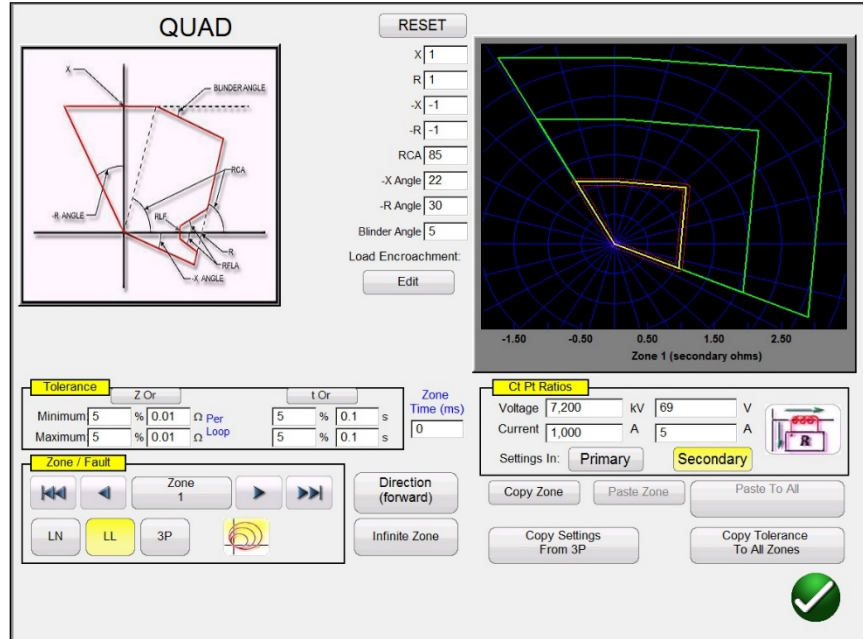

Figure 170 Generic QUAD Setting Screen

There are eight basic settings; X, R, -X, -R, RCA, -X Angle, -R Angle, and Blinder Angle that will define the relay operating characteristic. X and R are values in Ohms associated with the X and R axis, in an RX Impedance plane. The R value is normally referred to as the Positive Resistive Reach. The X value is normally referred to as the Positive Reactance Reach. The -X and -R are values in Ohms associated with -X and -R setting when the DIRECTIONAL setting is either set to NON-DIRECTIONAL or REVERSE settings. The -R value is normally referred to as the Negative Resistive Reach, and the -X value is normally referred to as the Negative Reactance Reach. The RCA is a value set in degrees normally associated with the maximum torque angle, line angle, or positive impedance characteristic angle setting of the relay. The -X and -R Angles are values in degrees normally associated with the Directional Characteristic Angles. Blinder Angle is a value in degrees, sometimes referred to as the Tilt Angle or a variant of the Positive Reactance Angle.

#### 3.6.2.3.1 QUAD Load Encroachment Setting Screen

For relays with Load Encroachment characteristics in the longer reaching zones of operation, pressing the Load Encroachment Edit button will reveal the following settings dialog box.

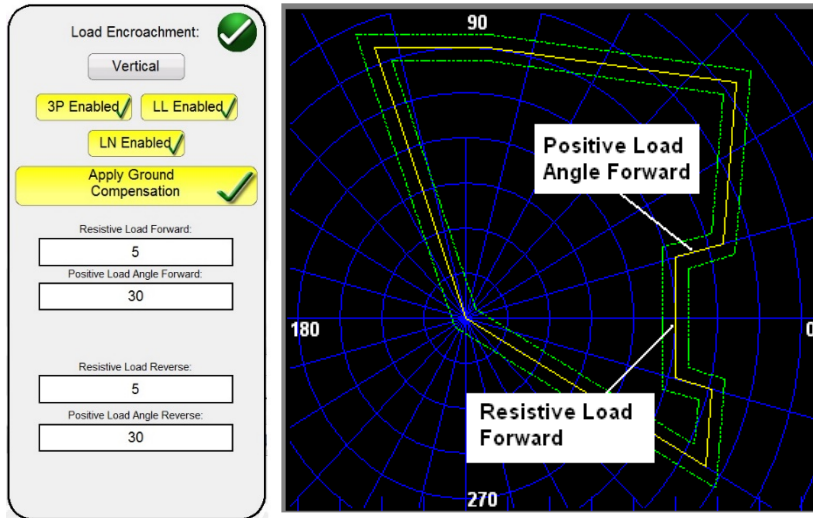

Figure 171 Example Load Encroachment Setting Screen for Generic QUAD

To enable selective fault types, press the appropriate button. It will change to yellow background and a checkmark will appear in the box. Enter the appropriate ohmic values and angles to achieve the desired characteristic.

### 3.6.2.4 IEEE QUAD Setting Screen

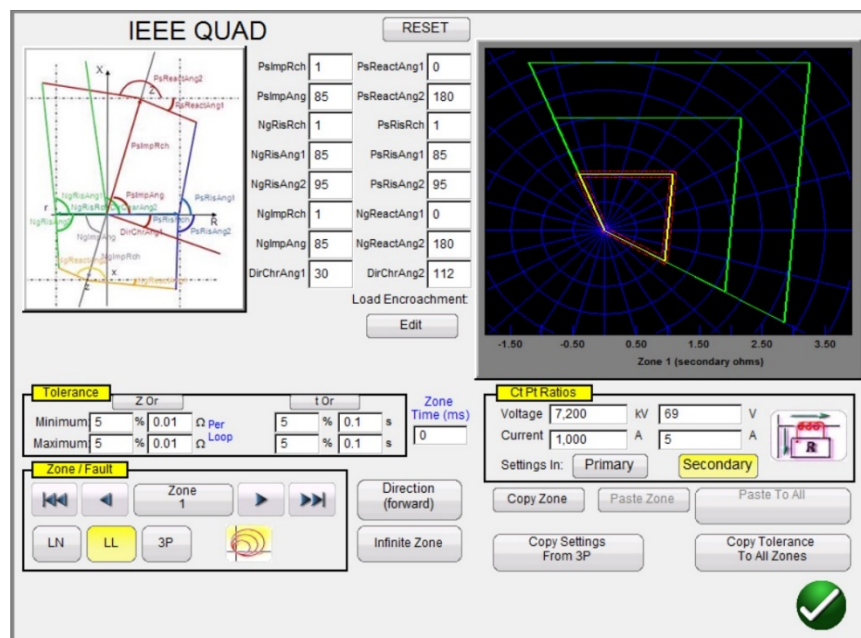

Figure 172 Generic IEEE QUAD Setting Screen

Sixteen settings can be used to define any impedance relay polygon (QUAD) characteristic. The following are the characteristic nomenclatures and definitions.

**PsImpRch** Positive Impedance Reach - defines the positive reach in Ohms representing the line impedance.

**PsImpAng** Positive Characteristic Angle – this is the line impedance angle in the forward direction (first quadrant). This angle is measured counterclockwise from the positive R-axis.

**PsReactAng1** Positive Reactance Angle 1 to the right of the line impedance This angle is measured clockwise from the horizontal line going through the reactive reach on the X-axis. The area above the line is excluded from the operating area.

**PsReactAng2** Positive Reactance Angle 2 to the left of the line impedance. This angle is measured counterclockwise from the horizontal line going through the reactive reach on the X-axis. The area above the line is excluded from the operating area.

**PsRisRch** Positive Resistive Reach – defines the positive resistive reach to limit the coverage for fault resistance and at the same time to limit the encroachment of the load impedance into the characteristic. The setting determines the reach on the R axis.

**PsRisAng1** Positive Resistive Angle in the first quadrant. This angle is measured counterclockwise from the R-axis. The area right from the blinder is excluded from the operating area.

**PsRisAng2** Positive Resistive Angle in the fourth quadrant. This angle is measured clockwise from the R-axis.

**NgRisRch** Negative Resistive Reach – defines the negative resistive reach. The setting determines the reach on the R axis.

**NgRisAng1** Negative Resistive Angle 1 in the second quadrant. This angle is measured counterclockwise from the R-axis. The area left from the blinder is excluded from the operating area.

**NgRisAng2** Negative Resistive Angle 2 in the third quadrant. This angle is measured counterclockwise from the R-axis. The area left from the blinder is excluded from the operating area.

**NgImpRch** Negative Impedance Reach – defines the impedance reach in the reverse direction.

**NgImpAng** Negative Characteristic Angle – this is the impedance angle in the reverse direction (third quadrant). This angle is measured counterclockwise from the positive R-axis.

**NgReactAng1** Negative Reactance Angle 1. This angle is measured clockwise from the horizontal line going through the negative reactance reach on the X axis. The area below the line is excluded from the operating area.

**NgReactAng2** Negative Reactance Angle 2. Negative This angle is measured clockwise from the horizontal line going through the negative reactance reach on the X axis. The area below the line is excluded from the operating area.

**DirChrAng1** Directional Characteristic Angle 1 – this is the directional characteristic angle in the fourth quadrant. This angle is measured counterclockwise from the positive R-axis.

**DirChrAng2** Directional Characteristic Angle 2 – this is the directional characteristic angle in the second quadrant. This angle is measured counterclockwise from the positive R-axis.

#### 3.6.2.4.1 IEEE QUAD Load Encroachment Setting Screen

For relays with Load Encroachment characteristics in the longer reaching zones of operation, pressing the Load Encroachment Edit button will reveal the following settings dialog box.

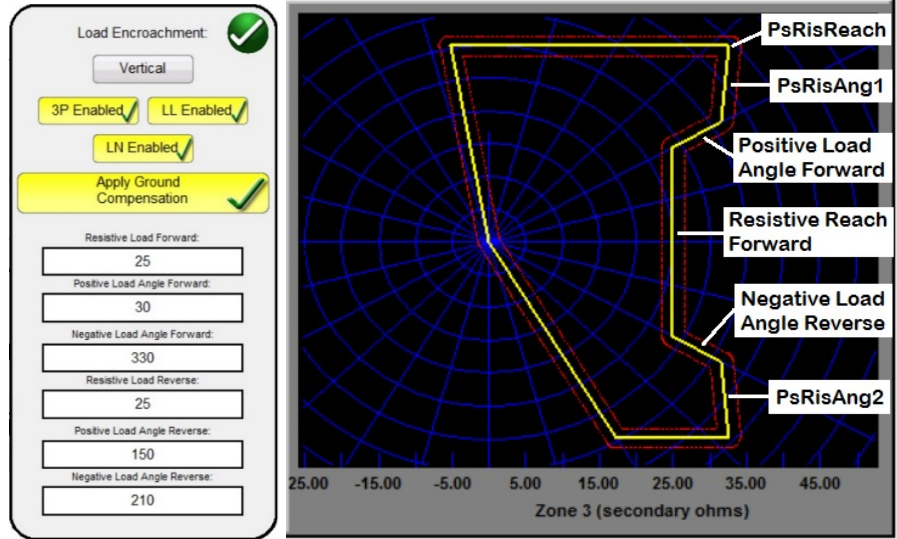

Figure 173 Example Load Encroachment Setting Screen for Generic IEEE QUAD

To enable selective fault types, press the appropriate button. It will change to yellow background and a checkmark will appear in the box. Enter the appropriate ohmic values and angles to achieve the desired characteristic.

### 3.6.3 Impedance Relay Library Files

Pressing the Impedance Relay Library  button will provide a selection window containing relay specific impedance characteristics listed by relay manufacturer and Model identifier. Future software updates will include more relay specific library files; see Upgrading RTMS for more information on downloading RTMS from the Megger website.

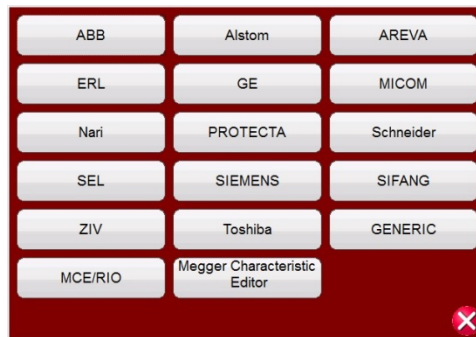

Figure 174 Relay Library Selection Screen

RTMS supports the import of relay settings in various file formats; see section 3.1.6, Relay Settings Import. Relay setting import files supported in the Impedance Relay Test are Read From Relay SEL Serial or GE Modbus, XRIO, TEAX, SEL RDB, ERL L-PRO, XML, and RTMS CSV files. If you do not have the relay settings in one of the previously mentioned file formats, enter the relay manufacturer's settings manually and the operating characteristic will be created from the settings entered. Note that

specific relays have different characteristics depending on user input. Where a relay may have multiple characteristics, selection buttons are provided to choose from. For example, the Schweitzer model SEL 311 and General Electric UR D60 relays have a selection for either Mho or Quad characteristics. In the SEL 311 characteristic setting screen you have the added choice of Mho + Quad. The setting nomenclatures change with the selection of either Mho or Quad, and either Phase to Ground or Phase to Phase selections.

#### 3.6.4 MCE/RIO Files

Pressing the **MCE/RIO** button will provide a selection window which may contain specific relays listed by relay manufacturer and/or Model identifier<sup>2</sup>.

The Megger Characteristic Editor, MCE, is a tool for creating impedance relay operating characteristics using combinations of Lines, Arc's, and/or MHO circles, see section 3.6.9. Impedance characteristics created using the MCE can be imported into the Click on Fault test screen, tested, and results saved. Impedance settings can be changed in the MCE for testing the same type of relay.

Various manufacturers create RIO files using relay, or relay test software. They may be Relay Impedance Objects but are also allocated to other characteristics such as families of time-amplitude. RIO files constitute data for the characteristics of a particular relay with specific settings. Some or all the characteristic types may be created in the file and the characteristic relay settings will be included. I.e., the RIO files are relay **specific to the settings** of the relay when the RIO file is created; the discrete settings are neither displayed nor adjustable. If the settings are changed, a new RIO file will need to be created to test the relay. Once the relay is selected it will take the user to the Click on Fault Configuration Screen.

#### 3.6.5 Impedance - Click on Fault Configuration Screen

After selection of either a Generic or a Library relay specific impedance characteristic and entering the appropriate impedance settings for each of the specific Zones to be tested, press the green check button, which will take the user to the Click on Fault Configuration Screen.

---

<sup>2</sup> Requires user to import the desired RIO files, in advance, into a RIO file folder under the MY Documents/PowerDB directory. Impedance characteristics developed using the Megger Characteristic Editor can be saved to the same directory.

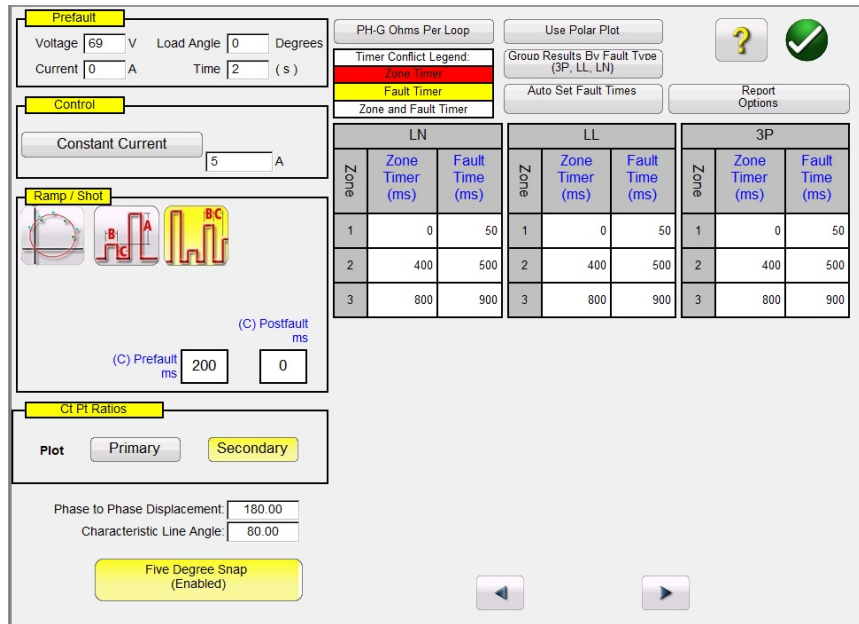

Figure 175 Impedance Relay, Click on Fault Configuration Screen

### 3.6.5.1 Prefault Dialog Box

The prefault values will be applied to the relay under test prior to ramping. If using Pulse Ramp the prefault values will be applied between each pulse increment. The *Prefault Dialog box* contains four edit fields:

- Voltage** – Enter a value of Voltage to be set.
- Current** – Enter a value of Current to be set.
- Load Angle** – Enter a value for a Load Angle to be set.
- Time** – Enter the desired time prior to applying the first test point.

### 3.6.5.2 Control Dialog Box

This dialog box provides the user with a selection of different methods to perform the tests. Some manufacturers require Constant Voltage and ramp current, some require Constant Current and ramp voltage. In addition, the user may also select Constant Source Impedance.

**Constant Voltage** - Enter the value of volts to be held constant for all Fault Types tests under execution, default value is 5.0.

**Constant Current** - Enter the value of current to be held constant for all Fault Types tests under execution, default value is 1.0.

**Constant Source Z** - There are two forms of Source Impedance; Ohms and Angle, or R and X. Enter the value of ohms and the angle of the source to be held constant for all Fault Types tests under execution or enter the R and X values where.

- R:** the Cartesian resistive equivalent of the impedance **[Z]** and its angle **Phi**
- X:** the Cartesian reactive equivalent of the impedance **[Z]** and its angle **Phi**

### 3.6.5.3 **Ramp/Shot** Options

This dialog box provides three different ways to determine the operating characteristic of impedance relays. Shots are used to create one or more test points to replicate a fault at a particular magnitude and angle. *Trip (inside the operating characteristic) and/or No-Trip (outside the operating characteristic)* points may be selected for each Fault Type. Selection of the type of Ramp is dependent on the relay. To test multi-Zone relays, use either the Pulse Ramp or Pulse Ramp Binary Search. The software will automatically calculate the increment required in V, I, and phase angle. The Pulse Ramp and Pulse Ramp Binary Search also include a Prefault setting in ms. This is the time that the pre-fault values will be applied between fault increments.

### 3.6.5.4 **CT PT Ratios**

This dialog box provides user selection for plotting the operating characteristic in either Primary or Secondary Ohms.

### 3.6.5.5 **Polar/Rectangular** Plot Button

This dialog box provides user selection for plotting the operating characteristic in either Polar or Rectangular coordinates.

### 3.6.5.6 **Auto Set Fault Times** button

This button works in conjunction with the Zone Timer settings window. You can change the Zone Trip and Fault Times by Pressing or clicking the appropriate setting window for the selected Zones. Pressing the Auto Set Fault Times button will automatically set the amount of time the fault will be applied to the relay. The Fault time is set in ms, and automatically set to a value higher than the Expected Trip Time (just long enough for the zone being tested to operate, but not for other zones).

### 3.6.5.7 **Ohms Per Phase/Per Loop** button

This button works in conjunction with the Click on Fault Test Screen. For relays that use Loop Impedance Zero Sequence Compensation, press this button to read Ohms Per Loop to change the display to represent Ohms Per Loop. Note that for relays with imported settings this window could be grayed out.

### 3.6.5.8 **Report Options** button

This button allows the user to select what is displayed in the test report in terms of % error and Z/t timing results.

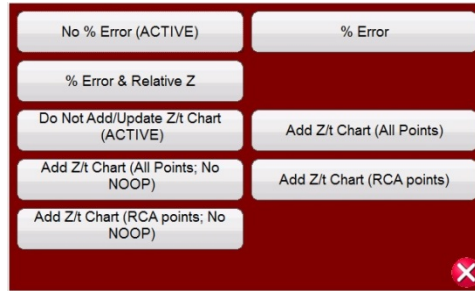

Figure 176 Report Options Selection Menu

- % Error** – Adds the % error of the selected test in the test screen and to the report page.
- No % Error (ACTIVE)** – Removes the % error from the selected test and from the report.
- % Error & Relative Z** – Recalculates the Theoretical Z and % Error based on Relative Z.
- Add Z/t Chart (All Points)** – Add relay operating times with zone impedance for all test points.
- Add Z/t Chart (RCA Points)** – Add relay operating times with zone impedance for RCA test points.
- Add Z/t Chart (All Points, No NOOP)** – Add relay operating times with zone impedance for all test points, do not include NOOP points.
- Add Z/t Chart (RCA Points, No NOOP)** – Add relay operating times with zone impedance for RCA test points, do not include NOOP points.

### 3.6.5.8.1 Adding Z/t Chart to Report

The Z/t Chart button allows the user to select to view the Z/t time chart, with different configurations, in the test results. See the following example test result where the three phase Z/t times are plotted.

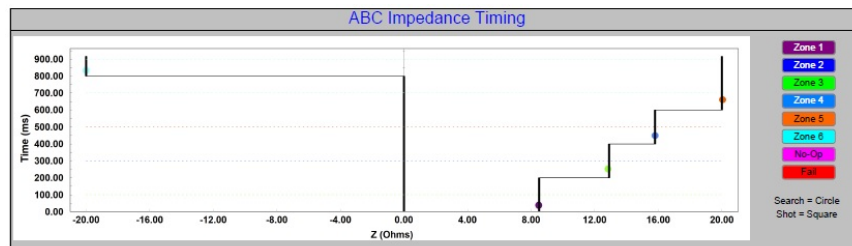

Figure 177 Relay operating time vs. zone impedance.

### 3.6.5.9 Five Degree Snap button

Pressing or clicking on the button will enable the Five Degree Snap when selecting a test point near the maximum angle of torque/characteristic line angle in the Click on Fault test screen. It will create a test starting point either at the line angle or within 5 degrees of the line angle.

### 3.6.6 Impedance - Click on Fault Test Screen

After selection of either a Generic or a Library relay specific impedance characteristic and entering the appropriate impedance settings for each of the specific Zones to be tested, press the green check button, which will take the user to the Click on Fault Test Screen.

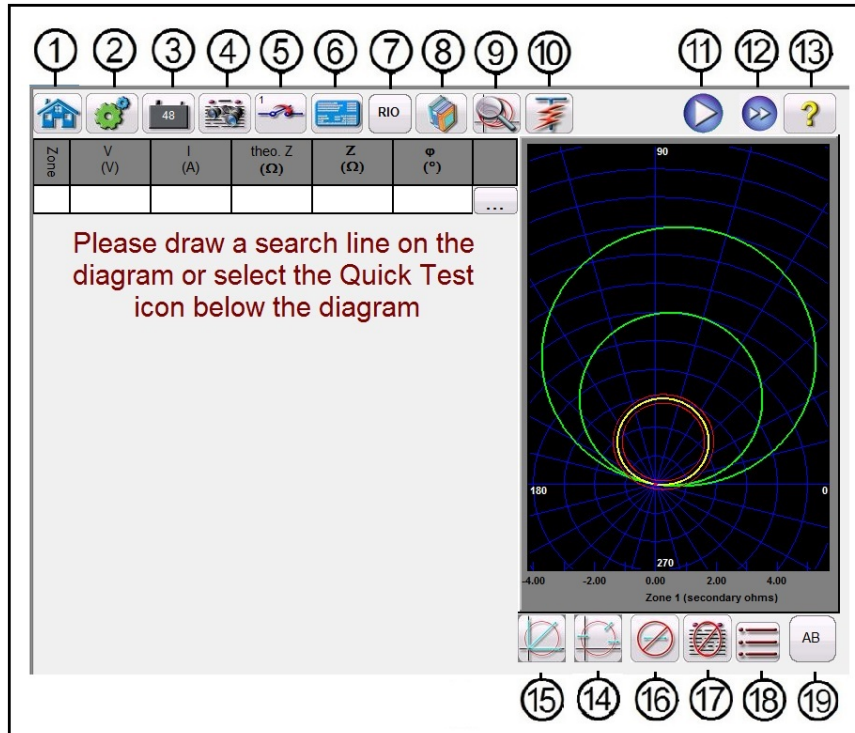



Figure 178 Impedance Relay, Click On Fault Test Screen

3.6.8.7.1 ① Home button 

Pressing the home button will return you to the manual test screen.

3.6.6.2 ② Configuration button 

Press the button to go to the STVI Configuration Screen. See Section 2.2.1 Configuration for more information about the Configuration Screen.

3.6.6.3 ③ Battery Simulator button 

The Battery Simulator button – Turns the Battery Simulator ON and OFF by pressing the button, the color changes red for ON and black for OFF. The voltage to be applied is displayed in the button and can be changed by pressing the configuration button.

3.6.6.4 ④ Review Test Report button 

Press this button to review the test results.

### 3.6.6.5 ⑤ Binary Input Setting button

Press this box to reveal the Binary Input Dialog box.

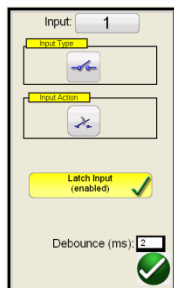

The default settings are Binary Input 1, dry contacts as indicated by the Input Type, and Input Action defaults to show the Closing of the Normally Open contacts. To change the Input Type from dry contacts to Voltage, press the Input Type icon, and it changes to voltage. To change to the opening of Normally Closed contacts press the Input Action icon and it changes to show closed contacts opening. For timing the operating time of the impedance element, the timer is defaulted to Latched Input enabled mode, which means the timer will stop on the first contact closure. Note the Debounce time is set to 2 ms.

### 3.6.6.6 ⑥ Relay Settings Button

Press this button to access selection of the Relay's Settings Screen. Here the user can adjust parameters.

### 3.6.6.7 ⑦ RIO button

Pressing the RIO button will provide a selection window containing specific relays listed by relay manufacturer and Model identifier<sup>3</sup>.

### 3.6.6.8 ⑧ Relay Library button

Pressing the Relay Library will provide a library of relay specific characteristics by various manufacturers. Pressing the Generic Characteristics button will provide a library of generic impedance relay characteristics to choose from.

### 3.6.6.9 ⑨ Zone Zoom button

Pressing this button will zoom in on the selected zone. Press it again and return to the normal test screen mode.

---

<sup>3</sup> Requires user to import the desired RIO files, in advance, into a RIO file folder under the MY Documents/PowerDB directory.

3.6.6.10 ⑩ Run Predefined Test button 

Pressing the Run Predefined Test button provides access to Predefined test plans, created by either Megger or users, in Pdb Tst file structure.

3.6.6.11 ⑪ Run Test button 

Pressing or clicking the blue Run Test button will apply the Prefault vector for the specified Time, then step to the Fault values and look for the relay under test to operate using either a Pulse Ramp or Pulse Ramp Binary Search. Pressing this button will play all the selected test points for the selected fault type, for all the selected zones.

3.6.6.12 ⑫ Test All button 

Press the Test All button to automatically sequence through all defined tests, Phase to Ground, Phase to Phase, and Three Phase, for all zones.

3.6.6.13 ⑬ Help button 

The Help button is sensitive to the test and will take the user to this section of the manual. It can also be used to reset the unit.

3.6.6.14 ⑭ Change Search Mode button 

There are three modes to choose from, Auto Generate, IEC 60255, and Origin Test Points. In the default auto generate mode the user may select any test line, at any angle, around the operating characteristic by clicking at a point outside and then inside the operating characteristic(s) to define the desired test line. When you select the first test line, the Auto Generate test point's  button will appear. Press this button to reveal the auto generate test point options.

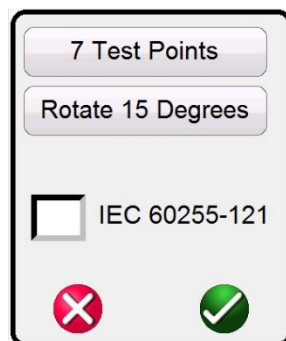



Figure 179 Test Points Selection Screen

The user may select the desired number of test points by pressing the Test Points button and select from the list. Then the user may select the desired phase rotation between the selected number of test points by pressing the Degrees to Rotate button. If none of the standard phase rotations meets the user's needs, press the Degrees to Rotate button in the list and enter the desired phase rotation in the window provided.

Press this button again to reveal the IEC60255 Test Points Mode. Press this button a third time to reveal the Origin Test Points Mode.

3.6.6.14.1 IEC60255 Test Points Mode 

The IEC60255 Test Points option- In accordance with IEC 60255 standard click a point outside, then inside, the operating characteristic and the test line will be drawn perpendicular to the operating characteristic line. Press this button to reveal the Origin Test Points option.

3.6.6.14.2 Origin Test Points Mode 

The Origin Test Points option - Click a point outside the operating characteristic and the test line will be drawn to the origin or the intercept of the R and X-axis. Press this button to return to the auto generate mode.

3.6.6.14.3 Shots Test Points option 

The Shots Test Points option – Used to create one or more points of test, each to replicate a fault at a particular magnitude and angle. *Several Trip (inside the operating characteristic) and/or No-Trip (outside the operating characteristic)* points may be selected for each Fault Type. The **Test Point** is the set of values listed both in Mag and Phase Angle, and in Cartesian values that are created in the Graph. Continued clicks will produce additional test points at the mouse locations. Note that when Test Points is selected, test points will be applied per the Impedance Configuration Settings screen, see 3.6.5.6 Auto Set Points Time. Also note that when you click on the Shots button % min max time windows appear, defaulting to +/- 5% of the time set in the Impedance Configuration Setting screen, see the following figure.

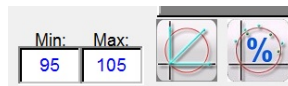

Figure 180 % Min Max Shots Time Settings

3.6.6.15  Quick Test – Auto Generate Test Points

Pressing or clicking on this button will provide the following selection menu.

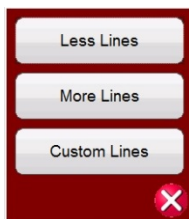



Figure 181 Quick Test - Auto Generate Test Line Options

Selecting Less Lines, three test lines will be drawn. One test line will be drawn at 0 degrees, another at 90 degrees, and one along the Line Angle setting in the Settings screen. Pressing or clicking on the More Lines button, up to nine test lines will be drawn. Any test line can be deleted and redrawn by the user as desired using the Run/Edit  button. Custom Lines allows the user to define three test line angles. Press the Run/Edit button for the individual test point. The user will then be presented with the following option screen.

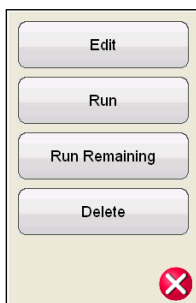

Figure 182 Run/Edit Button Options

The user can; Edit the start impedance values, Run the selected test individually, Run the Remaining tests, or delete the selected test. Press the red X to exit.

3.6.6.16  Clear Test Lines button

Press this button to clear tests from the selected test screen. Pressing this button will provide a list of user options as follows,

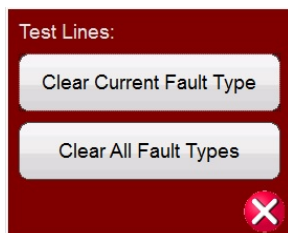



Figure 183 Clear Tests Options Screen

Clear Current Fault Type– Clears the currently selected test.

Clear All Fault Types: Clears all tests associated with the Fault.

 Note: There is no going back; once you clear a test there is no way to recover the tests unless you have saved the test to the internal memory.

3.6.6.17  Clear Results button

Press this button to clear test results. Pressing this button will provide a list of user options as follows,

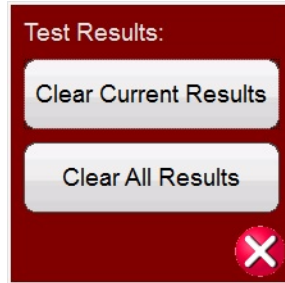



Figure 184 Clear Tests Options Screen

Clear Current Results– Clears the currently selected test result.

Clear All Results: Clears all test results associated with the test.

 Note: There is no going back; once you clear a test result there is no way to recover the test results unless you have saved the results to the internal memory.

3.6.6.18  Return to Characteristic Settings Screen button

Return to the relay characteristic setting screen button provides access back to the settings screen.

3.6.6.19  Fault Selection button

This button provides user selection of the desired fault to be defined. The choices are Phase to Ground, Phase to Phase, and Three Phase.

### 3.6.7 Easy Z Impedance Relay Test

Pressing the Easy Z Impedance Relay test button provides the testing of relays directly from the so called impedance plane, where the conversion from the impedance into voltages and currents is automatically done by RTMS.

Selection of the Easy Z  button will provide the following test screen.

### 3.6.7.1 Easy Z Impedance Relay Setting and Test Screen

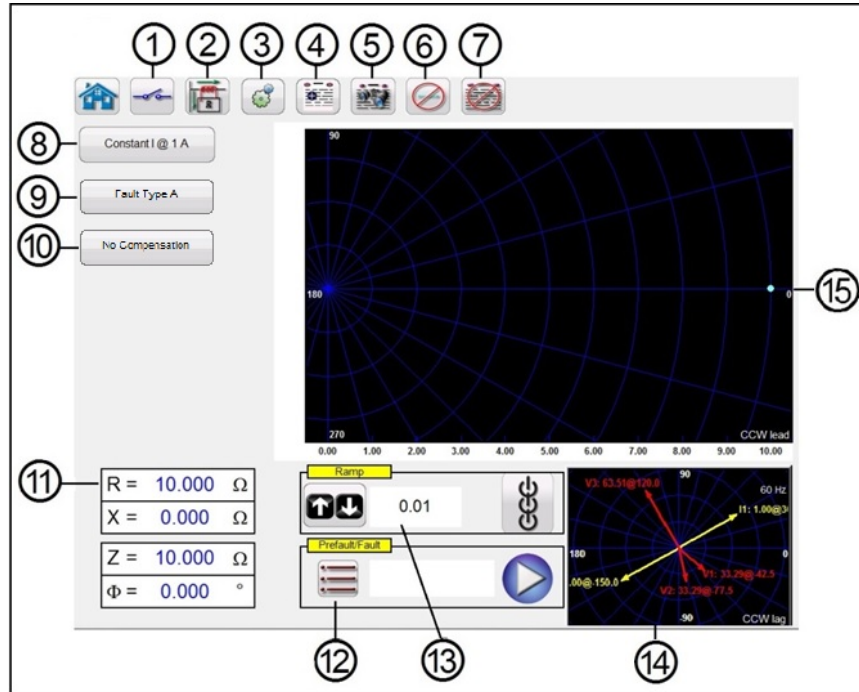
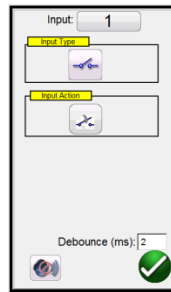

Figure 185 Easy Z Setting and Test Screen

#### 3.6.7.1.1 ① Binary Input Setting button



Press this box to reveal the Binary Input Dialog box.



The default settings are Binary Input 1, dry contacts as indicated by the Input Type, and Input Action defaults to show the Closing of the Normally Open contacts. To change the Input Type from dry contacts to Voltage, press the Input Type icon, and it changes to voltage. To change to the opening of Normally Closed contacts press the Input Action icon and it changes to show closed contacts opening. For timing the operating time of the impedance element, the timer is defaulted to Latched Input enabled mode, which means the timer will stop on the first contact closure. Note the Debounce time is set to 2 ms.

3.6.7.1.2 ② CT Earthing Position button 



If this button is selected, the simulated secondary current from test system will be in phase with the primary current, which flows from the bus bar into the protected line.



If this button is selected, the simulated secondary current from test system will be 180 degrees shifted compared to the same primary current used as reference. The two pictures below shows the output quantities from the test system for the same impedance of 10 ohms at 85 degrees, single phase to earth fault, with the two possible CT earthing combinations.

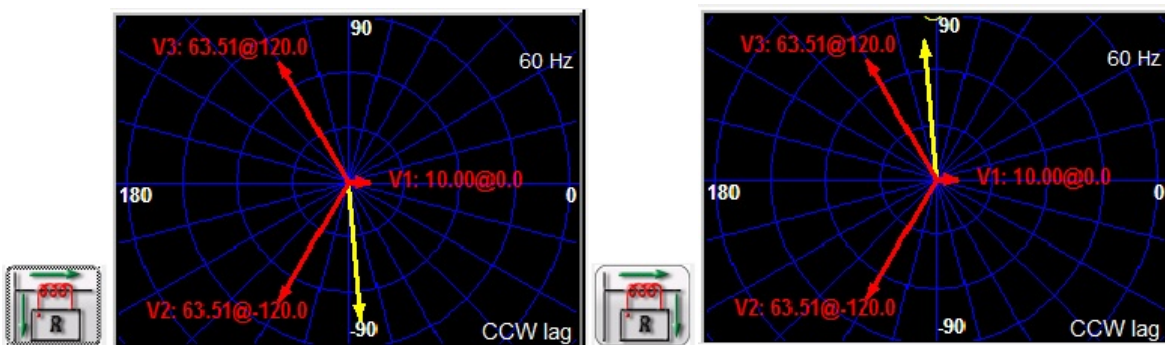

3.6.7.1.3 ③ The Configuration button 

Press the button to go to the Configuration Screen. See Section 2.2.1 Configuration for more information about the Configuration Screen.

3.6.7.1.4 ④ Report options button 

This button will add the present test result to the report. It also displays the report and allows the user to name the test, enter limits, comments, or deficiencies. Reports can be saved to the STVI, SMRT-D internal memory, and transferred to PowerDB via a USB memory stick. Previous tests results can be loaded, and the 'Retest' option can be used to repeat the test using the same parameters as the previous test.

3.6.7.1.5 ⑤ Review Test Report button 

Press this button to review the test results.

3.6.7.1.6 ⑥ Clear Test(s) button 

Press this button to clear tests from the selected test screen. Pressing this button will provide a list of user options as follows,

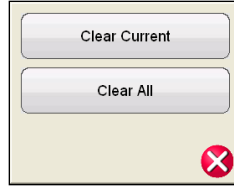

Figure 186 Clear Tests Options Dialog Box

Clear Current – Clears the currently selected test.

Clear All: - Clears all tests associated with the Fault.



Note: There is no going back; once you clear a test there is no way to recover the test unless you have saved the test to the internal memory.

#### 3.6.7.1.7 ⑦ Clear Test Results button

Press this button to delete test results.

#### 3.6.7.1.8 ⑧ Test Method Selection Box

This dialog box provides the user with a selection of two different methods to perform the tests. Some manufacturers require Constant Voltage and ramp current, some require Constant Current and ramp voltage. The voltage and current phasors, as function of the set impedance and method are calculated according to specification IEC 60255-121.

**Constant Voltage** - Enter the value of volts to be held constant for all Fault Types tests under execution. Default value is 5.0 V.

**Constant Current** - Enter the value of amperes to be held constant for all Fault Types tests under execution. Default value is 1.0 A.

#### 3.6.7.1.9 ⑨ Fault Type Selection button

This button provides user selection of the desired fault to be defined. The choices are Phase to Ground, Phase to Phase, and Three Phase. For phase to earth faults, the domain is the  $\Omega$ /loop domain. For the Phase-Phase and Three-Phase faults, the impedance is represented in the  $\Omega$ /phase domain.

#### 3.6.7.1.10 ⑩ Ground Compensation

When a single-phase fault is selected, the Ground Compensation button will appear.

For MHO and Half MHO, **KN** and **Z0Z1** are available.

Residual compensation factor, KN, is a complex number that is used to express the earth-return impedance, ZN, in terms of the positive-sequence impedance reach setting, Z1. This factor is calculated as:

$$KN = ZN/Z1 = (Z0 - Z1)/(3Z1)$$

Where: Z0 is the zero-sequence impedance polar reach of the zone

**Z0Z1** Ratio = the complex ratio of Z0/Z1, also referred to as **K0=Z0/Z1**

For QUAD (quadrilateral) there are: **KN, Z0Z1, RE/RL XE/XL** and **R0 X0 R1 X1**.

**RE/RL XE/XL** is a pair of scalar factors. These factors affect the resistive reach and reactive reach of some polygon characteristics.

$$RE/RL = (R0/R1 - 1)/3$$

$$XE/XL = (X0/X1 - 1)/3$$

**R0 X0 R1 X1**

Where:

R1 = real part of Z1

X1 = imaginary part of Z1

R0 = real part of Z0

X0 = imaginary part of Z0

3.6.7.1.11 ⑪ Fault Setting Fields

The Fault Setting Fields are where the value of the fault impedance is set by tapping on the field and entering the value with the keypad, or simply by tapping on the impedance plane window. It is possible to ramp with the knob any value of the fault impedance, see section "Impedance ramping".

3.6.7.1.12 ⑫ Pre-Fault, Fault, Post Fault dialogue box

Press the list  button to open the Prefault, Fault, Post Fault settings dialog box.

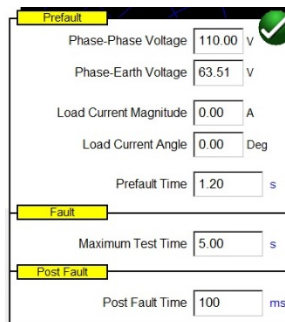



Figure 187 Prefault, Fault and Post Fault Settings box.

Enter the conditions for the Prefault and Fault test. Enter the Phase-Phase, or Phase-Earth voltage, Load Current, and Load Current Angle, along with the Prefault Time.

 Application Note: It is recommended to use Prefault current = 0 when testing distance protection relays, as the simulated power system is a radial feeder without any superimposed load, hence the simulation of the load current that will vanish during the fault condition is not a realistic representation of the power system. Also, if you set the prefault **and** post fault time to zero, you can conduct the test manually by simply clicking in the test window.

Set the Fault Maximum Test Time. Upon pushing the Blue Run Test button, the fault will be applied to the relay until the relay operates, or the Maximum Test Time expires.

Set the Post Fault Time. If the relay operates, faulty quantities are still injected for the Post Fault Time setting (in the example one hundred ms) simulating circuit breaker opening time. After that the injection is stopped and the operation time is reported. If the relay does not operate, after Maximum Test Time setting expires (in the example 5 s) the fault injection is stopped and the result is given as “NOP” (No Operation).

Pressing or clicking the blue play  button will apply the Prefault vector for the specified Time, then step to the Fault values and look for the relay under test to operate.

### 3.6.7.1.13 Impedance Ramp box

Here you can ramp in the impedance plane by using the control knob, the up down arrow keys on the PC, or the mouse control wheel. Press or click on the control wheel icon and the Impedance Ramp Selection box will appear. You can select the value to be ramped, Z, Phi, R or X and the increment size.



Figure 188 Impedance Ramp Selection box.



There are two types of ramps, pseudo-continuous ramp, or ramp of shots. The two ramp types may give different results, as in principle they implement two completely different testing methods. It is recommended to follow the relay manufacturer recommendation for the choice of the test method.

#### **Pseudo-continuous ramp**

Traditionally this is the method that is used to test the so called “static accuracy” of the relay, as the injected quantities will slowly change.

1] The pseudo-continuous ramp is activated by setting ZERO seconds for the Maximum Test Time in the pre-fault and fault settings.

2] Any parameter of the impedance can be manually slowly changed from the control knob, or up down arrows/mouse wheel on the PC. The parameter is chosen by tapping on it and selecting “Include Channel in Ramping” from the numerical keypad.

3] The step increment (or decrement) is chosen by pressing or clicking on the control wheel icon button.

4] The generation is activated by the ALL ON/OFF  button

When relay starts or operates, the injection is stopped (if the binary input is used to stop the ramp).

Application Note: Make sure the time interval between the two steps is larger than the operating time of the zone being tested.

### **Ramp of shots (step ramp)**

This method is not intended to test the static accuracy of the relay, as quantities are not slowly changed, but it is a good method to rapidly verify relay zone border settings without need to disable other distance protection zones, which is a common problem when using the pseudo-continuous ramp. This ramp is a succession of pre-fault and fault sequences.

1] The ramp is activated by setting the Maximum Test Time in the Prefault and Fault settings box to a value different than ZERO.

2] Any parameter of the impedance can be manually “step ramped” from the control knob, up down arrows on the PC, or the mouse control wheel. The parameter is chosen by pressing or clicking on the control wheel icon and selecting “Include Channel in Ramping” from the numerical keypad.

3] The step increment (or decrement) is chosen by pressing the control wheel icon.

#### **3.6.7.1.14 ⑭ Impedance Test Screen**

This window shows the test vectors that are applied to the relay under test. With each ramp step you will see the test vector(s) change in amplitude and/or phase angle relationship.

#### **3.6.7.1.15 ⑮ Impedance Plane Screen**

This plane represents the ohm/loop domain for the phase-earth faults, and the ohm/phase domain for phase to phase and three-phase faults. By tapping on the screen, it is possible to graphically enter the impedance values.

### 3.6.8 Unknown Impedance Characteristic

This feature is used for testing an unknown impedance characteristic.  
For most cases the default settings below do not need to be changed.

**Prefault**  
Voltage 67 V Load Angle 0 (degree)  
Current 0 A Time 1 (s)

**Control**  
Constant Current 2 A

**CT/PT Ratios**  
Plot Primary Secondary

**Pulse**  
Max Trip Time (B) 5,000 (ms)  
Prefault Time(s) 200 (ms)

**Relay**  
MHO  
Three Phase  
Rca Guess 70 (degrees)  
Maximum Forward Reach 30 (ohms)  
Maximum Reverse Reach 0 (ohms)  
Trip Time Ratio for New Zone 115 (%)

**Search**  
Coarse Ramp Increment 0.5 (ohms)  
Second Ramp Increment 0.02 (ohms)  
Min Operation Time 100 (ms)  
Less Lines  
Use Polar Plot

Figure 189 Unknown Impedance Characteristic Setting Screen

#### 3.6.8.1 Prefault Dialog Box

The prefault values will be applied to the relay under test prior to ramping. If using Pulse Ramp the prefault values will be applied between each pulse increment. The *Prefault Dialog box* contains four edit fields:

- Voltage** – Enter a value of Voltage to be set.
- Current** – Enter a value of Current to be set.
- Load Angle** – Enter a value for a Load Angle to be set.
- Time** – Enter the desired time prior to applying the first test point.

#### 3.6.8.2 Control Dialog Box

This dialog box provides the user with a selection of different methods to perform the tests. Some manufacturers require Constant Voltage and ramp current, some require Constant Current and ramp voltage. In addition, the user may also select Constant Source Impedance.

- Constant Voltage** - Enter the value of volts to be held constant for all Fault Types tests under execution. Default value is 5.0.
- Constant Current** - Enter the value of amperes to be held constant for all Fault Types tests under execution. Default value is 1.0.
- Constant Source Z**- There are two forms of Source Impedance; Ohms and Angle ,or R and X. Enter the value of ohms and angle of source to be held constant for all Fault Types tests under execution or enter the R and X values where.

- R:** the Cartesian resistive equivalent of the impedance **[Z]** and its angle **Phi**
- X:** the Cartesian reactive equivalent of the impedance **[Z]** and its angle **Phi**

### 3.6.8.3 CT PT Ratios

This dialog box provides user selection for plotting the operating characteristic in either Primary or Secondary Ohms.

### 3.6.8.4 Relay Button

The user can input some basic knowledge, or best guess, of the relay to be tested.

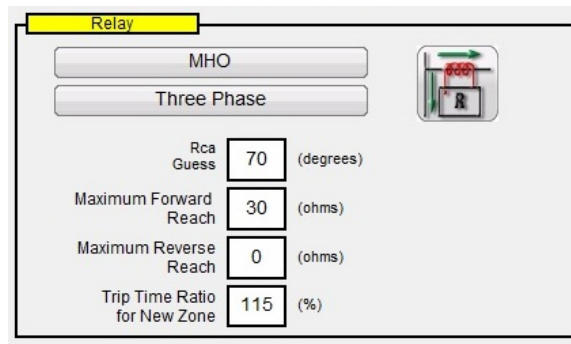

Figure 190 Relay Estimated Settings

There are three selections available for the relay type, **MHO**, **QUAD**, or **NONE**. The relay is either a **Three Phase** or **Single Phase** relay application. There are four best estimate settings. The **RCA** is a value set in degrees normally associated with the maximum torque angle, line angle, or positive impedance characteristic angle setting of the relay. Enter your best guess. **Maximum Forward Reach** is the estimated longest ohmic reach of the relay in the forward direction. **Maximum Reverse Reach** is the estimated longest ohmic reach of the relay in the reverse direction.

CT Earthing Position button 



This is the default position. The simulated secondary current from test system will be in phase with the primary current, which flows from the bus bar into the protected line.



If this button is selected, the simulated secondary current from test system will be 180 degrees shifted compared to the same primary current used as reference. The two pictures below show the output quantities from the test system for the same impedance of ten ohms at 85 degrees, single phase to earth fault, with the two possible CT earthing combinations.

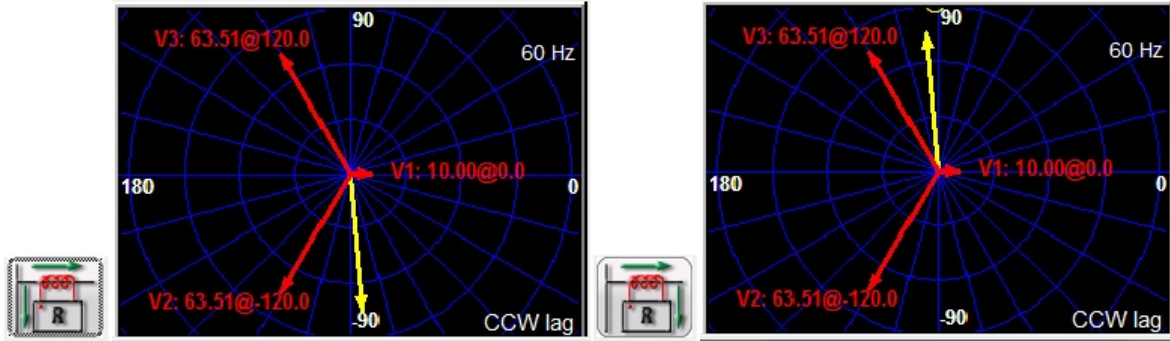

### 3.6.8.5 Ramp Options

This dialog box provides two different ways to determine the operating characteristic of impedance relays. Selection of the type of Ramp is dependent on the relay. To test Multi-Zone relays, use the Pulse Ramp Search. The software will automatically calculate the increment required in V, I, and phase angle. The Pulse Ramp Search also includes a **Prefault Time** setting in ms. This is the time that the prefault values will be applied between fault increments. The Stair Step ramp will only determine the characteristic for a single zone relay. There is one common setting for either the stair step or pulse ramps, **Max Trip Time**. Enter the estimated maximum trip time of the longest reaching zone.

### 3.6.8.6 Search Options

The Search Options will determine how fast and to what resolution the characteristic is found. The **Coarse Ramp Increment** will determine the size of the step taken on the initial ramp. The **Second Ramp Increment** will determine the pickup value with higher resolution. The **Min Operation Time** is the time that the fault value will be applied before making the next increment. There are three options regarding the number of test lines associated with determining the operating characteristic.



Figure 191 More, Less or One Test Line

**More Lines** will provide more test results with a better definition of the operating characteristic, but it may be too much data taking too long. Therefore, the **Less Lines** selection is made available, which may provide enough information to determine the operating characteristic. For fast determination select **One Line**, which may provide enough information to confirm your best estimate of the characteristic.

3.6.8.7 **Unknown Impedance Relay Test Screen** after entering the best-estimated settings of the relay to be tested, press the green check button, which will take the user to the Test Screen.

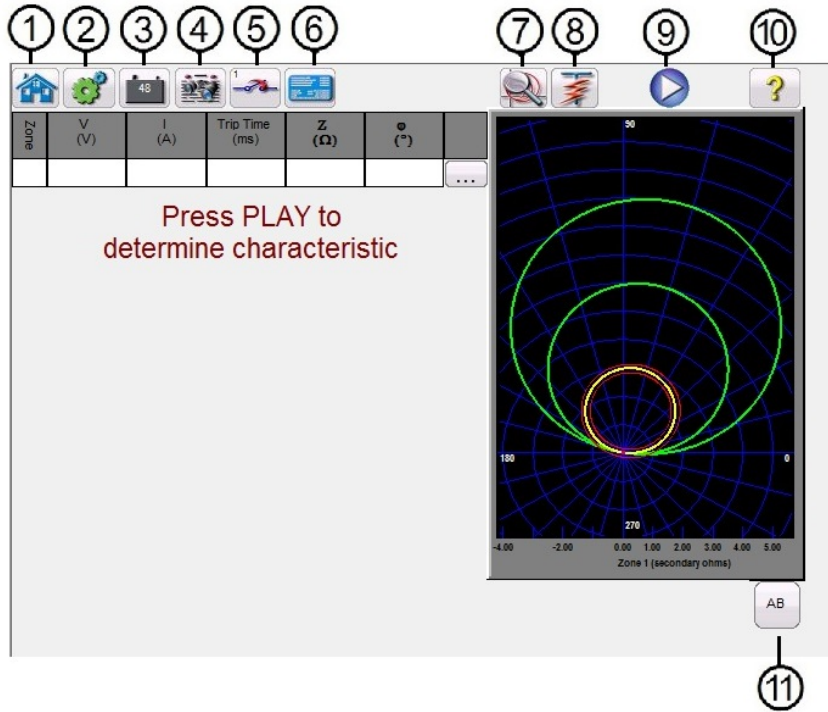



Figure 192 Unknown Impedance Relay Test Screen

3.6.8.7.1 ① Home button 

Pressing the home button will return you to the manual test screen.

3.6.8.7.2 ② Configuration button 

Press the button to go to the STVI Configuration Screen. See Section 2.2.1 Configuration for more information about the Configuration Screen.

3.6.8.7.3 ③ Battery Simulator button 

The Battery Simulator button – Turns the Battery Simulator ON and OFF by pressing the button, the color changes red for ON and black for OFF. The voltage to be applied is displayed in the button and can be changed by pressing the configuration button.

3.6.8.7.4 ④ Review Test Report button 

Press this button to review the test results.

3.6.8.7.5 ⑤ Binary Input Setting button 

Press this box to reveal the Binary Input Dialog box.

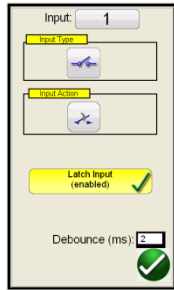

The default settings are Binary Input 1, dry contacts as indicated by the Input Type, and Input Action defaults to show the Closing of the Normally Open contacts. To change the Input Type from dry contacts to Voltage, press the Input Type icon, and it changes to voltage. To change to the opening of Normally Closed contacts press the Input Action icon and it changes to show closed contacts opening. For timing the operating time of the impedance element, the timer is defaulted to Latched Input enabled mode, which means the timer will stop on the first contact closure. Note the Debounce time is set to 2 ms.

#### 3.6.8.7.6 ⑥ Relay Settings Button

Press this button to access selection of the Relay's Settings Screen. Here the user can adjust parameters.

#### 3.6.8.7.7 ⑦ Zone Zoom button

Pressing this button will zoom in on the selected zone. Press it again and return to the normal test screen mode.

#### 3.6.8.7.8 ⑧ Run Predefined Test button

Pressing the Run Predefined Test button provides access to Predefined test plans, created by either Megger or users, in Pdb Tst file structure,

#### 3.6.8.7.9 ⑨ Run Test button

Pressing or clicking the blue Run Test button will run the selected Ramp to determine the unknown characteristic. If conducting the Pulse Ramp, it will apply the Prefault vector for the specified Time, then step to the Fault values and look for the relay under test to operate.

#### 3.6.8.7.10 ⑩ Help button

The Help button is sensitive to the test. It will take the user to this section of the manual. It is also used to reset the unit.

### 3.6.8.7.11 ⑩ Fault Selection button



This button provides user selection of the desired fault to be tested. The choices are Phase to Ground, Phase to Phase, and Three Phase.

### 3.6.9 Megger Characteristic Editor

The Megger Characteristic Editor, MCE, is accessed from the Impedance Relay Library, see the following figure.

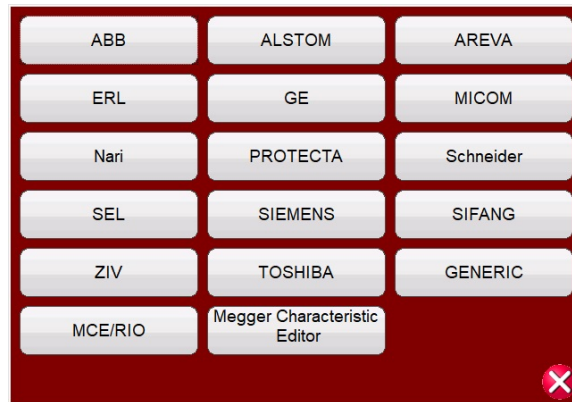

Figure 193 Impedance Relay Library List

The MCE is a tool for creating impedance relay operating characteristics using combinations of Lines, Arcs, and/or MHO circles. Any impedance characteristic can be created using this tool, saved, and imported into the Click on Fault Impedance relay test screen.

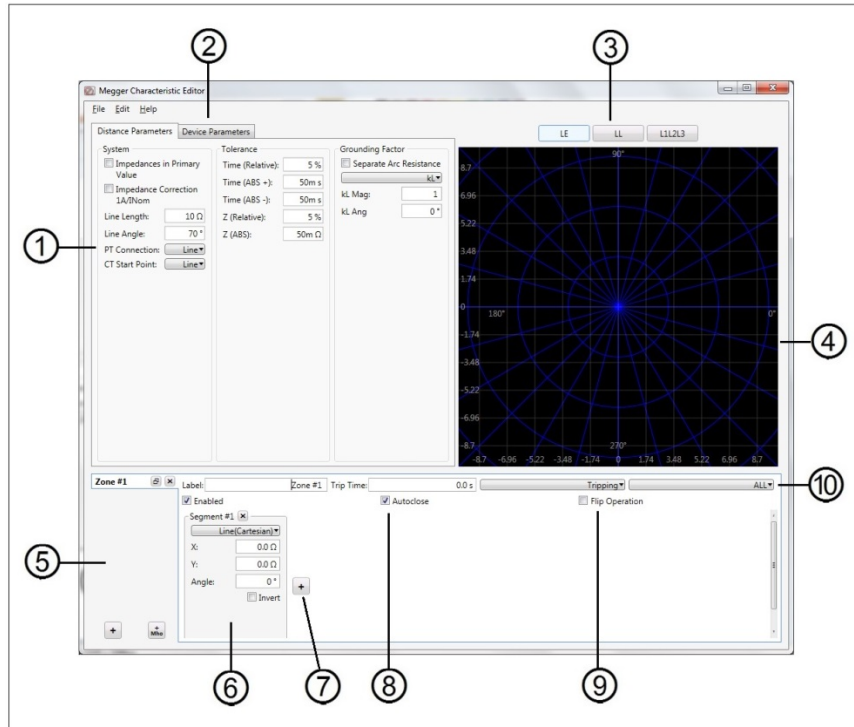

Figure 194 Megger Characteristic Editor Distance Parameters Screen

### 3.6.9.1 ① Distance Parameters Settings

The Distance Parameters settings are the values used in defining the System, Tolerance, and Grounding Factors used for testing the relay. Some of these values are imported into the Click on Fault relay settings window.

#### 3.6.9.1.1 System Settings

**Impedance in Primary Values:** Check the box provided if the values provided are in primary values. This provides for plotting the operating characteristic in Primary Ohms, when imported into RTMS Click on Fault test screen.

**Line Length:** Enter the line length in Ohms.

**Line Angle:** Is a value set in degrees normally associated with the maximum torque angle, line angle, or positive impedance characteristic angle setting of the relay.

**PT Connection:** The pull-down button is associated with the PT earthing/grounding towards the Line or towards the Bus. It defaults towards the Line. This defines how phase angles are calculated.

**CT Start Point:** The pull-down button is associated with the CT earthing/grounding towards the Line or towards the Bus. It defaults towards the Line. This defines how phase angles are calculated.

#### 3.6.9.1.2 Tolerance Settings

**Time Relative:** Enter the relative accuracy of the timing elements in the relay as a percentage. The default is 5%.

**Time (Abs +):** Enter timing accuracy in positive absolute error in ms. The default is + 50 ms.

**Time (Abs -):** Enter timing accuracy in negative absolute error in ms. The default is - 50 ms.

**Z (Relative):** Enter the relative accuracy of the impedance measuring element (in Ohms) in the relay as a percentage.

**Z (ABS):** Enter the impedance measuring element in absolute value in Ohms.

### 3.6.9.1.3 Grounding Factors

For single phase to ground faults a pull-down selection list is available. For Mho characteristics **KL** and **Z0/Z1** are available. The residual compensation factor, KL, is a complex number that is used to express the earth-return impedance, ZN, in terms of the positive-sequence impedance reach setting, Z1. This factor is calculated as:

$$KL = ZN/Z1 = (Z0 - Z1)/(3Z1)$$

Where: Z0 is the zero-sequence impedance polar reach of the zone. **Z0/Z1** Ratio = the complex ratio of **Z0/Z1**, also referred to as **K0=Z0/Z1**

For QUAD (quadrilateral) there are: **KL**, and **RE/RL & XE/XL**

**RE/RL & XE/XL** is a pair of scalar factors. These factors affect the resistive reach and reactive reach of some polygon characteristics.

$$RE/RL = (R0/R1 - 1)/3$$

$$XE/XL = (X0/X1 - 1)/3$$

Where:

R1 = real part of Z1

X1 = imaginary part of Z1

R0 = real part of Z0

X0 = imaginary part of Z0

Depending on which compensation factor is selected, different value boxes will appear for magnitudes and angles to be entered.

### 3.6.9.2 ② Device Parameters

The selection of this tab will present the following screen.

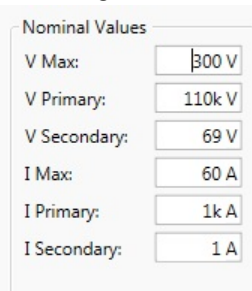

The screenshot shows a window titled "Nominal Values" with six input fields:

Parameter	Value
V Max:	300 V
V Primary:	110k V
V Secondary:	69 V
I Max:	60 A
I Primary:	1k A
I Secondary:	1 A

Figure 195 Device Parameters Settings window.

**V Max:** Use this to limit the amount of voltage that can be applied to the relay under test. The value defaults to 300 V, which is the maximum available voltage from a SMRT voltage amplifier.

**V Primary:** Enter the PT primary voltage level of the line being protected. This value will be imported into the Click on Fault CT PT settings windows and provides for plotting the operating characteristic in either Primary or Secondary Ohms.

**V Secondary:** Enter the PT secondary voltage level being applied to the relay under test. This value will be imported into the Click on Fault CT PT settings windows and provides for plotting the operating characteristic in either Primary or Secondary Ohms.

**I Max:** Use this to limit the amount of current that can be applied to the relay under test. The value defaults to 60 A, which is the maximum available current from a SMRT1/36/46/410 current amplifier.

**I Primary:** Enter the CT primary current level of the line being protected. This value will be imported into the Click on Fault CT PT settings windows and provides for plotting the operating characteristic in either Primary or Secondary Ohms.

**I Secondary:** Enter the CT secondary current level being applied to the relay under test. This value will be imported into the Click on Fault CT PT settings windows and provides for plotting the operating characteristic in either Primary or Secondary Ohms.



### 3.6.9.3 ③ Fault Selection Boxes

The user can define **LL**- Phase to Phase fault, **L1L2L3**- 3 Phase Fault, or **LN**- Phase to Ground fault.

### 3.6.9.4 ④ Impedance Plane Screen

By double-tapping on the screen it is possible to expand the screen. The screen can be expanded two times to get a better look at small impedance elements or segments. Double-tapping after two expansions will reduce the screen back to original size.

### 3.6.9.5 ⑤ Zone Selection Box

The user can add and define up to 20 Zones by pressing the  button at the bottom of the box, or if the characteristic is an MHO circle the  + MHO button. One zone will be added each time it is pressed. The user can define **LL**- Phase to Phase fault, **L1L2L3**- 3 Phase Fault, or **LN**- Phase to Ground fault for each zone. To disable the Zone, uncheck the Enable button. Zones can be created and either Enabled (default position) or Disabled (to be Enabled later).

**Application Note:** To save time, after defining the impedance characteristic use the Duplicate Zone  button. Select one of the other fault types, and all the values entered for the previous fault type will be entered for the other fault type. Note this should be limited to only same zone fault types.

### 3.6.9.6 ⑥ Segment #n

Impedance characteristics can be created using lines, arcs, and/or MHO circle combinations defined by multiple segments. Combinations of MHO circles are easy. Click on the +MHO button, input the Zone **Reach** in Ohms, input the **Angle** (normally the line angle), and if there is no **Offset** input the offset to 0 degrees. For all other impedance characteristics, click the pull-down **Line (Cartesian)** button to view available impedance segment elements, see the following figure.

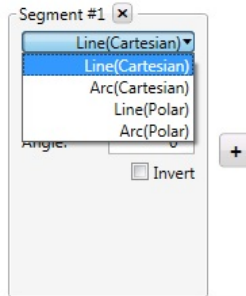

Figure 196 Impedance Segment Elements

Element selection line segments can be defined as follows.

**Line (Cartesian):** Used with relays that are defined using R and X values only, or combined segments using R and Z, see Line (Polar). Enter X and Y in Ohms with an Angle.

**Line (Polar):** Used with relays that are defined using Z values, or combined segments using Z and R values. Enter Z in Ohms, an angle Phi (where Z line crosses at a right angle), and an Angle (the “tilt” angle) of the line crossing Phi at the defined Ohmic Z value.

**Arc (Cartesian):** If the Arc is to be centered around the origin, leave X and Y at 0  $\Omega$ , otherwise enter the X and/or Y Ohmic values to offset the MHO circle in the impedance plane. For the Radius, enter the Ohmic operating characteristic in Ohms. Start and Stop Angles are used to define arcs of less than 0 to 360°. This will become more apparent when you add lines that intersect the arc. The **CCW** and **CW** may flip the arc 180° depending on the defined intersecting line segment.

**Arc (Polar):** Enter Z in Ohms for the center of the locus at the angle Phi. For the Radius, enter the Ohmic operating characteristic in Ohms. Start and Stop Angles are used to define arcs of less than 0 to 360 degrees. This will become more apparent when you add lines that intersect the arc. The **CCW** and **CW** may flip the arc 180° depending on the defined intersecting line segment.

**Invert:** Check this box the invert the characteristic 180°.

### 3.6.9.7 ⑦ Add Segment Button

To add additional impedance segments, press this button. There is no limit as to how many segments can be added. Additional segment description boxes will be displayed to the right and then below Segment #1.

### 3.6.9.8 ⑧ Autoclose button

When the Auto close button is checked, as each segment is added, the characteristic will start to “build” by the combining of the lines and/or arcs until the final segment is added “closing” the characteristic shape. In the case of a Blinder or Ohm characteristic, define the line and angle, and do not check the Auto close button. This will extend the line to infinity.

### 3.6.9.9 ⑨ Flip Operation button

Clicking the Flip Operation button will “flip” the impedance characteristic 180°.

### 3.6.9.10 ⑩ Defining Impedance Operations Row

**Label:** Click in the window to provide a label for the created impedance characteristic. It is recommended to limit the number of characters to ten.

**Trip Time:** Click in the window to enter the trip time in seconds. This information will be imported into the Click on Fault test screen and used in the test report. For operating times in ms, enter the time in tenths, i.e., for fifty ms enter 0.05 s.

**Tripping** pulldown button: Click on this button to reveal the following list.

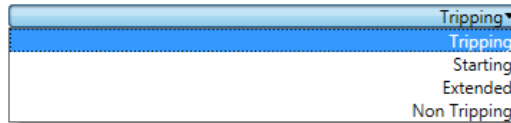

Figure 197 Defining Impedance Characteristic

Choose from this list to define what the impedance characteristic is, see the following descriptions.

**Tripping:** In most cases the impedance characteristic will be tripping.

**Starting:** Some relays have starting characteristics, where the relay will not start to make impedance measurements until the impedance has crossed the boundary of the starting characteristic, such as in power swing detection.

**Extended:** This is typically used when defining accelerated tripping or dynamic over-reach characteristics.

**Non Tripping:** Used to define a non-tripping impedance characteristic, i.e., blocking.

**ALL** pulldown button: Click on this button to reveal the following list.

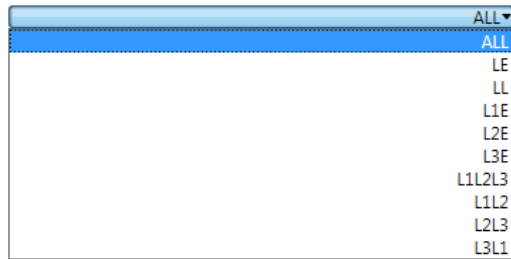

Figure 198 Defining Fault Type for Impedance Characteristic

Some relays may be designed for single phase, some for phase to phase, and some for three phase protection. Select which fault type the relay impedance characteristic is designed to protect.

### 3.6.9.11 Creating Impedance Characteristics

The following example combines MHO circles, with ARCS and lines to create a three zone protection relay with load encroachment.

For this example, the following System Setting values were used.

Line Length: fifty  $\Omega$ .  
 Line Angle:  $85^\circ$   
 Time Tolerance: 5% with +/- 5 ms ABS  
 Z Relative: 5%  
 Z Absolute: ten m $\Omega$   
 Ground Compensation Factors: 720 m $\Omega$ , -  $3.69^\circ$ .

The first two zones are MHO circles.

For Zone 1, Segment #1, select + Mho Circle. Application Note: Clicking on the + Mho button will add the Mho circle as Zone #2. Click on Zone #1  box and delete the default Zone #1, thus making your added Mho circle Zone #1. The reach was set to 10  $\Omega$ , zero  $\Omega$  Offset, at a line angle of  $85^\circ$ . The Label was changed to read Zone #1, the trip time was set to 50 ms, and defined as Tripping, ALL. The Zone is Enabled and Auto close is checked.

For Zone 2, Segment #1, select + Mho Circle. The reach was set to 20  $\Omega$ , zero  $\Omega$  Offset, at a line angle of  $85^\circ$ . The Label was changed to read Zone #2, the trip time was set to one hundred ms, and defined as Tripping, ALL. The Zone is Enabled and Auto close is checked.

Zone 3 will take a combination of two Arcs and a line to form a Mho characteristic with the load encroachment notch cut out.

1. First step, we will need to describe the line associated with the load encroachment. Since this characteristic has a line through the origin, we will add a Cartesian Line with X and Y left at 0  $\Omega$  and insert the angle. In this example, an angle of  $30^\circ$  is used. Note that the line is not drawn yet. Click on the Add Segment button . You will note that the line extends  $30^\circ$  in the reverse direction. Click on the Invert button to flip the line  $180^\circ$  in the forward direction.

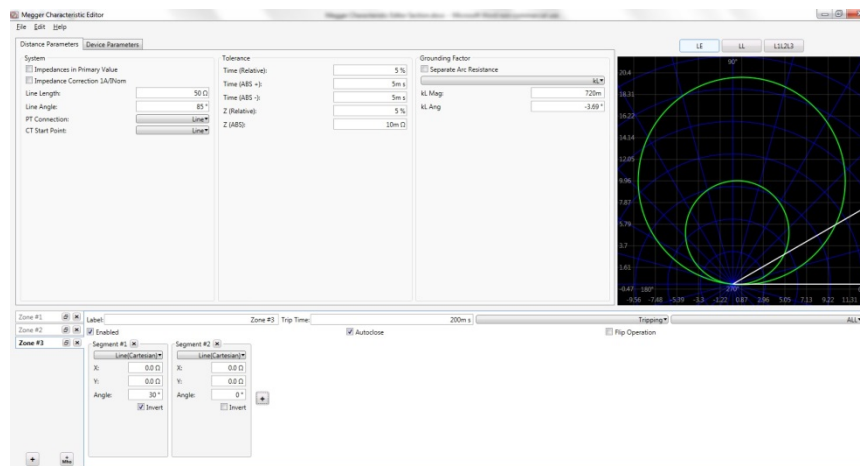



Figure 199 Step 1 Load Encroachment Line Characteristic

2. The second step is to define the Zone 3 Mho Characteristic using Arc Polar. Click on the Add Segment button , and select Arc (Polar). The Arc Polar defaults to Z = 0.0  $\Omega$ , Phi =  $0^\circ$ , and

Radius = 1  $\Omega$ . Therefore, what you will see is a half-moon characteristic centered on the origin, with a radius of one  $\Omega$  (a combination of the 30° line and the 1  $\Omega$  circle at the origin).

- The next step is to set the forward reach of the Zone 3 characteristic. The forward reach will be a combination of Z, Phi, and Radius. We want the forward reach to be equal to 30  $\Omega$  at the line angle of 85°. Set Z = 15 Ohms, Phi = 85°, and Radius = 15  $\Omega$ . Z represents the offset of the loci 15  $\Omega$  in the forward direction, combined with the 15  $\Omega$  of the circle radius, results in a Zone 3 Mho of 30  $\Omega$  at 85°. What you see now is a partial Mho circle with a flat side caused by the line added in step 1.

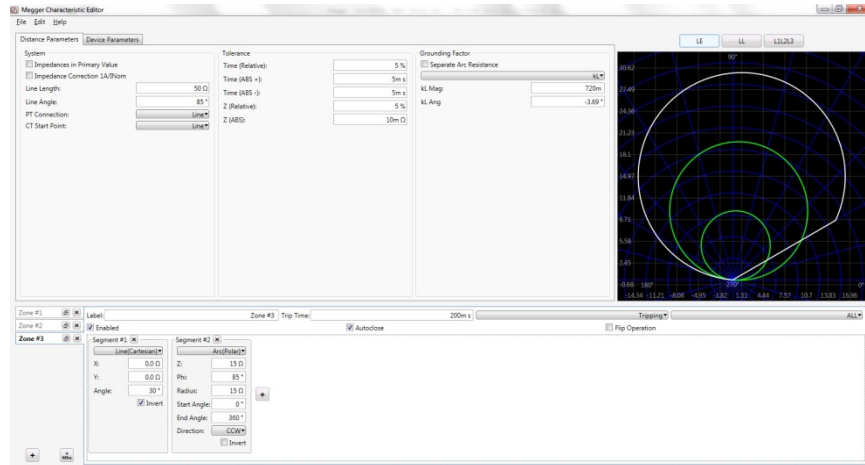



Figure 200 Step 2 Load Encroachment Characteristic

- The final step is to add another Arc Polar that represents the forward reach of Zone 3 up to the notch cutout for the load encroachment. Click on the Add Segment button . Select Arc (Polar). Look closely and you will see a small arc near the origin. This is a combination of the circle around the origin of one  $\Omega$  (recall the default settings) and the line from step 1. We now want to move the arc in the forward direction to represent Zone 3 operating characteristic with load encroachment set at 14  $\Omega$ . Enter Radius = 14  $\Omega$ . The Label was changed to read Zone #3, the trip time was set to four hundred ms, and defined as Tripping, ALL. You should now see the completed Zone 3 with the load encroachment notch, see the following example figure.

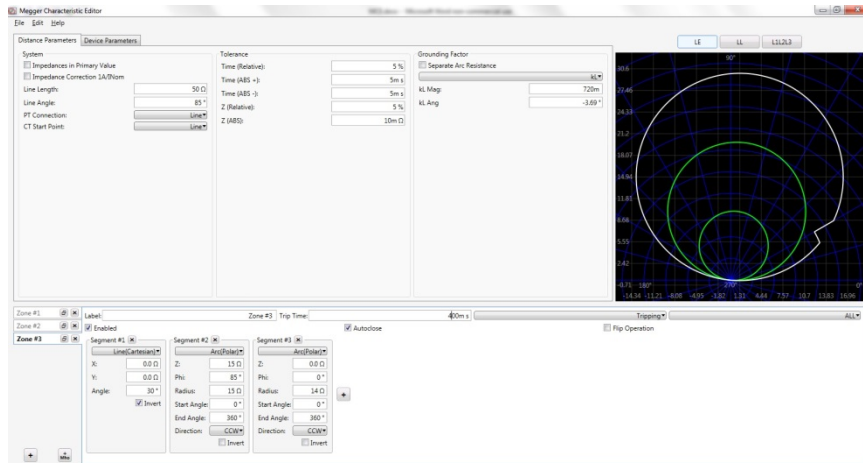



Figure 201 Example 3 Zone Impedance Characteristic with Load Encroachment

- To save the created characteristic, click on File, Save As, give it a name. The impedance characteristic is now saved for use in the Click on Fault test screen.

### 3.7 Testing Transducers with RTMS

In conjunction with the Transducer Hardware Option in the SMRT units, the Transducer Test provides a quick approach to testing all types of single phase and three phase electrical transducers. The transducer hardware “T” option can either be ordered with the new test set or later as a factory hardware upgrade.

Press the Select New Test button  to get access to the Transducer Test. Then press the Transducer icon button . The Transducer Test Screen will appear.

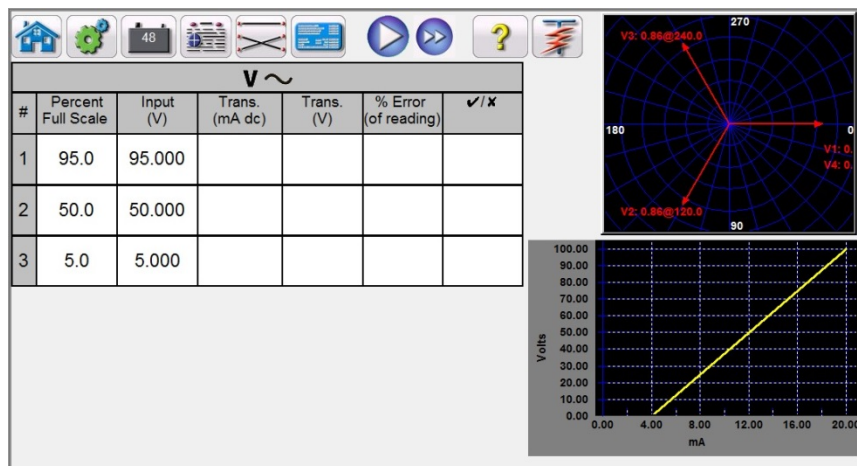

Figure 202 Transducer Test Screen

The test screen defaults to three test points set at 5, 50, and 95% of Full Scale. To change the number of test points, the percentage for each test point, or select the type of transducer to test, press the settings  button. The Transducer Setup Screen will appear.

Figure 203 Transducer Setup Screen

This screen is used for selection of single phase or three-phase transducers such as; AC and DC Voltage, AC and DC Current, Frequency, Power (W), Reactive Power (VAR's), Apparent Power (VA) and Power Factor.

### 3.7.1 Transducer Setup Screen

The following are descriptions for each section within the Transducer Setup Screen.

#### 3.7.1.1 Nameplate Section

In the description windows the operator enters descriptive information relative to the transducer to be tested. This information will be saved with the test results. The following describes the window entries.

**Description:** Input a short description of the transducer to be tested.

**Manufacture:** Input the name of the transducer manufacturer.

**Model:** Enter transducer model number .

**Serial Number:** Enter the serial number of the transducer.

#### 3.7.1.2 Type Selection Section

The user may select from a variety of transducers, in the **Type** Section. Here the operator may select, by pressing or clicking the selection window, the type of transducer that he/she needs to test. In addition the user selects the output of the transducer, either a voltage or a current output by pressing the provided button (toggles between Voltage and Current).

Watt, VAR and VA transducers come in 1, 1 ½, 2, 2 ½ and 3 element configurations. Selecting the number of elements will automatically select the appropriate number of output voltages

and currents needed to test the selected transducer. For example, selection of a single element Watt transducer, V1 and I1 sources will automatically be selected for you. In the case of a three-phase 3 element transducer V1,V2, V3, I1, I2 and I3 will be preselected for your use.

Selections available are:

<u>Single Phase</u>	<u>Multi-Phase</u>
AC Volts	Watts/VAR/VA - 1 1/2 Element
AC Current	Watts/VAR/VA - 2 Element
DC Volts	Watts/VAR/VA - 2 1/2 Element
DC Current	Watts/VAR/VA/Power Factor - 3 Element
Frequency	
Watts/VAR/VA/Power Factor - 1 Element	

### 3.7.1.3 Test Settings Section

Some of the system default settings come from the **Configuration Screen**. The user can set the number of test points, the Settling Time, and when testing Watt, VAR, or VA whether to use Constant Current (and vary the voltage) or Constant Voltage (and vary the current).

**# Of Test Points:** The software automatically defaults to 3 test points, 5, 50, and 95% of Full Scale. The user can select any number of points from 1 to 10. In the Test Screen the user can change the % of Full Scale for each test point from the preselected values.

**Settling Time:** This is the time delay, in s or ms, the test system will wait before making it's first accuracy calculation and freeze the readings. If the transducer is self energized, the operator needs to allow enough time for the transducer to stabilize before making an accuracy calculation. The default time value is set in seconds. To set a setting time in milliseconds press or click on the blue colored s, and it will change to ms for milliseconds. For example, assume the transducer settling time is 1,000 ms, or 1 s. The operator needs to enter a settling time of 1 s. When the test values are applied, the system will wait 1,000 ms (1 s) before calculating the % error deviation. Then, the % error with pass/fail information is displayed and the test values are frozen. At this point the operator may choose to Stop the test and Save results.

**Warmup Time:** Many transducers require a warmup time before accuracy tests are performed. Enter the warmup time in s.

**Constant Current:** If the operator chooses Watt, VAR or VA in the **Type** window, a Full Scale voltage (based upon the current value entered) will automatically be calculated and entered for you. The value will be calculated based on the Watts, VAR or VA value entered in the **Input Range** Section. The current value will automatically default to 5 A. The user is free to change the value to any desired fixed output current in the window provided.

**Constant Voltage:** Pressing the Constant Current button changes the output configuration to Constant Voltage. A Full Scale current (based upon the voltage value entered) will automatically be calculated and entered for you. To change the value, press the display window and enter the desired voltage value.

**Aux. Voltage:** If the transducer uses an Auxiliary Voltage source for power, enter the voltage value here.

**Power Factor:** Pressing the Power Factor button in the Type window will provide default test values of 69 Volts and 1 A in the Test Settings window. The Power factor test will be performed using these values unless the user changes them. To change the values, press the display windows and enter the desired voltage and current values.

#### 3.7.1.4 Input Range Section

The operator inputs the full scale input range of the transducer to be tested. For example an AC Current Transducer may have a range of 0 to 1, or 0 to 5 A. Enter the appropriate values for the transducer to be tested.

#### 3.7.1.5 Output Range Section

Depending upon the type of output selected in the Type section, the transducer will have either a dc voltage or DC mA output. The default settings are 0 to 10 VDC, and 4 to 20 mA DC. It should be noted that Minimum Value could be a negative dc value. For example, - 1 mA, or - 10 VDC. It could also be a positive dc value, other than 0. The firmware will calculate the scaling factor based on the minimum and maximum values, and use this scaling factor to calculate the actual output from the transducer (in terms of V, I, W etc).

Voltage or Current : The operator selects one by pressing or clicking the button associated with either the Voltage or Current in the Type window. If the Min. and/or Max. are different from the defaulted values, the operator touches the appropriate window and a numeric keypad will appear to enter the appropriate value(s). In the following example, the transducer is a Watt transducer. When **Watt 3 Element** was selected in the **Select Transducer Type** window, **W** (Watts) appears in the Transducer Input range window.

In this example, a value of 1500.0 was entered as the maximum input. The Output Range was set 0 to 1.00 mA. Therefore, the scaling factor will be,

$$0 \text{ mA} = 0.0 \text{ W, and } 1.000 \text{ mA} = 1500.0 \text{ W or,}$$

$$1\text{mA}/1500.0 \text{ W} = 0.00066666 \text{ mA/W}$$

Therefore, if the transducer had a measured output of .250 mA, then the equivalent Watts output would be,

$$0.250 \text{ mA}/0.00066666 \text{ mA/W} = 375.0 \text{ W}$$

**Tolerance:** The accuracy value for the transducer is entered here. The default value is in Percent of Reading. To change to Percent of Range (or Full Scale) touch the Percent of Reading button. To enter another value, the user touches the value window and a keypad allows another value to be entered.

With all the values entered in the Transducer Setup Screen, to return to the Transducer Test Screen press the green check  button at the bottom of the screen.

### 3.7.2 Transducer Test Screen

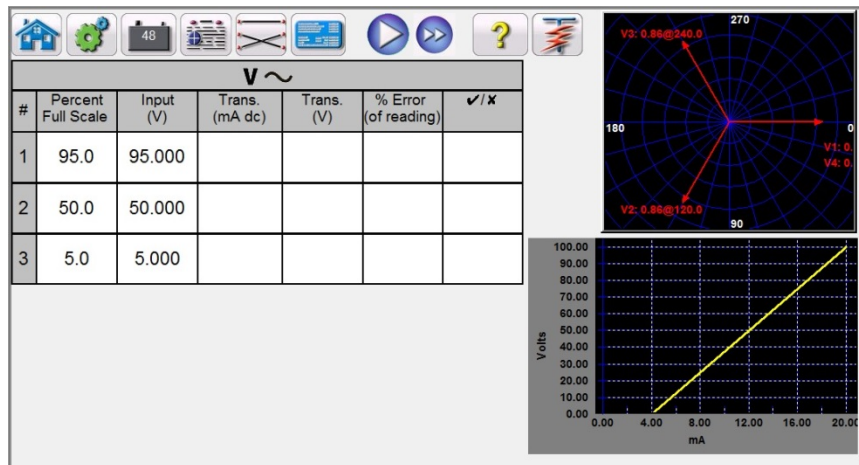

Figure 204 Transducer Test Screen

The **Transducer Test Screen** has three parts. The **Output** section where the test values to be applied to the transducer appear, the **Transducer Output** section where the DC Reading, % Error and Pass/Fail appear, and the **Vector** Section.

#### 3.7.2.1 Output Section

When selecting the type of transducer to test in the Setting Screen, the appropriate outputs will automatically be selected for the user. For example, if an AC Voltage transducer had been selected, the V1 output selection button will have changed to green, and the defaulted voltage would appear. In the above example a single phase AC Voltage Transducer was selected, with a Full Scale Input of 100 V. The first default test point is 95% of Range.

Therefore, a test value of 95 V appears for V1 output. The default frequency will also be preset. If a DC transducer had been selected, the Freq. Window for the selected voltage or current would read DC.

### 3.7.2.2 Transducer Output Section

In the following example, a 3 Element 1,500 W transducer was selected in the **Setting Screen**. It automatically defaults to 3 test points of 0, 50, and 95% of Full Scale, note the calculated Watts to be applied. Pressing the blue Run Test button will apply the test values as displayed in the Input column. This value will be used later to calculate % error and PASS/FAIL.

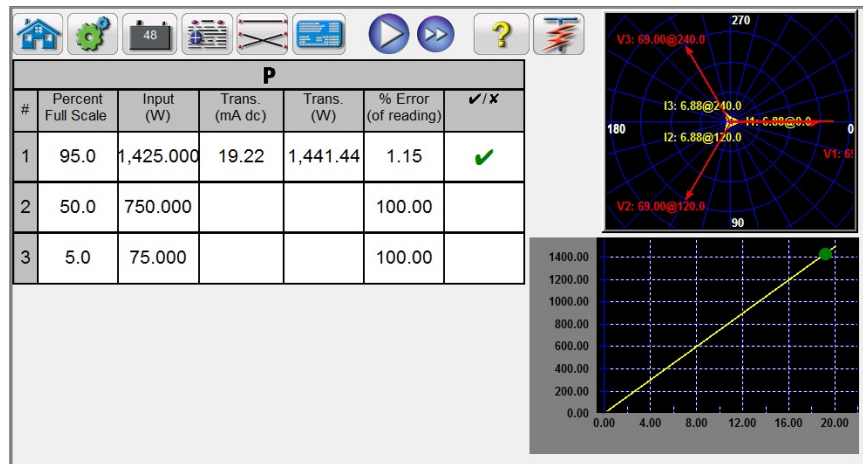

Figure 205 Example Power Transducer

The transducer output section displays the equivalent output in the select type value (Reading V, A, W, VA, etc.). Depending on the desired measurement set in the setting screen the % Error will be either of range, or of reading. From this the Pass/Fail will be determined and displayed.



The accuracy is calculated as follows,

$$\left( \frac{\text{Transducer Output} - \text{Measured Output}}{\text{Measured Output}} \right) \times 100$$

If the value displayed in the Accuracy window meets the Accuracy specification set in the Transducer Setup Screen, an affirmative PASS will be displayed. If it exceeds the setting specifications, a negative FAILED will appear.

### 3.7.3 Testing Transducers

1. In the Transducer Setup Screen, enter the transducers specific data, such as manufacturer, model number and serial number.

2. Select the transducer type to be tested.
3. Enter the transducer's output in DC V or mA. Include the min. and max. values for the type of output, which correlates to the voltage or current. Input the transducer's accuracy value.
4. Enter the transducer's settling, or response time in ms (allow extra time for self powered transducers).
5. Press the green check  button at the top of the screen.
6. Based on the type of transducer selected the appropriate outputs will have already been pre-selected for you. If you desire to test at some other value(s) than those preset, press the window for the value(s) you wish to change, and a numeric keypad will appear. Using the keypad, enter the desired value(s).
7. Connect the selected outputs to the appropriate transducer's input terminals.
8. If the transducer requires an external power source (for the AUX. Power input), connect to your external power source.
9. Press the **Run Test**  button to execute a single test or press the **Run ALL**  to run all the tests. The outputs will turn on.
10. Note the test result in the Transducer Output section of the window.

#### 3.7.4 Saving Results

1. With the test completed, the results and test file need to be saved to the internal solid-state disk. To do this, press the **File** button. This will take the user to the **Save As** window.
2. Enter a file name, and press the Save As button. The test and data are now saved. See **File Manager** section for additional information.

#### 3.7.5 Watt/VAR/VA/Power Factor Applications

As previously described, Watt and VAR transducers come in 1, 1 1/2, 2, 2 1/2 and 3 Element configurations. In the Transducer Setup Screen, the operator is required to select what type of transducer is to be tested. Once selected, RTMS will make certain assumptions and calculations based on the number of elements selected. The following are detailed descriptions of the different elements and the calculations required to calculate Watts and/or VARs.

##### 3.7.5.1 Watt/VAR 1 Element

The single element Watt transducer requires 1 voltage and 1 current to test. The test set will automatically select the first voltage and current channels available, **V1** and **I1**. The test will initially start at the default value voltage unless changed by the user (select constant voltage and enter the desired output voltage). For example, 120.0 V L-N. When the user inputs the Watts value in the **Transducer Setup Screen**, the firmware can calculate the required test current for full scale value. Since the default angle will be 0° (zero degrees), the calculation is simple. The formula required to calculate Watts is,

$$V1 * I1 * \text{COS } 0^\circ = W$$

Example: The default voltage is 120.00 VAC, and the user inputs 500 W as Max. Value. The current required for **full scale** output from the transducer is,

$$120 * I_1 * \cos 0^\circ = 500 \text{ W} \quad \text{simplifying, } I_1 = 500/120, \text{ or } I_1 = 4.1667 \text{ A}$$

Note that the first default test point is set to 90% of Full Scale, which will result in a test current of 3.750 A. Therefore, if the user wants to test at the full scale input of 500 W, in the Test Screen touch the percent full scale window and enter 100. The test should automatically show a test current value of 4.167 A at an angle of 0°. Note, the voltage is also in-phase with the current at 0°. Also, note that the current is rounded up to 7 in the last digit displayed.

When the test is Started, the measured voltage and current outputs are displayed and the calculated Watts is based on the measured voltage and current outputs. This is the value that gets displayed in the 2<sup>nd</sup> column of the **Transducer Output** section. Another value of Watts gets calculated using the measured DC V or DC mA output as displayed in the 3<sup>rd</sup> column. The percent error will be displayed in the 4<sup>th</sup> column. Let us assume that in our example transducer, the output is in DC mA. For this example, let us say that 1 mA of DC current is equal to the full scale output of 500 W. Therefore, the theoretical output W from the transducer would be 500 W, if the output current is 1 mA. For this example, let's say that the measured output voltage is 120.01 V, at 0°, and the measured output current is 4.166 A, at 0.0°. The measured output W would be,

$$120.01 * 4.166 * \cos 0.0 = 499.96 \text{ W}$$

For this example, let's assume the measured output current from the transducer is 0.996 mA dc. Based on a Max. value of 1 mA equals 500 W, the displayed **Watts** in the **Transducer Output** section of the **Transducer Test Screen** should read  $500 * 0.996 = 498.0 \text{ W}$

The **Accuracy** displayed in the **Transducer Output** section would be equal to the following,  $(498.0 - 499.96/499.96) * 100 = \% \text{ accuracy}$  or - 0.392%

If this were a 0.5% transducer, then the firmware would compare the accuracy values between the Setting Screen and the Test Screen and would display **PASS** in the **Transducer Output** section of the test screen. If this were a 0.2%, then it would display **FAILED**.

**Note: All of the calculations are very similar when testing VAR 1 Element transducers.** The primary difference is replacing the COS function with the SIN function.

**Note: Calculations for VA transducers are the same except there are no COS or SIN functions.** Therefore, the apparent power (VA) calculation is simplified as  $V * I$ . For example, for the calculation above the apparent power is,

$$120.01 * 4.166 = 499.96 \text{ VA}$$

### 3.7.5.2 Power Factor 1 Element

The single element power factor transducer requires 1 voltage and 1 current to test. The test set will automatically select the first voltage and current channels available, **V1** and **I1**. The test will initially start at the default values for voltage and current. For example, 120 V L-N, and 5 A. The Power factor transducer has a range of operation that correlates to the Leading or Lagging phase angle relationship between the voltage and current inputs. Therefore, when the user selects Power Factor 1 Element, the **MIN** and **MAX** nomenclature will change to read **LEAD** and **LAG** power factor values. The user is required to input the **LEAD (MIN)** and **LAG (MAX)** power factor values into the provided spaces (normally the same values, i. e. 0.5). The power factor is the trigonometric decimal equivalent value of the COS of the angle between the V1 voltage and I1 current. For example, when the user inputs the **LEAD** and **LAG** Power Factor values in the **Transducer Setup Screen**, the firmware can calculate the required test angles for full scale values. Thus for a **LAG** Power Factor value of 0.5, the current would need to lag the voltage by 60°. The Lead and Lag phase angles require that the vector display be changed to show angles as  $\pm 180^\circ$ . If the default angle representation is 0 to 360 LAG, then the angle between the voltage and current will be considered lagging (current lags voltage). In this situation, the typical test angles may vary between 0 to 90° lag and 359.9 to 270° lag (90° leading). This could cause some confusion to the user. By forcing the display to  $\pm 180^\circ$  simplifies the testing considerably. The test will start at unity power factor, or  $\pm 0^\circ$ . Since the default angle will be 0° (zero degrees), the calculation is simple. The formula required to calculate Power Factor is,

$$\text{COS } \angle 0^\circ = 1.000 \text{ Power Factor } (V1 \angle 0^\circ, I1 \angle 0^\circ)$$

Example: The default voltage is 120.00 V and current is 5 A AC, and the user inputs a Power Factor of  $\pm 0.3$  as **LEAD** and **LAG** Values. The angles required for full scale output from the transducer is,

$$0.3 \text{ Power Factor} = \text{COS } 72.5^\circ \quad \text{or, } + 72.5^\circ \text{ LEAD and } -72.5^\circ \text{ LAG}$$

When the test is Started, the measured voltage and current outputs are displayed and the calculated Power Factor is based on the measured phase angle between the voltage and current outputs. This is the value that gets displayed in the **Transducer Test Screen** under the **Reading (V or mA) column**.

Another value of Power Factor gets calculated using the measured DC V or DC mA output as displayed in the **Transducer Output** section. Let us assume that in our next example transducer, the output is in DC mA. For this example, let us say that  $\pm 1$  mA of DC current is equal to the full scale Power Factor of  $\pm 0.5$ . Therefore, the theoretical range of output from the transducer would be - 0.5 Power Factor, if the output current is -1 mA, to + 0.5 Power Factor, if the output current is +1 mA. For this example, let's say that the measured output voltage is 120.0 V, at 0°, and the measured output current is 5.000 A, at a lagging angle of - 30°. The calculated Power Factor would be,

$$\text{COS } - 30^\circ = - 0.866$$

For this example, let's assume the measured output current from the transducer is - 0.489 mA DC. Based on a Lead/Lag value of  $\pm 1$  mA equals  $\pm 0.5$  PF, the scaling would be equal to

$$0.5 \text{ PF} = \text{COS } 60^\circ$$

$$1 \text{ mA}/60^\circ \text{ or } 0.016666 \text{ mA per degree.}$$

Therefore, the displayed **PF** in the **Transducer Output** section of the **Transducer Test Screen** should read

$$- 0.489 \text{ mA}/0.016666 \text{ mA/Degree} = - 29.34^\circ$$

$$\text{COS } - 29.34^\circ = - \mathbf{0.871 \text{ PF}}$$

Power factor transducer accuracies are stated in units of Power Factor, not in % error. Therefore, the **Accuracy** window for Power Factor transducers needs to change from % error to  $\pm \mathbf{0.000 \text{ PF}}$ . The **Accuracy** displayed in the **Transducer Output** section would be equal to the following,

$$0.871 - 0.866 = + \mathbf{0.005 \text{ PF}}$$

If this were a 0.01 PF transducer, then the firmware would compare the accuracy values between the Setting Screen and the Test Screen and would display **PASS** in the **Transducer Output** section of the test screen.

### 3.7.5.3 Watt/VAR1 1/2 Element

This transducer is normally used in single-phase, three wire applications, which requires 2 voltages and 2 currents to test. The test set will automatically select the first two voltage and current channels available, **V1**, **V2**, **I1** and **I2**. The voltage input to the transducer is supplied with one voltage input terminal. However, we must take into account that the transducer is connected using a PT that is connected line to line. Thus the test will initially start at the default voltage value, that is set in the **Default Setting Screen**, for each Voltage output. However, the V2 output will be 180 degrees out of phase with V1, thus they add across the potential input of the transducer. For example, a default of 120 Volts L-N, means 240 Volts will be impressed across the transducer potential input terminals. Thus V1 will be set to 120 Volts at an angle of  $0^\circ$ , and V2 will be 120 Volts at  $180^\circ$ . I1 and I2 will be in-phase with their respective voltages ( $0^\circ$  and  $180^\circ$ ). When the user inputs the **MAX.** Watts value in the **Transducer Setup Screen**, the firmware can calculate the required test currents for full scale value.

The formula required to calculate Watts for 1 1/2 Element transducer is,

$$V1 * I1 * \text{COS } \emptyset + V2 * I2 \text{COS } \emptyset = W$$

Example: The default voltage is 120.00 VAC, and the user inputs 1000 W as Max. Value. The current required for full scale output from the transducer is,

$$120 * I1 * \text{COS } 0^\circ + 120 * I2 * \text{COS } 0^\circ = 1000 \text{ W}$$

Since each phase contributes half of the power, we can simplify to,

$$I1 = 500 \text{ W}/120 \text{ V}, \text{ or } I1= I2 = 4.1667 \text{ A}$$

Therefore, when the user inputs 1000 W in the **MAX.** value window, in the Test Screen the test set should automatically show a test current value for I1 of 4.167 A at an angle of 0°, and I2 will be 4.167 A at an angle of 180°. Note that the current is rounded up to 7 in the last digit displayed.

When the test is Started, the measured voltage and current outputs are displayed and the calculated Watts is based on the measured voltage and current outputs. This is the value that gets displayed in the **Transducer Test Screen** under the **Output**. Another value of Watts gets calculated using the measured DC V or DC mA output as displayed in the **Transducer Output** section. Let us assume that in our example transducer, the output is in DC mA. For this example, let us say that 1 mA of DC current is equal to the full scale output of 1000 W. Therefore, the theoretical output W from the transducer would be 1000 W, if the output current is 1 mA. For this example, let's say that the measured output voltages are 120.00 V (V1 and V2) and the measured output currents are 4.166 A, at 0°. The measured output W would be,

$$120.00 * 4.166 * \text{COS } 0^\circ + 120.00 * 4.166 * \text{COS } 0^\circ = 999.94 \text{ W}$$

For this example, let's assume the measured output current from the transducer is 0.998 mA DC. Based on a Max. value of 1 mA equals 1000 W, the displayed **W** in the **Transducer Output** section of the **Transducer Test Screen** should read  $1000 * 0.998 = 998.00 \text{ W}$

The **Accuracy** displayed in the **Transducer Output** section would be equal to the following,

$$(998.0 - 999.98/999.98) * 100 = \% \text{ accuracy} \quad \text{or} \quad - 0.198\%$$

If this were a 0.2% transducer, then the firmware would compare the accuracy values between the Setting Screen and the Test Screen and would display **PASS** in the **Transducer Output** section of the test screen.

**Note: All of the calculations are very similar when testing VAR 1 1/2 Element transducers.** The primary difference is replacing the COS function with the SIN function.

#### 3.7.5.4 Watt/VAR 2 Element

This transducer is normally used in three-phase, three wire delta application, which requires 2 voltages and 2 currents to test. Normally, the PT's and CT's are connected to A and C phases. The test set will automatically select two voltage and current channels, **V1, V3, I1** and **I3** (in the event that there is no V3/I3 channel, then V2 and I2 will be used). The test will initially start at the default voltage value, that is set in the **Default Setting Screen**, for each Voltage output. Thus, for a default voltage setting of 120 volts, V1 will be set to 120 V at an

angle of 0°, and V3 will be 120 V at 300° (delta connected PT's). This assumes that the default phase angle is 0 - 360° lag, and not +/- 180°. If the +/- 180° phase angle option is used, then V3 will be at + 60°. I1 and I3 will be phase shifted 30° with their respective voltages, or I1 at 30° lag and I3 at 270° lag (or + 90°). When the user inputs the **MAX.** Watts value in the **Transducer Setup Screen**, the firmware can calculate the required test currents for full scale value.

The formula required to calculate Watts for 2 Element transducer is,

$$V1 * \sqrt{3} * I1 * (\cos 30^\circ + \phi) + V3 * \sqrt{3} * I3 * (\cos 30^\circ - \phi) = \text{Total Watts}$$

Where  $\phi$  is the incremental angular change between V1 and I1 and V3 and I3.

Example: The default voltage is 120.00 VAC, and the user inputs 1000 W as Max. Value. The current required for full scale output from the transducer is,

$$120 * \sqrt{3} * I1 * \cos 30^\circ + 120 * \sqrt{3} * I3 * \cos 30^\circ = 1000 \text{ W}$$

$$I1 = 500 \text{ W} / (120 \text{ V} * \sqrt{3} * \cos 30^\circ), \text{ or } I1 = 500 / 180.00$$

Since I1 = I3, then I1 and I3 will be 2.7777 A each

Therefore, when the user inputs 1000 W in the **MAX.** value window, in the Test Screen the test set should automatically show a test current value for I1 of 2.777 A at an angle of 30°, and I3 will be 2.777 A at an angle of 270° (+ 90°).

When the test is Started, the measured voltage and current outputs are displayed and the calculated Watts is based on the measured voltage and current outputs. This is the value that gets displayed in the **Transducer Test Screen** under the **Output**. Another value of Watts gets calculated using the measured DC V or DC mA output as displayed in the **Transducer Output** section. Let us assume that in our example transducer, the output is in DC mA. In this example, let 1 mA of DC current be equal to the full scale output of 1000 W. For this example, let's say that the measured output voltages are 120.00 V (V1 and V3) and the measured output currents are 2.793 A. The measured output W would be,

$$120.00 * \sqrt{3} * 2.793 * \cos 30^\circ + 120.00 * \sqrt{3} * 2.793 * \cos 30^\circ = 1005.48 \text{ W}$$

For this example, let's assume the measured output current from the transducer is 1.001 mA DC. Based on a Max. value of 1 mA equals 1000 W, the displayed **W** in the **Transducer Output** section of the **Transducer Test Screen** should read  $1000 * 1.001 = 1001.00 \text{ W}$

The **Accuracy** displayed in the **Transducer Output** section would be equal to the following,

$$(1001.00 - 1005.48 / 1005.48) * 100 = \% \text{ accuracy or } - 0.445\%$$

If this were a 0.5% transducer, then the firmware would compare the accuracy values between the Setting Screen and the Test Screen and would display **PASS** in the **Transducer Output** section of the test screen.

If the user adjusts the phase angle in the lagging direction by an additional 30°, then the Watts output changes.

Using the formula,

$$V1 * \sqrt{3} * I1 * (\text{COS } 30^\circ + \emptyset) + V3 * \sqrt{3} * I3 * (\text{COS } 30^\circ - \emptyset) = \text{Total Watts}$$

Where  $\emptyset$  is the incremental angular change of 30° between V1 and I1 and V3 and I 3,

$$120.00 * \sqrt{3} * 2.793 * \text{COS } (30^\circ + 30^\circ) + 120.00 * \sqrt{3} * 2.793 * \text{COS } (30^\circ - 30^\circ)$$

then, Total Watts = 283.7099 + 580.5142 or 864.22 W

**Note: All of the calculations are very similar when testing VAR 2 Element transducers.** The primary difference is replacing the COS function with the SIN function. For the example above,

$$120.00 * \sqrt{3} * 2.793 * \text{SIN } (30^\circ + 30^\circ) + 120.00 * \sqrt{3} * 2.793 * \text{SIN } (30^\circ - 30^\circ)$$

then, 502.7397 + 0 = 502.74 VAR

**Note: For apparent power, VA, transducers, the calculations remain the same, except there are no COS or SIN functions.** For the example above,

$$120.00 * \sqrt{3} * 2.793 + 120.00 * \sqrt{3} * 2.793 = 1161.03 \text{ VA}$$

### 3.7.5.5 Watt/VAR 2 1/2 Element

This transducer is normally used in three-phase, four wire Wye applications, which requires 2 voltages and 3 currents to test. The two voltages and three currents are all referenced to ground. The test set will automatically select two voltage and three current channels, **V1, V3, I1, I2** and **I3**. The test will initially start at the default voltage value, that is set in the **Default Setting Screen**, for each Voltage output. Thus, for a default voltage setting of 120 volts, V1 will be set to 120 Volts at an angle of 0°, and V3 will be 120 Volts at 240° lagging. This assumes that the default phase angle is 0 - 360° lag, and not +/- 180°. If the +/- 180° phase angle option is used, then V3 will be at +120°. I1 and I3 will be in-phase with their respective voltages, or I1 at 0° and I3 at 240° lag (or + 120°). I2 will be at 120° lag (or -120°). When the user inputs the **MAX.** Watts value in the **Transducer Setup Screen**, the firmware can calculate the required test currents for full scale value.

The formula required to calculate Watts for 2 1/2 Element transducer is,

$$V1 * I1 * (\text{COS } \emptyset) + V3 * I3 * (\text{COS } \emptyset) + V1 * I2 * (\text{COS } 60^\circ + \emptyset) + V3 * I2 * (\text{COS } 60^\circ - \emptyset) = \text{Total Watts}$$

Where  $\Delta$  is the incremental angular change between V1 and I1 and V3 and I3, with I2 changing at the same incremental angle as I1 and I3.

Example: The default voltage is 120.00 VAC, and the user inputs 1500 W as Max. Value. The current required for full scale output from the transducer is,

$$120 * I1 * \cos 0^\circ + 120 * I3 * \cos 0^\circ + V1 * I2 * (\cos 60^\circ + 0^\circ) + V3 * I2 * (\cos 60^\circ - 0^\circ) = 1500 \text{ W}$$

$$I1 = 500 \text{ W} / (120 \text{ V} * \cos 0^\circ), \text{ or } I1 = 500 / 120$$

then I1, I2 and I3 will be 4.1667 A each

Therefore, when the user inputs 1500 W in the **MAX.** value window, the test set should automatically show a test current value for I1 of 4.167 A at an angle of  $0^\circ$ , I2 will be 4.167 A at  $120^\circ$  ( $-120^\circ$ ) and I3 will be 4.167 A at an angle of  $240^\circ$  ( $+120^\circ$ ). Note that the current is rounded up to 7 in the last digit displayed.

When the test is Started, the measured voltage and current outputs are displayed and the calculated Watts is based on the measured voltage and current outputs. This is the value that gets displayed in the **Transducer Test Screen** under the **Output**. Another value of Watts gets calculated using the measured DC V or DC mA output as displayed in the **Transducer Output** section. Let us assume that in our example transducer, the output is in DC mA. In this example, let 20 mA of DC current be equal to the full scale output of 1500 W. For this example, let's say that the measured output voltages are 120.02 V (V1 and V3) and the measured output currents are 4.166 A. The measured output W would be,

$$120.02 * 4.166 * \cos 0^\circ + 120.02 * 4.166 * \cos 0^\circ + 120.02 * 4.166 * (\cos 60^\circ + 0^\circ) + 120.02 * 4.166 * (\cos 60^\circ - 0^\circ) = \text{or, } 500.0332 + 500.0332 + 250.0166 + 250.0166 = 1500.10 \text{ W}$$

For this example, let's assume the measured output current from the transducer is 20.1 mA DC. Based on a Max. value of 20 mA equals 1500 W, the displayed **W** in the **Transducer Output** section of the **Transducer Test Screen** should read **1507.5 W**.

The **Accuracy** displayed in the **Transducer Output** section would be equal to the following,

$$(1507.5 - 1500.10 / 1500.10) * 100 = \% \text{ accuracy or } 0.493\%$$

If this were a 0.5% transducer, then the firmware would compare the accuracy values between the Setting Screen and the Test Screen and would display **PASS** in the **Transducer Output** section of the test screen.

If the user adjusts the phase angle in the lagging direction by  $30^\circ$ , then the W output changes.

Using the formula,

$$V1 * I1 * (\text{COS } \emptyset) + V3 * I3 * (\text{COS } \emptyset) + V1 * I2 * (\text{COS } 60^\circ + \emptyset) + V3 * I2 * (\text{COS } 60^\circ - \emptyset) = \text{Total W}$$

Where  $\emptyset$  is the incremental angular change of  $30^\circ$  between V1 and I1 and V3 and I3 etc. ,

then,

$$120 * 4.1667 * \text{COS } 30^\circ + 120 * 4.1667 * \text{COS } 30^\circ + 120 * 4.1667 * (\text{COS } 60^\circ + 30^\circ) + 120 * 4.1667 * (\text{COS } 60^\circ - 30^\circ) = 1299.05 \text{ Total W}$$

**Note: All of the calculations are very similar when testing VAR 2 1/2 Element transducers.** The primary difference is replacing the COS function with the SIN function. For the example above,

$$120 * 4.1667 * \text{SIN } 30^\circ + 120 * 4.1667 * \text{SIN } 30^\circ + 120 * 4.1667 * (\text{SIN } 60^\circ + 30^\circ) + 120 * 4.1667 * (\text{SIN } 60^\circ - 30^\circ) = 1250.01 \text{ VAR's}$$

**Note: All of the calculations are very similar when testing VA 2 1/2 Element transducers.** The primary difference is no COS or SIN functions. For the example above,

$$120 * 4.167 + 120 * 4.167 + 120 * 4.167 = 1500.12 \text{ VA}$$

#### 3.7.5.6 Watt/VAR 3 Element

This transducer is normally used in three-phase, four wire Wye applications, which requires 3 voltages and 3 currents to test. The three voltages and three currents are all referenced to ground. The test set will automatically select three voltage and three current channels, **V1, V2, V3, I1, I2** and **I3**. The test will initially start at the default voltage value, that is set in the **Default Setting Screen**, for each Voltage output. Thus, for a default voltage setting of 120 volts, V1 will be set to 120 V at an angle of  $0^\circ$ , V2 will be 120 V at  $120^\circ$  lagging and V3 will be 120 V at  $240^\circ$  lagging. This assumes that the default phase angle is 0 -  $360^\circ$  lag, and not  $\pm 180^\circ$ . If the  $\pm 180^\circ$  phase angle option is used, then V2 will be at  $-120^\circ$  and V3 will be at  $+120^\circ$ . I1, I2 and I3 will be in-phase with their respective voltages. When the user inputs the **MAX. Watts** value in the **Transducer Setup Screen**, the firmware can calculate the required test currents for full scale value.

The formula required to calculate Watts for 3 Element transducer is,

$$V1 * I1 * (\text{COS } \emptyset) + V2 * I2 * (\text{COS } \emptyset) + V3 * I3 * (\text{COS } \emptyset) = \text{Total Watts}$$

Where  $\emptyset$  is the incremental angular change between V1 and I1, V2 and I2, V3 and I3.

Example: The default voltage is 120.00 Volts AC, and the user inputs 1500 W as Max. Value. The current required for full scale output from the transducer is,

$$120 * I_1 * \cos 0^\circ + 120 * I_2 * \cos 0 + 120 * I_3 * \cos 0^\circ = 1500 \text{ W}$$

$$I_1 = 500 \text{ W} / (120 \text{ V} * \cos 0^\circ), \text{ or } I_1 = 500/120$$

then I1, I2 and I3 will be 4.1667 A each

Therefore, when the user inputs 1500 W in the **MAX.** value window, in the Test Screen the test set should automatically show a test current value for I1 of 4.167 A at an angle of 0°, I2 will be 4.167 at 120° (- 120°) and I3 will be 4.167 A at an angle of 240° (+ 120°). Note that the current is rounded up to 7 in the last digit displayed.

When the test is Started, the measured voltage and current outputs are displayed and the calculated Watts is based on the measured voltage and current outputs. This is the value that gets displayed in the **Transducer Test Screen** under the **Output**. Another value of Watts gets calculated using the measured DC V or DC mA output as displayed in the **Transducer Output** section. Let us assume that in our example transducer, the output is in DC mA. In this example, let 20 mA of DC current be equal to the full scale output of 1500 W. For this example, let's say that the measured output voltages are 120.01 V (V1, V2 and V3) and the measured output currents are 4.167 A. The measured output W would be,

$$120.01 * 4.167 * \cos 0^\circ + 120.01 * 4.167 * \cos 0^\circ + 120.01 * 4.167 * \cos 0^\circ$$

$$\text{or, } 500.0816 + 500.0816 + 500.0816 = 1500.24 \text{ W}$$

For this example, let's assume the measured output current from the transducer is 20.2 mA DC. Based on a Max. value of 20 mA equals 1500 W, the displayed **W** in the **Transducer Output** section of the **Transducer Test Screen** should read **1515.0 W**

The **Accuracy** displayed in the **Transducer Output** section would be equal to the following,

$$(1515 - 1500.24/1500.24) * 100 = \% \text{ accuracy or } 0.984\%$$

If this were a 0.5% transducer, then the firmware would compare the accuracy values between the Setting Screen and the Test Screen and would display **Test Failed** in the **Transducer Output** section of the test screen.

If the user adjusts the phase angle in the lagging direction by 30°, then the Watts output changes.

Using the formula,

$$V_1 * I_1 * (\cos \varnothing) + V_2 * I_2 * (\cos \varnothing) + V_3 * I_3 * (\cos \varnothing) = \text{Total W}$$

Where  $\varnothing$  is the incremental angular change of 30° between V1 and I1, V2 and I2, and V3 and I3 etc. ,

then,

$$120.01 * 4.1666 * \cos 30^\circ + 120.01 * 4.1666 * \cos 30^\circ + 120.01 * 4.1666 * \cos 30^\circ$$

$$\text{or, } 433.0418 + 433.0418 + 433.0418 = 1299.13 \text{ W}$$

**Note: All of the calculations are very similar when testing VAR 3 Element transducers.** The primary difference is replacing the COS function with the SIN function. For the example above,

$$120.01 * 4.1666 * \sin 30^\circ + 120.01 * 4.1666 * \sin 30^\circ + 120.01 * 4.1666 * \sin 30^\circ$$

$$\text{or, } 250.0168 + 250.0168 + 250.0168 = 750.05 \text{ VAR's}$$

**Note: All of the calculations are very similar when testing VA 3 Element transducers.** The primary difference is no COS or SIN functions. For the example above,

$$120.01 * 4.1666 + 120.01 * 4.1666 + 120.01 * 4.1666 = 1500.10 \text{ VA}$$

### 3.7.5.7 Power Factor 3 Element

The three element power factor transducer requires 3 voltages and 3 currents to test. The test set will automatically select the first three voltages and currents channels available, **V1, V2, V3** and **I1, I2, I3**. The test will initially start at the default values for voltage and current that are set in the **Default Setting Screen**. For example, 120 V L-N, 5 A at their respective phase separations of 120° (note that for three phase Power Factor transducers the transducer requires a balanced three-phase output). The calculated Power Factors will be based on the phase separation between V1 and I1. The Power factor transducer has a range of operation that correlates to the Leading or Lagging phase angle relationship between the voltage and current inputs. Therefore, when the user selects Power Factor 3 Element, the **MIN** and **MAX** nomenclature will change to read **LEAD (+)** and **LAG (-)** power factor values. The user is required to input the **LEAD** and **LAG** power factor values into the provided spaces (normally the same values, i. e. 0.5). The power factor is the trigonometric decimal equivalent value of the COS of the angle between the V1 voltage and I1 current. For example, when the user inputs the **LEAD** and **LAG** Power Factor values in the **Transducer Setup Screen**, the firmware can calculate the required test angles for full scale values. Thus for a **LAG** Power Factor value of 0.5, the current would need to lag the voltage by 60°. The Lead and Lag phase angles require that the vector display be changed to show angles as ± 180°. If the default angle representation is 0 to 360° LAG, then the angle between the voltage and current will be considered lagging (current lags voltage). In this situation, the typical test angles may vary between 0 to 90° lag and 359.9 to 270° lag (90° leading). This could cause some confusion to the user. By forcing the display to ± 180° simplifies the testing considerably. The test will start at unity power factor, or ± 0°. Since the default angle will be 0° (zero degrees), the calculation is simple. The formula required to calculate Power Factor is,

$$\cos \angle 0^\circ = 1.000 \text{ Power Factor } (V1 \angle 0^\circ, I1 \angle 0^\circ)$$

Example: The default voltage is 120.00 V and current is 5 A AC, and the user inputs a Power Factor of  $\pm 0.3$  as **LEAD** and **LAG** Values. The angles required for full scale output from the transducer is,

$$0.3 \text{ Power Factor} = \text{COS } 72.5^\circ \text{ or,}$$

$$+ 72.5^\circ \text{ LEAD and } -72.5^\circ \text{ LAG}$$

When the test is Started, the measured voltage and current outputs are displayed and the calculated Power Factor is based on the measured phase angle between the voltage and current outputs. This is the value that gets displayed in the **Transducer Test Screen** under the **Output**.

Another value of Power Factor gets calculated using the measured DC V or DC mA output as displayed in the **Transducer Output** section. Let us assume that in our next example transducer, the output is in DC mA. For this example, let us say that  $\pm 1$  mA of DC current is equal to the full scale Power Factor of  $\pm 0.5$ . Therefore, the theoretical range of output from the transducer would be - 0.5 Power Factor, if the output current is -1 mA, to + 0.5 Power Factor, if the output current is +1 mA. For this example, let's say that the measured output voltage is 120.0 V, at  $0^\circ$ , and the measured output current is 5.000 A, at a lagging angle of  $-30^\circ$ . The calculated Power Factor (displayed next to **Power Factor 3 Element**) would be,

$$\text{COS } -30^\circ = -0.866 \text{ PF}$$

For this example, let's assume the measured output current from the transducer is - 0.489 mA DC. Based on a Lead/Lag value of  $\pm 1$  mA equals  $\pm 0.5$  PF, the scaling would be equal to

$$0.5 \text{ PF} = \text{COS } 60^\circ$$

$$1 \text{ mA}/60^\circ \text{ or } 0.016666 \text{ mA per degree.}$$

Therefore, the displayed **PF** in the **Transducer Output** section of the **Transducer Test Screen** should read

$$-0.489 \text{ mA}/0.016666 \text{ mA/Degree} = -29.35 \text{ Degrees}$$

$$\text{COS } -29.35^\circ = -0.871 \text{ PF}$$

Power factor transducer accuracies are stated in units of Power Factor, not in % error. Therefore, the **Accuracy** window for Power factor transducers needs to change from % error to  $\pm 0.000$  PF. For the above example the **Accuracy** displayed in the **Transducer Output** section would be equal to the following,

$$0.871 - 0.866 = +0.005 \text{ PF}$$

If the accuracy of the transducer were a  $\pm 0.01$  PF, then the firmware would compare the accuracy values between the Setting Screen and the Test Screen and would display **PASS** in the **Transducer Output** section of the test screen.

### 3.7.6 Single Phase Applications

As previously described, transducers come in three-phase and single phase configurations. In the Transducer Setup Screen, the operator is required to select what type of transducer is to be tested. Once selected, the internal firmware will make certain assumptions and calculations based on the type of transducer selected. The following are detailed descriptions of the single phase AC Volts, AC Current, DC Volts, DC Current and Frequency transducers.

#### 3.7.6.1 AC and DC Voltage Transducers

The single phase AC and DC voltage transducer requires 1 voltage output channel to test. The unit will automatically select the first voltage channel available, **V1**. The test will initially start at the default value voltage that is set in the **Default Setting Screen**. For example, 120 Volts L-N. When the user inputs the **MAX**. Volts value in the **Transducer Setup Screen**, the firmware can set the required test voltage for full scale value. Note: to power up the amplifier of some transducers, **V2** may be selected to provide the AC voltage source. Remember to select the proper output voltage for V2 (it will default to the MAX value in the setting screen). If V2 is not available, use another appropriate source.

Example: The default voltage is 120.00 VAC, and the user inputs 150 VAC as Max. Full Scale Value. When the user inputs 150 V in the value window, in the Test Screen the test set should automatically show a test voltage value of 135 V (default is at 90% of Full Scale) at an angle of 0°. Note, the DC voltage transducer is identical, except instead of 50 or 60 Hz as the default output frequency, the display changes to read DC.

When the test is Started, the measured voltage output is displayed. This is the value that gets displayed in the **Transducer Test Screen** under the **Output**. Another value of Volts gets calculated using the measured DC V or DC mA output as displayed in the **Transducer Output** section. Let us assume that in our example transducer, the output is in DC mA. For this example, let us say that 1 mA of DC current is equal to the full scale output of 150 V. Therefore, the theoretical output V from the transducer would be 150 V, if the output current is 1 mA. For this example, the user changed the default 90% to 100%, and let's say that the measured output voltage of the unit is 150.01 V.

For this example, let's assume the measured output current from the transducer is 0.999 mA. Based on a Max. value of 1 mA equals 150 W, the displayed **AC V** in the **Transducer Output** section of the **Transducer Test Screen** should read  $150 * 0.999 = 149.85$  V.

The **Accuracy** displayed in the **Transducer Output** section would be equal to the following,

$$(149.85 - 150.01/150.01) * 100 = \% \text{ accuracy or } - 0.106\%$$

If this were a 0.2% transducer, then the firmware would compare the accuracy values between the Setting Screen and the Test Screen and would display **PASS** in the **Transducer Output** section of the test screen.

**Note: All of the calculations are very similar when testing DC Voltage transducers**

### 3.7.6.2 AC and DC Current Transducers

The single phase AC or DC current transducer requires 1 current to test. The software will automatically select the first current channel available, **I1**. The test will initially start at the default value current that is set in the **Default Setting Screen**. For example, 5 A. When the user inputs the **MAX. Full Scale Current** value in the **Transducer Setup Screen**, the firmware will automatically set the test current for full scale value. Note: to power up the amplifier of some transducers, **V1** may be selected to provide the AC voltage source. Remember to select the proper output voltage for V1 (it will be set to the System Default value in the setting screen).

Example: The default current is 5 A AC, and the user inputs 5 A AC as Max. Full Scale Value. Therefore, when the user inputs 5 A in the **MAX.** value window, the test set should automatically show a test current value of 5.000 A at an angle of 0°. Note, the DC current transducer is identical, except instead of 50 or 60 Hz as the default output frequency, the display changes to read DC.

When the test is Started, the measured test current output is displayed in the **Transducer Test Screen** under the **Output**. Another value of Current gets calculated using the measured DC V or dc mA output as displayed in the **Transducer Output** section. Let us assume that in our example transducer, the output is in DC mA. For this example, let us say that 20 mA of DC current from the transducer is equal to the full scale output of 5 A. Therefore, the theoretical output Current from the transducer would be 5 A, if the transducer output current is 20 mA. For this example, let's say that the measured output current is 5.001.

For this example, let's say that the measured output current from the transducer is 19.9991 mA. Based on a Max. value of 20 mA equals 5 A, the displayed **AC Amperes** in the **Transducer Output** section of the **Transducer Test Screen** should read **4.9997 A**.

If, 20 mA = 5 A or 0.25 A/1 mA

Then, 19.99 mA \* 0.25 A/mA = 4.9975 A

The **Accuracy** displayed in the **Transducer Output** section would be equal to the following,

$(4.9975 - 5.001/5.001) * 100 = \% \text{ accuracy or } -0.0699\%$

If this were a 0.15% transducer, then the firmware would compare the accuracy values between the Setting Screen and the Test Screen and would display **PASS** in the **Transducer Output** section of the test screen.

**Note: All of the calculations are very similar when testing DC Current transducers.**

### 3.7.6.3 Frequency Transducers

The frequency transducer requires 1 voltage output channel to test. The software will automatically select the first voltage channel available, **V1**. The test will initially start at the default value voltage and frequency that is set in the **Default Setting Screen**. For example, 120 V L-N, 60.000 Hz. When the user inputs the MAX. Full Scale Frequency value in the **Transducer Setup Screen**, the firmware will calculate the required test frequency for full scale value.

Example: The default frequency is 60.00, and the user inputs 65 Hz as Max. Value. Therefore, when the user inputs 65 Hz in the **MAX.** value window, the test set should automatically show a test frequency value of 58.50 Hz (90% of Full Scale) at the default voltage value of 120 Volts. To test at Full Scale touch the 90% window and enter 100%. Entering 100% the test frequency will change to Full Scale or 65 Hz.

When the test is Started, the measured voltage and frequency outputs are displayed. The output frequency is the value that gets displayed in the **Transducer Test Screen** under the **Output**. Another value of Frequency gets calculated using the measured dc Volts or dc mA output as displayed in the **Transducer Output** section. Let us assume that in our example transducer, the output is in dc Volts. For this example, let us say that 10 VDC is equal to the full scale output of 65 Hz. Therefore, the theoretical output Frequency from the transducer would be 65 Hz, if the transducer output voltage is 10 VDC. For this example, let's say that the measured output frequency is 65.00 Hz., and the measured transducer output voltage is 10.001 V. The measured transducer output Frequency would be,  
If,  $65.00 \text{ Hz} = 10 \text{ VDC}$

Then,  $65/10 = 6.5 \text{ Hz/V}$

$V * 6.5 \text{ Hz/V} = 65.0065 \text{ Hz}$

For this example, the displayed **Hz** in the **Transducer Output** section of the **Transducer Test Screen** should read 65.000 Hz.

The **Accuracy** displayed in the **Transducer Output** section would be equal to the following,

$(65.0065 - 65.000/65.000) * 100 = \% \text{ accuracy or } -0.01\%$

If this were a 0.02% transducer, then the firmware would compare the accuracy values between the Setting Screen and the Test Screen and would display **PASS** in the **Transducer Output** section of the test screen.

## 3.8 Meter Test

The Meter Test provides a quick and easy approach to testing the metering function of protective relays. To access the Meter Test, click on the Meter icon  in the Standard side of the Test list. The following test screen will appear.

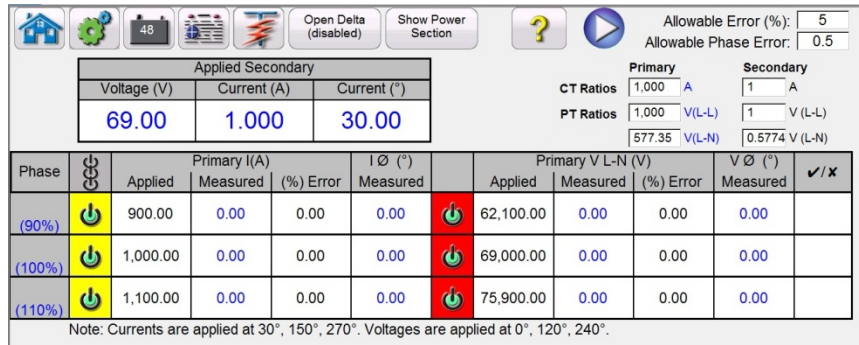



Figure 206 Meter Test Screen

The user simply selects the output channels like the manual vector test screen. Values can be in secondary (default) or Primary by clicking on the Primary Ratios windows and entering the CT and VT ratios (see Primary Ratios in the Configuration screen section for details). Enter the desired allowable error in % of reading in the window provided (be sure to take into consideration that this is the total error of the test set plus the error of the relay). Turn the outputs on by clicking on the All ON/All OFF

button . Press or click on the Show Power Section to reveal the power measurements as shown in the following figure. Read and enter the metered values from the relay into the windows provided.

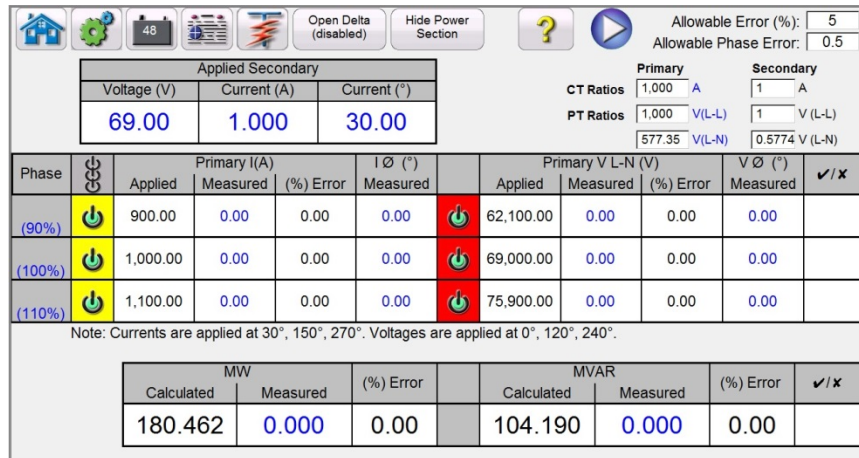



Figure 207 Meter Test with Power Measurements

If testing the metering in an SEL relay using serial communication to download the meter values, press the blue Run Test  button. And the following figure will appear.

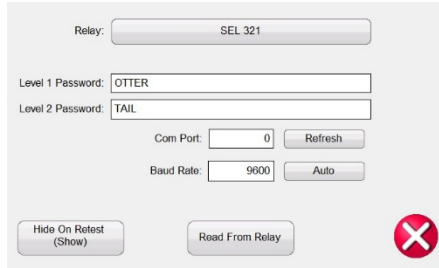





Figure 208 SEL Serial Communication Screen

Select the appropriate relay by pressing the Relay button (defaulted to SEL 321). Press the **Read from Relay** button to automatically download the meter values.

The software will automatically calculate the percentage error. Click on the test report  button to add the Meter test results to the test report.

### 3.9 Testing Differential Relays

The Differential Relay provides a quick and easy approach to testing three-phase Transformer, Motor, Generator, and single-phase Transformer, differential relays.

To access the Differential Relay Test, press the Select New Test button  next to the Relay Settings  button. Press the 3 Phase Transformer Differential Relay  button to open the 3 Phase Transformer Nameplate screen to enter information for the relay to be tested. It should be noted that the 1 Phase Transformer Differential settings screen is almost identical except for the Change Connections buttons Labeled **Use I1,2,3** and **Use I4,5,6** changes to **Use I1** and **Use I2**, respectively. There are two models to choose from, ANSI and IEC. You will find the selection button at the bottom left side of the window. Press the button to toggle between ANSI and IEC transformer models. Each model will present a transformer graphic commonly used for either North American, or European, style transformer protection. The values entered in the Transformer Nameplate will determine what values of current and phase angle relationships are applied to the relay in the tests.

 **Special Test Application Note:** In the General Settings section of the System Configuration Screen, there is a button labeled **Multi-Instances**. This button allows the user to select multiple Differential relays to test and combine into one test result file. For example, some generator differential protection relays also include transformer differential protection. With the Multi-Instances button enabled, when the user selects the Differential test, they will see a list button to select the number of Instances (relays) they want to include in the test report.

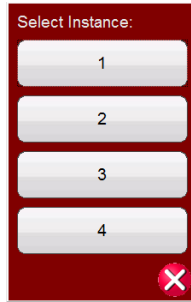

Figure 209 Select (number of) Instances.

For the example above, press 1 then select the first type of differential you want to test, i.e., 3 Phase Generator Differential. Input relay settings. Run the entire test that you want for the relay. Then select the Home button and select the Select New Test button. For the second relay type i.e., 3 Phase Transformer Differential, press 2. Input relay settings. Run the entire tests for the second differential. When finished, press the Report Options button and all the tests that were conducted will be listed by pages in the sequence in which they were performed.

### 3.9.1 Transformer Nameplate

The top half is the transformer model where the user selects the Transformer Primary and Secondary winding configurations, enters the Primary and Secondary Voltages ratings, CT ratios, the transformer MVA rating, enters the single-phase pickup factor, selects if there are interposing CT's (and their associated CT Multiplier values), and enables I<sub>0</sub> (zero sequence) elimination when applicable. In the bottom half is the relay settings, bias equation selection window and slope selection window. Once these settings are entered, the software will automatically calculate and display the base currents in primary and secondary values for each winding. Note that throughout the tests, only secondary currents are considered. Primary currents will only be shown for informational purposes. These secondary base current values will be used to compute Ampere – Per Unit conversions.

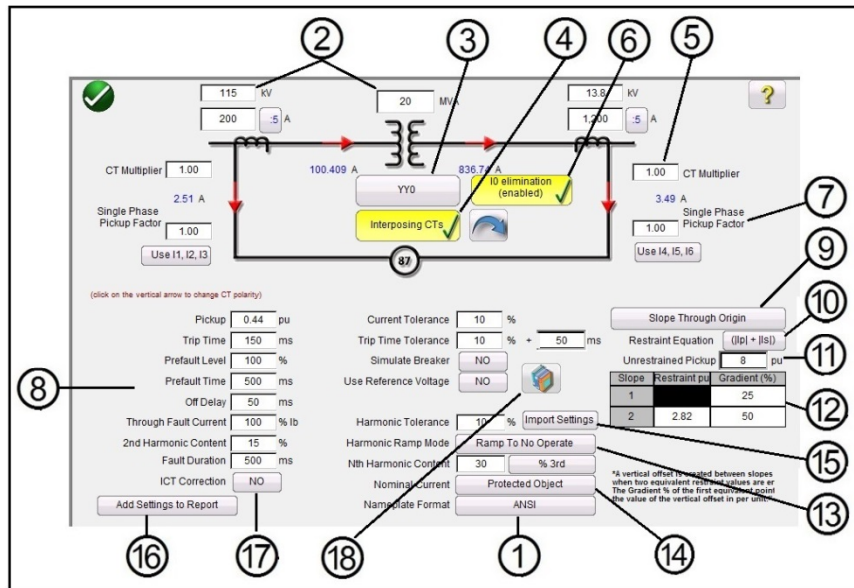

Figure 210 ANSI Transformer Nameplate Model with Interposing CT's and Io Elimination Selected

By entering the known values for the transformer and CT configurations the software will automatically calculate the appropriate three phase primary and secondary current values for testing the relay under test.

- ① Transformer Model Selection- Press to select the desired test model. Toggles between ANSI and IEC models.
- ② Enter the Transformer's Primary and Secondary voltages, MVA rating, and the Primary and Secondary Current Transformer data as specified by the relay. This includes CT ratios, CT polarities etc. If required, press, or click on the vertical arrows to change CT polarity directions on both windings.
- ③ Transformer Configuration  Selection Button- Press or click on the transformer configuration selection button to access the available selections for the primary and secondary winding configurations. Pressing on the button will provide the Primary Winding Selection box.



Figure 211 Primary Winding Selection Box

Press or click on the appropriate button that represents the primary winding. Available selections are Y, Yn (grounded Y), D (delta), Dn (grounded Delta), Z, Zn (grounded Z), or Compensated CT's. The letter 'n' signifies a neutral/earthed star-point in which a 1.5 constant will be applied to the single-phase tests. This is required for elimination of any zero sequence currents introduced when testing single phase to ground faults. The Compensated CT's selection tells the software to simulate externally connected CT's that perform all magnitude and phase compensation, therefore, no compensation, whether magnitude or phase will be applied internally by the software. After selecting the Primary Winding the Secondary Winding Selection Box will appear.

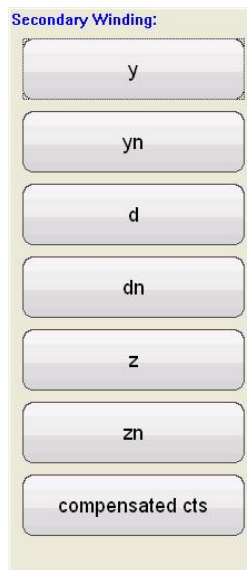



Figure 212 Secondary Winding Selection Box

Press or click on the appropriate button that represents the secondary winding. Available selections are y, yn (grounded Y), d (delta), dn (grounded Delta), z, zn (grounded Z), or compensated CT's. The Compensated CT's selection tells the software to simulate externally connected CT's that perform all magnitude and phase compensation, therefore, no compensation, whether magnitude or phase will be applied internally by the software. After selecting the Secondary Winding, the Winding Clock Reference Selection Box will appear. Depending on your selection of the primary and secondary windings will determine which clock reference screen will appear. Your choices are 1,3,5,7,9, or 11 o'clock if using a combination of Y, Delta, or Z selections, or for Y – y/Delta – delta selections your choices are 0, 2, 4, 6, 8, 10, or 12 o'clock.

④ The Interposing CT's  button should be selected when interposing CTs are connected to the HV and LV windings of the relay and are responsible for all Phase/Magnitude correction/compensation, and possible zero sequence (I<sub>0</sub>) elimination. When selecting interposing CT's the CT Multiplier window, item ⑤, will appear for the user to enter any appropriate CT multiplier values. The phase rotation of the output currents simulating the interposing CT's can be altered by pressing the arrow button. It will toggle between clockwise and counterclockwise rotation.

 When selecting Interposing CT's, the Power System Vector Group Configuration should be selected based on this sample range of settings. For example, a Reyrolle MIB202 Numerical Bias Differential Relay with the following Interposing CT's Selection; HV (Yd1, - 30°) and LV (Yy0, 0°) requires a Vector Group Selection of Yd1, YNd1. Consult the relay manufacturer's instructional information to verify the appropriate vector group to be used for other possible Interposing CT Selections. If the manufacturer's information is not available, the following guide is provided to assist the user in selecting an appropriate Transformer Vector Group.

### Transformer Vector Groups and Interposing CT Selection Guide

Transformer Vector Groups	HV Interposing CT Selection	LV Interposing CT Selection
YNy0, Yy0, Ydy0, Yndy0, Yyn0, YNyn0, Ydyn0, Yndyn0, Dz0	Ydy0, 0°	Ydy0,0°
Yd1,YNd1	Yd1, -30°	Yy0,0°
Yd1, YNd1 + Grounding (Earthing) Transformer	Yd1, -30°	Ydy0,0°
YNy2, Yy2, Ydy2, Yndy2, Yyn2, YNyn2, Ydyn2, Yndyn2, Dz2	Ydy2, -60°	Ydy0,0°
Yd3,YNd3	Yd3, -90°	Yy0,0°
Yd3, YNd3 + Grounding (Earthing) Transformer	Yd3, -90°	Ydy0,0°
YNy4, Yy4, Ydy4, Yndy4, Yyn4, YNyn4, Ydyn4, Yndyn4, Dz4	Ydy4, -120°	Ydy0,0°
Yd5,YNd5	Yd5, -150°	Yy0,0°
Yd5, YNd5 + Grounding (Earthing) Transformer	Yd3, -150°	Ydy0,0°
YNy6, Yy6, Ydy6, Yndy6, Yyn6, YNyn6, Ydyn6, Yndyn6, Dz6	Ydy6, -180°	Ydy0,0°
Yd7,YNd7	Yd7, -150°	Yy0,0°
Yd7, YNd7 + Grounding (Earthing) Transformer	Yd7, -150°	Ydy0,0°
YNy8, Yy8, Ydy8, Yndy8, Yyn8, YNyn8, Ydyn8, Yndyn8, Dz8	Ydy8, 120°	Ydy0,0°
Yd9,YNd9	Yd9, 90°	Yy0,0°
Yd9, YNd9 + Grounding (Earthing) Transformer	Yd9, 90°	Ydy0,0°
YNy10, Yy10, Ydy10, Yndy10, Yyn10, YNyn10, Ydyn10, Yndyn10, Dz10	Ydy10, 60°	Ydy0,0°
Yd11,YNd11	Yd11, 30°	Yy0,0°
Yd11, YNd11 + Grounding (Earthing) Transformer	Yd11, 30°	Ydy0,0°
Dy1, Dyn1	Yy0, 0°	Yd11, 30°
Dy1, Dyn1 + Grounding (Earthing) Transformer	Ydy0, 0°	Yd11, 30°
Dy3, Dyn3	Yy0, 0°	Yd9, 90°
Dy3, Dyn3 + Grounding (Earthing) Transformer	Ydy0, 0°	Yd9, 90°
Dy5, Dyn5	Yy0, 0°	Yd7, 150°
Dy5, Dyn5 + Grounding (Earthing) Transformer	Ydy0, 0°	Yd7, 150°
Dy7, Dyn7	Yy0, 0°	Yd5, -150°
Dy7, Dyn7 + Grounding (Earthing) Transformer	Ydy0, 0°	Yd5, -150°
Dy9, Dyn9	Yy0, 0°	Yd3, -90°
Dy9, Dyn9 + Grounding (Earthing) Transformer	Ydy0, 0°	Yd3, -90°
Dy11, Dyn11	Yy0, 0°	Yd1, -30°
Dy11, Dyn11 + Grounding (Earthing) Transformer	Ydy0, 0°	Yd1, -30°

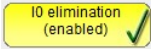
- ⑥  button – Press the button to enable the zero-sequence elimination feature. For relays with neutral/earthed star-point connections, a 1.5 constant will be applied to the single-phase tests. This is required for elimination of any zero sequence currents introduced when testing single phase to ground faults. If the relay being tested does not adopt this approach, then Io elimination should be disabled.



It should be noted that some relay manufacturers have different zero sequence correction factors for single-phase faults, where the default constant of 1.5 does not apply (depending upon the transformer vector group see item ③ above for even and odd vector groups). For example, single-phase faults in Siemens 7UT613 relay the even number vector groups' use 1.5, while the odd number vector groups' use 1.73. Consult the relay manufacturer's instructional information to verify the pickup factors to be used. If you use a correction factor other than 1.5, you will need to disable the Io elimination and manually enter the appropriate factor in the window provided.

- ⑦ Single Phase Pickup Factor - Once the vector groups are selected, the single-phase pickup factors required to run single phase pickup tests are predetermined. If these settings do not match the relay's compensation factors, then the values should be adjusted from the input fields provided.



It should be noted that some of the relay manufacturers adopt their own pickup factors. Consult the relay manufacturer's instructional information to verify the pickup factors to be used.

- ⑧ Relay and Test Settings – The values entered will be used to perform the tests and evaluate the results. Consult the relay manufacturer's instructional information to verify the settings and tolerances.

**Pickup and Pickup Tolerance:** Enter the appropriate Per Unit value for the pickup value, and its associated tolerance.

**Trip Time and Trip Time Tolerance:** Enter the appropriate trip time of the relay, and its associate tolerance.

**Prefault Level:** Is set in percent of Full Load Current as seen by the relay. Pick up and slope tests are performed using Pulse Ramp. This current will be applied to the relay prior to each pulse ramp increment for the Prefault Time duration.

**Prefault Time:** Is set in ms. This will be the period that the Prefault currents will be applied prior to applying test values.

**Off Delay:** Is a time value set in ms. When the relay operates, the software will extend the fault current for the off delay time entered to simulate the time delay associated with the breaker opening before the outputs go to zero. This is used for relays that sense for breaker failure by detecting the presence of fault current after issuing a trip. Enter the

opening time of the breaker associated with the transformer being protected. If the operating time is unknown use the default time of 50 ms.

**Through Fault:** Is set in percent of Full Load Current as seen by the relay on both the primary and secondary sides of the transformer.

**2<sup>nd</sup> Harmonic Content:** Enter the % of second harmonic restraint set in the relay.

**Fault Duration:** Is set in ms. This will be the time that the incremental “fault” current will be applied to the relay during the pickup, slope, and harmonic restraint tests. Set the duration time long enough for the relay to operate or leave at the default value.

**Harmonic Tolerance:** Is set in percent value, used to evaluate the pickup of the 2<sup>nd</sup> harmonic restraint element.

**Nth Harmonic Content:** For relays with more than one harmonic restraint, enter the order of the harmonic by pressing or clicking on the harmonic selection button, then press or click in the % window to enter the percent value of the harmonic.

⑨ Slope Characteristic Selection Button: Pressing this button will provide the following selection windows.



Figure 213 Slope Characteristics Selection Menu

The slope characteristics vary by manufacturer design. Five options provided cover the various designs. In addition, slope characteristics are also determined by the following settings.

**Pickup value:** This represents the lower flat line of the graph and is the minimum differential current required for the relay to trip.

**Unrestrained Pickup value**

**Slope 1, and 2** start points and gradients (start points and gradients 3 and 4 appear when selecting Line Segments)

**Slope setting.**

**I Bias equation setting.**

**Line Segments:** The Line Segments option allows for any slope characteristic design with up to four segments. When Line Segments is selected the window provides up to four slope options. Setting values vary such as knee points and % slope. Check relay settings for actual setting values.

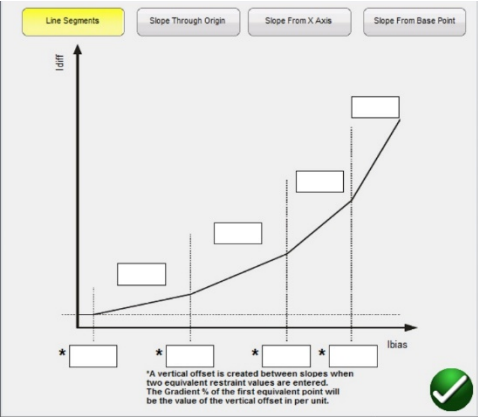

Enter knee point and slope values for each segment.

**Slope Through Origin:** The line starts at the origin and rises at the Gradient % setting. Slope Line 1 segment is defined by where the Slope 1 line intersects with the Minimum Pickup (represented by the lower flat line of the graph) and stops at the Slope Line 2 segment IBias (p.u.) setting in the Slope Line Segment window.

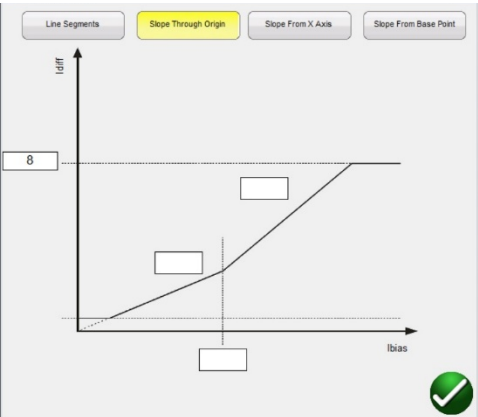

**Slope From X Axis:** The line starts on the X Axis at the I restraint (pu) value entered in the Line Segment window and rises at the Gradient % setting. Slope Line 1 segment is defined by where the Slope 1 line intersects with the Minimum Pickup (represented by the lower flat line of the graph) and stops at the Slope Line 2 segment IBias (p.u.) setting in the Slope Line Segment window.

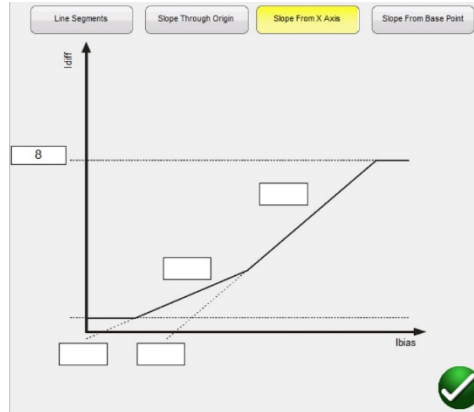

**Slope From Base Point:** The Slope 1 line segment starts where the X Axis I restraint (pu) value entered in the Line Segment window intersects with the Minimum Pickup (represented by the lower flat line of the graph) and rises at the Gradient % setting. Slope Line 1 segment stops where at the Slope Line 2 segment IBias (p.u.) setting in the Slope Line Segment window.

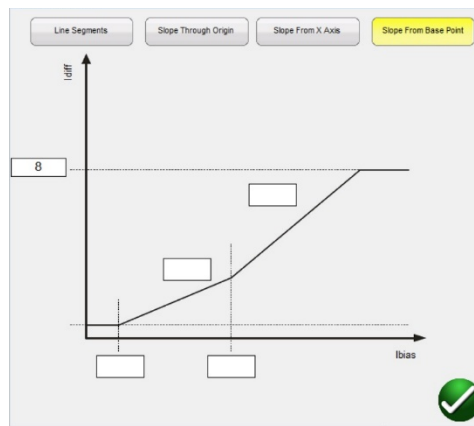

**Cubic Spline:** This characteristic is normally associated with the G.E. T60 or T35 relays. The Slope 1 and 2 settings express the slope of the operating characteristic as a function of differential current ( $I_d$ ) and restraint current ( $I_r$ ). The Slope 1 line segment starts near the Pickup point and rises at the % slope gradient to Breakpoint 1. From Breakpoint 1 to Breakpoint 2 is the Cubic Spline Transition Region. Slope 2 starts at Breakpoint 2 and rises at the % slope gradient.

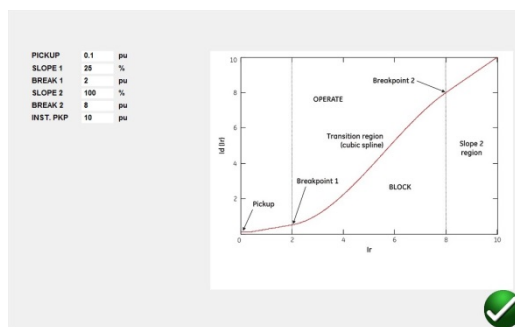

⑩ IBias Equation: Pressing or clicking on the button will present the user with a list of nine different biasing (restraint) equations. Different relay manufacturers use different methods for restraining the operation of the differential element. Consult the relay manufacturer's instructional information to verify which equation to use. The following are some example relays and associated equations.

Equation	Manufacturer
$( I_p  +  I_s )$	SEL 487, SEL 787, Siemens 7UT5X and 7UT6X Series
$( I_p  +  I_s )/2$	SEL 387, SEL 587
Max $ I_p $ or $ I_s $	ABB RET670, GE Multilin SR 745
$(I_p + I_s - I_{diff})/2$	ZIV

⑪ Unrestrained Pickup: Enter the appropriate value for the unrestrained pickup in Per Unit.

⑫ Slope Characteristic Line Segment Definition Table: Depending on which Slope Characteristic was chosen, see ⑨ above, the number of slope lines will vary from 2 to 4, and the IBias pickup values will vary depending on whether the slope goes through the Origin or not. See the line descriptions above for examples.

⑬ Harmonic Ramp Mode: User may select to ramp the percent of harmonic content in the fundamental up until the relay goes into restraint (Ramp To No Operate), or down to decrease the percent of harmonic until the relay drops out of restraint (Ramp To Operate).

⑭ Nominal Current: Press or click on the button to toggle between Current Transformer and Protected Object. Use to select either the calculated tap values, or the rated secondary current of the CT (use as balanced vector magnitudes during the stability test). If Protected Object is selected, W1/W2 magnitudes will be calculated from MVA, kV, and CT settings. If Current transformer is selected, W1/W2 magnitudes will be set at the rated secondary current of the CT, i.e., 1 or 5 A.

⑮ Import Settings: Click here to access differential relay settings and import into the differential relay test template in XML file format. This feature is like the Impedance relay import of relay settings. It is designed to speed up the testing of differential relays and reduce errors. Presently imports the ZIV relay settings.

⑩ Add Settings to Report: Press or click on this button to include the relay settings into the test report.

⑪ ICT Correction button is used when testing Reyrolle Duo bias transformer protection relays with interposing current transformers. When the IEC model ① is selected, and the Interposing CT's ④ is selected, and the ICT Correction ⑪ button is selected Yes, RTMS will recalculate the CT Multiplier value using the ICT Correction. This calculation is used in all tests except the Stabilization test.

⑫ Relay Library button 

Pressing the Relay Library button will provide a library of relay specific characteristics by various manufacturers. Selection from the list will automatically populate the appropriate Slope Characteristic, IBias Equation, and Slope Characteristic Line Segment Definition Table. The user may need to change some of the defaulted values such as % Gradient settings, to fit the relay under test.

### 3.9.2 Transformer Differential Tests

When all the transformer and relay settings have been entered, press or clicks on the green check mark. The user will be taken to the first test screen, the Stabilization Test. To see a list of all the tests available, press or click on the Test List  button.

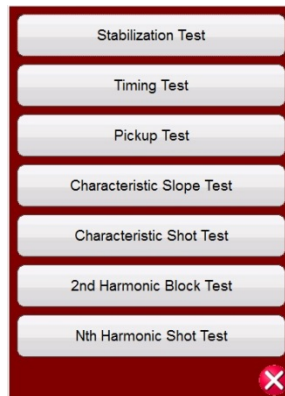





Figure 214 Test List

The user may select to perform any individual test by pressing the desired test button. After selection of the test, to execute any selected test press or click on the Blue Play . Press or click on the Play All  button and a list will be provided; Run All (Selected) Tests, Run All Remaining (Selected) Tests, Run All Differential Tests, or Run All Remaining Differential Tests.

The following is a description of each test.

### 3.9.2.1 Stabilization Test

The stability test verifies the relay being tested is stable for external 3-phase faults. Settings that affect stability test are:



- Power transformer, current transformer, vector group combination settings: these settings will determine the correct magnitude and phase angles to be injected on all phases for both windings of the relay.
  - Through Fault level- this sets the through fault percentage of the balanced currents applied to the relay. Setting this to 100% will inject 1x the rated current of winding1 and winding2. Setting this to 200% will inject 2x those values.
  - Nominal Current in Use – The software will apply either the calculated tap values or the rated secondary current of the CT as balanced vector magnitudes during the stability test. If Protected Object is selected, W1/W2 magnitudes will be calculated from MVA, kV, and CT settings. If Current transformer is selected, W1/W2 magnitudes will be set the rated secondary current of the CT i.e., 1 or 5.
1. Connect the appropriate output terminal(s) for the selected channel(s) to be used.
  2. Connect the desired Binary Input terminal to sense the relay trip contacts. Press the selected Binary Input. If the Binary Input is already set to **Use as Trip (enabled)**, select for the appropriate sensing Normally Open, Normally Closed, Voltage Applied, or Voltage Removed.
  3. Press or click on the Blue Play  button to run stability test. This will inject the balanced 3 phase currents based upon the Transformer and Vector Group settings. For a stable condition, the relay is not expected to trip. Enter the metered values from the relay and observe that they correspond to the injected values. Press or click on the Finish/Abort button (if the injected values do not correspond, press, or click on Simulate Contact or Force Failure buttons). Note that the relay might not trip if the differential function has been turned off, or the injected values are not sufficient to produce the minimum differential current (this is also considered as a failed test even if the relay does not trip).

If the relay trips instantaneously, verify nameplate settings correspond to relay settings, verify connections are correct etc. To View the test result, press the Add to Reports  button.

### 3.9.2.2 Timing Test

Timing test verifies the relay being tested operates at the expected trip time for internal three phase faults or internal phase to earth faults. Settings that affect timing test are:

- Power transformer, current transformer, vector group combination settings: these settings will determine the correct magnitude and phase angles to be injected on all phases for both windings of the relay.

- Trip time – This is the expected trip time for the relay to operate. This value should be verified from the relay. If the relay does not trip, the software will inject the fault vector for two\* the expected trip time and then automatically stop the test.
  - Prefault Level/Prefault Duration – these values configure the prefault vector that will be injected before fault vectors are applied.
1. Connect the appropriate output terminal(s) for the selected channel(s) to be used.
  2. Connect the desired Binary Input terminal to sense the relay trip contacts. Press the selected Binary Input. If the Binary Input is already set to **Use as Trip (enabled)**, select for the appropriate sensing Normally Open, Normally Closed, Voltage Applied, or Voltage Removed.
  3. Press or click on the Blue Play  button to run the Timing Tests. For the single phase tests, the fault vector will be applied on the phase being tested, while balanced (prefault) current vectors will be applied across the other phases. For the three phase tests, the test set will inject the fault vectors across all six phases.
  4. To View the test result, press the Add to Reports  button.

### 3.9.2.3 Pickup Test

The pickup test verifies the minimum operating current of the differential relay. The test is performed using a Pulse Ramp, which applies the appropriate prefault value before the Ramping begins. The Pulse Ramp will return to the Prefault condition between each increment. Based on the settings of the relay, the Pulse Ramp begins at 85% of the expected pickup value, applying the prefault and fault vectors appropriately until the relay trips. If this trip signal is detected within the tolerance ranges of the relay, a pass message will be displayed. If on first injection a trip signal is detected the ramp will return to 50% of the expected pickup value and run from there. If a trip signal is detected at 50% then a failure message is displayed.



Considerations to make before running the pickup test.

- During the single-phase test, the selected vector group would have defined the single-phase pickup factors that will be used for the test. It is imperative that these values match the values that are specified by the relay manufactures' manual (Relay manufacturers may sometime defer from the Differential standard single-phase pickup factors).
- During the single-phase test, if the selected vector group has an earthed star-point on either or both windings, it is essential to select if the relay compensates for zero sequence currents introduced by the phase to ground fault. When zero sequence (I<sub>0</sub> elimination) is enabled a 1.5 factor is introduced to eliminate any zero sequence currents. If the relay does not perform zero sequence elimination this factor is not needed and should be disabled.
- During the three-phase test, the selected vector group would have defined the phase compensation values across all 6 phases. It is imperative that the vector group selected matches the vector group on the relay settings.

Settings that affect Pickup test

- Power transformer, current transformer, and vector group combination settings determine the tap current, which will be used to convert the Per Unit value to actual Amperes that is injected into the

relay. The vector group settings will determine the single-phase pick-up factors, which adjusts the Ampere value injected to compensate the vector magnitudes based on a wye, delta, or zigzag-connected transformer.

- Pickup – This is minimum pickup Per Unit value required for the relay to operate. The search routine will begin from 85% of the minimum pickup and pulse ramp until it finds the operating point. If this value is not entered correctly in the settings screen, the search routine will be performed incorrectly.
  - Prefault Level/Time – these values configure the prefault vector that will be injected before any fault vectors.
  - Fault Duration – this setting defines the number of ms the fault vector will be applied. Make sure that this value is slightly more than the operating time of the relay to insure that the test set will see the trip contacts pickup.
1. Connect the appropriate output terminal(s) for the selected channel(s) to be used.
  2. Connect the desired Binary Input terminal to sense the relay trip contacts. Press the selected Binary Input. If the Binary Input is already set to **Use as Trip (enabled)**, select for the appropriate sensing Normally Open, Normally Closed, Voltage Applied, or Voltage Removed.
  3. Press or click on the Blue Play  button to run the Pickup Test. A menu list will be presented to the user to select which winding to test. For the single phase tests, the fault vector will be applied on the phase being tested, while balanced (prefault) current vectors will be applied across the other phases. For the three phase tests, the test set will inject the fault vectors across all 6 phases.
  4. To View the test result, press the Add to Reports  button.

#### 3.9.2.4 Slope Test

The slope test verifies the bias differential characteristic of the relay. For each value of the bias (restraint) value selected, a search-line routine finds the value of the pickup point necessary for the relay to operate. These values are plotted on the characteristic graph.

##### Settings that affect the Slope Test

- Power transformer, current transformer, vector group combination settings: these settings will determine the tap current, which will be used to convert the PU value to actual Amperes that is injected into the relay. The vector group settings will determine the phase compensation to be applied during the 3-phase fault test. The phase angles will be adjusted automatically during the search routine based on the clock group selected.
- I Bias Equation – the current magnitudes injected to the relay are calculated based on the bias formula the relay uses. The primary (I1) and secondary (I2) currents are calculated from Id and Ir simultaneously. Consequently, it is imperative the I Bias Equation selection matches the equation specified by the relay being tested.
- Slope setting – This defines the way the characteristic is drawn. It is important to select the appropriate slope settings to draw the appropriate theoretical characteristic for the relay.

- Prefault Level/Time – these values configure the prefault vector that will be injected before any fault vectors.
- Fault Duration – this setting defines the number of cycles the fault vector will be applied for.

### Creating Search Lines

Upon selecting the Slope Test the user will be taken to the Slope Test Screen, which includes the graphic display of the relay Slope Characteristic. Click in the characteristic window to create a search line associated with the slope characteristic. The following is an example with four test lines drawn.

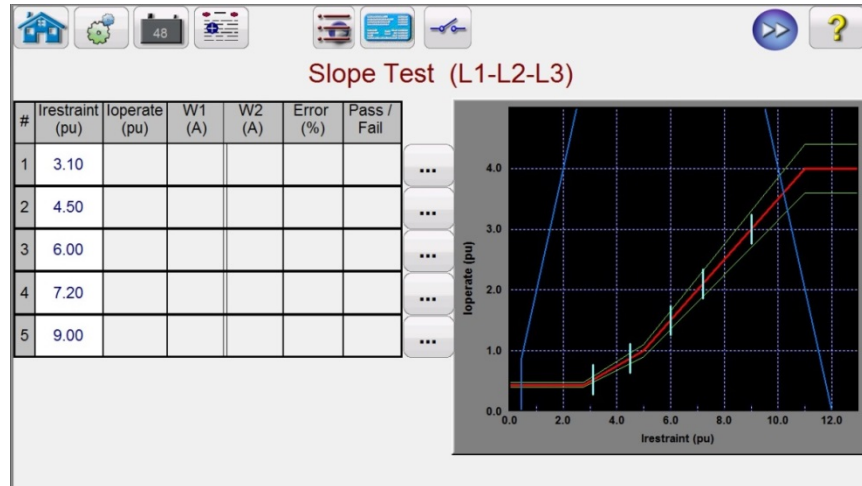

Note the blue limit lines in the above figure. This Slope Test Screen is based upon using a SMRT410 with 6 current channels capable of providing up to 60 A each. Therefore, there is no limit regarding the operating and restraint currents. If using a SMRT36/46 or SMRT36D/46D with the voltage channels converted to currents, a blue limit line will appear from the right side of the graphic which may cross the upper portion of the slope characteristic depending upon the relay settings. The second blue line indicates the limits regarding the maximum output current from the convertible channels and shows area of the slope characteristic that can be tested.

If you mistakenly enter a test line and want to delete it press or click on the Run Edit  button associated with the selected test #. The user will see a list of actions that can be done. One of the actions is Delete. Pressing the Delete button, the software will ask you to confirm that you want to delete the test(s).

1. Run all tests by either pressing or clicking on the Blue Play  button. To run individual tests, press or click on the Run Edit  button for the individual tests. When the test starts a red arrow test line will start ramping up the search line. Once the arrow enters the acceptable tolerance line the arrow will change color to green. When the relay operates, if the test point is within the acceptable min/max tolerance lines a green dot will appear, the % error will be displayed in the test table along with Pass declaration, and the test will move onto the next

test line. If the test point is outside the acceptable tolerance a red X will appear, the % error will be displayed in the test table with the Fail declaration.

- To View the test result, press the Add to Reports  button.

### 3.9.2.4.1 Characteristic Shot Test

The Characteristic Shot Test is like the Slope Test. However, instead of drawing test lines the user simply clicks above and below the characteristic line.

#### Creating Test Points

Upon selecting the Characteristic Shot Test, the user will be taken to the Slope Test Screen, which includes the graphic display of the relay Slope Characteristic. To create test points, click in the characteristic window above and below the slope characteristic. The following is an example with six test points, three above and three below the slope line.

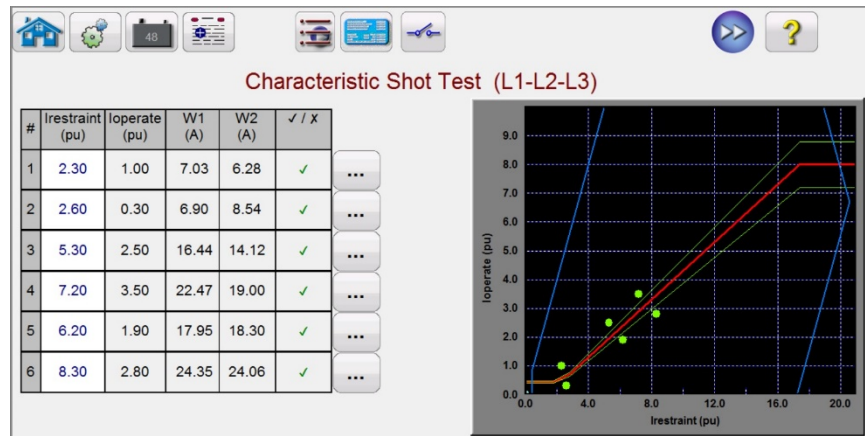

Figure 215 Slope Characteristic Shot Test Screen

Execute the test like the Slope Test described above.

### 3.9.2.5 Harmonic Block Test

The harmonic block test verifies the proper operation of the harmonic restraint element of the relay. The test is based upon the 2<sup>nd</sup> Harmonic Content (and/or Nth Harmonic Content) and Harmonic Tolerance entered in the settings. In the test screen the user can select individual phases for test as well as three phase tests, either Primary or Secondary side of the transformer.

The Harmonic Block test is performed by applying a fundamental current equal to the Pickup setting, which will cause the relay to operate and close the trip contacts. The harmonic content will slowly be ramped up increasing the percent of harmonic until the relay goes into restraint. At that point, the percentage of harmonic is recorded.



#### Settings that affect the Harmonic Block test

- Power transformer, current transformer, and vector group combination settings determine the tap current, which will be used to convert the Per Unit value to actual Current that is injected into the relay. This will be the fundamental current applied at the start of the test.

- Prefault Level/Time – these values configure the prefault vector that will be injected before any fault vectors.
  - Fault Duration – this setting defines the number of ms the fault vector will be applied. Make sure that this value is slightly more than the operating time of the relay to insure that the test set will see the trip contacts pickup.
  - Harmonic Content – The search routine will begin from 85% of the expected restraint value and ramp the harmonic content up until it finds the restraint point. If this value is not entered correctly in the settings screen, the search routine will be performed incorrectly.
  - Harmonic Tolerance – This value is used to determine Pass/Fail.
1. Connect the appropriate output terminal(s) for the selected channel(s) to be used.
  2. Connect the desired Binary Input terminal to sense the relay trip contacts. Press the selected Binary Input. If the Binary Input is already set to **Use as Trip (enabled)**, select for the appropriate sensing Normally Open, Normally Closed, Voltage Applied, or Voltage Removed.



Application Note: The Prefault values will be applied prior to applying the harmonic block test. Make sure that all three-phase outputs are connected to the relay under test. When the ramp starts the PU Tap current will be applied, thus the relay will close the trip contacts. Therefore, set the binary input to sense Normally Closed (Trip) contacts to Open (Restraint). If using wetted contacts set the binary input to sense Voltage Removed.

3. Press or click on the Blue Play  button to run the Harmonic Block Test. A menu list will be presented to the user to select which winding to test. For the single phase tests, the test current will be applied on the phase being tested, while zero current will be applied across the other two phases. For the three phase tests, the test set will inject the fault vectors across all 3 phases on the desired Winding (Primary or Secondary).
4. To View the test result, press the Add to Reports  button.

### 3.9.2.6 Harmonic Shot Test

The harmonic shot test is a GO/NO GO test to quickly verify the proper operation of the harmonic restraint element of the relay. The test is based upon the 2<sup>nd</sup> Harmonic Content (and/or Nth Harmonic Content) and Harmonic Tolerance entered in the settings. In the test screen the user can select individual phases for test as well as three phase tests, either Primary or Secondary side of the transformer.

The Harmonic Shot test is performed by applying 5% above the harmonic restraint pickup value to see if the relay will restrain, and then applying 5% below the harmonic restraint pickup value to see if the relay operates.



Settings that affect the Harmonic Shot test.

- Power transformer, current transformer, and vector group combination settings determine the tap current which will be used to convert the Per Unit value to actual Amperes that is injected into the relay. This will be the fundamental current applied at the start of the test.
- Prefault Level/Time – these values configure the prefault vector that will be injected before any fault vectors.
- Fault Duration – this setting defines the number of ms the fault vector will be applied. Make sure that this value is slightly more than the operating time of the relay to insure that the test set will see the trip contacts pickup.

- Harmonic Content – If this value is not entered correctly in the settings screen, the test routine will be performed incorrectly.
- 1. Connect the appropriate output terminal(s) for the selected channel(s) to be used.
- 2. Connect the desired Binary Input terminal to sense the relay trip contacts. Press the selected Binary Input. If the Binary Input is already set to **Use as Trip (enabled)**, select for the appropriate sensing Normally Open, Normally Closed, Voltage Applied, or Voltage Removed.



Application Note: The Prefault values will be applied prior to applying the harmonic block test. Make sure that all three phase outputs are connected to the relay under test. Set the binary input to sense Normally Open contacts to be Open (Restrain at + 5%) and Close (Trip at – 5%).

- 3. Press or click on the Blue Play  button to run the Harmonic Shot Test. A menu list will be presented to the user to select which winding to test. For the single-phase tests, the test current will be applied on the phase being tested, while zero current will be applied across the other two phases. For the three phase tests, the test set will inject the fault vectors across all 3 phases on the desired Winding (Primary or Secondary).
- 4. To View the test result, press the Add to Reports  button.

### 3.10 Synchronizer Test

The Synchronizer Test is only available for SMRT units, which have the RTMS Enhanced feature enabled. Pressing the Synchronizer test button provides the testing of synchronizing relays. These tests should be conducted in accordance with the manufacturers relay specifications.

Selection of the Synchronizer  button will provide the following Relay Settings and Configuration screen.

### 3.10.1 Synchronizer Relay Settings and Configuration Screen

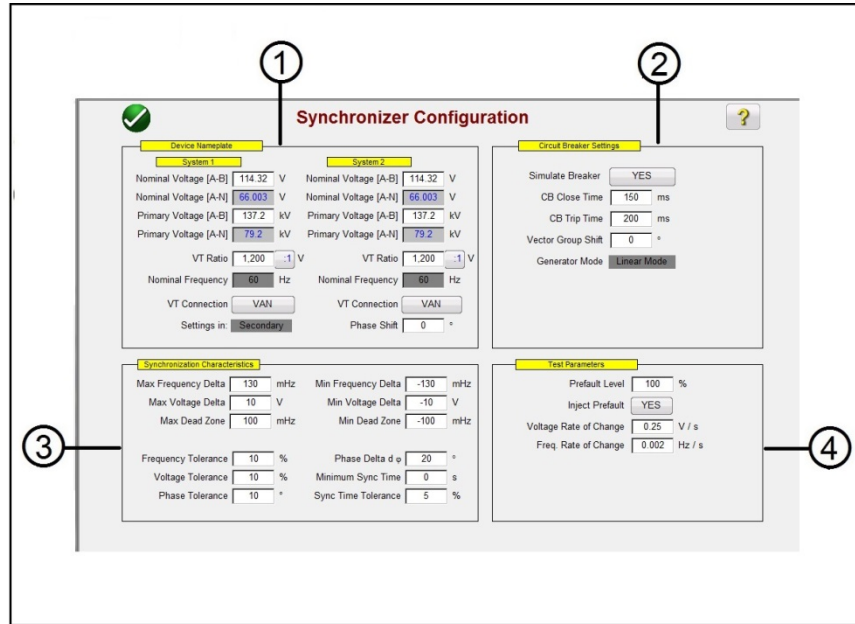

Figure 216 Synchronizing Relay Settings and Configuration Screen

#### 3.10.1.1 ① Device Nameplate – System Settings

The relay test system voltage channels are used to simulate the two systems being synchronized together, as represented as System 1 and System 2. Enter the appropriate System Values in the windows provided. Note that if you enter the primary values and VT Ratios the software will automatically calculate the appropriate secondary voltages to be applied, and vice versa. Pressing or clicking on the VT Connection button will provide a list to select which voltage channels will be applied to the relay under test.

#### 3.10.2 ② Circuit Breaker Settings

Press or click on the Simulate Breaker operation if you need to simulate the circuit breaker Closing or Opening. Enter the appropriate Breaker Close and Trip times in the windows provided. The Generator Mode is set to Linear Mode. The linear mode uses the  $dv/dt$  and  $df/dt$  to control the system outputs.

#### 3.10.3 ③ Synchronization Characteristic Settings

Enter the relay settings into the windows provided. The Max and Min values represent the difference between System 1 reference values and System 2 test values. The Tolerance values are normally based upon the relay's specifications.

3.10.4 ④ Test Parameters

If the relay requires Prefault values to be applied prior to starting the test, press or click on the Inject Prefault button to select yes. As mentioned previously the linear mode uses the  $dv/dt$  and  $df/dt$  to control the system outputs. Based upon the relay settings, enter the appropriate Rate of Change for the V/s and the Hz/s.

3.10.5 **Synchronizer Characteristic Test Selection Screen**

After all the setting values have been entered, press, or click on the Green check button, which will take you to the Test Selection Screen. In the test selection screen, the user may select from three different tests, Quick Test, Dynamic Test, and Point of Origin test, or the user may create their own test lines by pressing or clicking on the test screen first outside and then inside the characteristic.

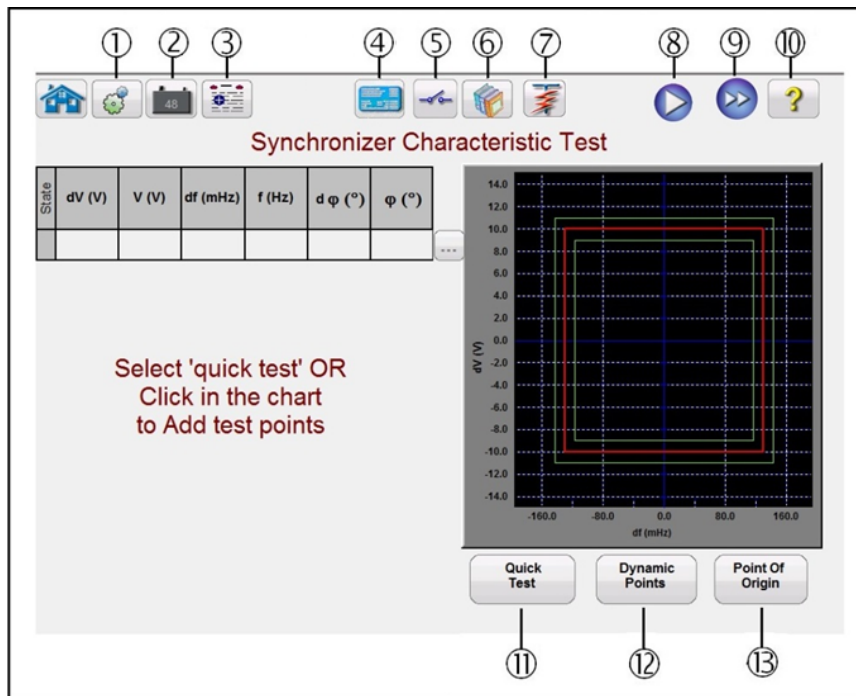



Figure 217 Synchronizer Characteristic Test Selection Screen

3.10.5.1 ① The Configuration button 

Press the button to go to the RTMS Configuration Screen. See Section 2.2.1 Configuration for more information about the Configuration Screen.

3.10.5.2 ② Battery Simulator button 

The Battery Simulator button – Turns the Battery Simulator ON and OFF by pressing the button, the color changes red for ON and black for OFF. The voltage to be applied is displayed in the button and can be changed by pressing the configuration button.

3.10.5.3 ③ Test Report button 

Press this button to review the test results.

3.10.5.4 ④ Return to Synchronizer Relay Settings and Configuration Screen button 

Return to the Synchronizer Characteristic Screen button provides access back to the relay and test settings screen.

3.10.5.5 ⑤ Binary Input Setting button 

Press this box to reveal the Binary Input Dialog box.

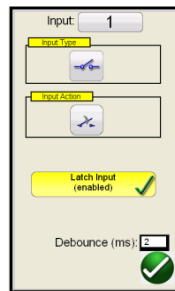

The default settings are Binary Input 1, dry contacts as indicated by the Input Type, and Input Action defaults to show the Closing of the Normally Open contacts. To change the Input Type from dry contacts to Voltage, press the Input Type icon, and it changes to voltage. To change to the opening of Normally Closed contacts press the Input Action icon and it changes to show closed contacts opening. For timing the operating time of the synchronizing element, the timer is defaulted to Latched Input enabled mode, which means the timer will stop on the first contact closure. Note the Debounce time is set to 2 ms.

3.10.5.6 ⑥ Relay Library button 

Pressing the Relay Library will provide a library of relay specific characteristics by various manufacturers.

### 3.10.5.7 ⑦ Predefined Test button

Pressing the predefined test button, the user can select from a list of predefined frequency relay tests that were previously saved to the database.

### 3.10.5.8 ⑧ Run Test button

Pressing or clicking the blue Run Test button will apply the Prefault vector for the specified Time, and then will play all the test lines on the test screen.

### 3.10.5.9 ⑨ Run All Tests button

Pressing the Run All Tests button will provide the user with a list to select which test(s) they desire to run, see the following figure.

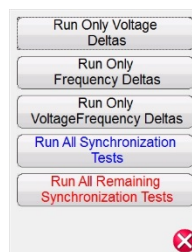

Since some relays only respond to only to  $\Delta f$  frequency change, the user can select to Run Only Frequency deltas. To remove test lines associated with the  $\Delta V$ , press, or click on the Run/Edit  button located next to the test associated with the  $dV$  (V) test and select Delete from the menu. The same is true should the user desire to remove any other test line (s).

### 3.10.5.10 ⑩ Help button

Pressing this button will open the help associated with the Synchronizer test.

### 3.10.5.11 ⑪ Quick Test button

Four test lines will be drawn (two will ramp frequency, and two will ramp voltage). Any test lines can be deleted and redrawn by the user as desired using the Run/Edit  button. Press the Run/Edit button for the individual test line. The user will then be presented with the following option screen.



Figure 218 Run/Edit Button Options

The user can; Edit the Start and End values, Run the selected test individually, Run the Remaining tests, Delete the selected test, or Delete All Tests. Press the red X to exit.

#### 3.10.5.12 Dynamic Points option

The Dynamic Points option provides eight test lines. It is like the Quick Test it provides an additional 4 test lines, one on each corner of the characteristic representing a dynamic ramp of both voltage and frequency.

#### 3.10.5.13 Origin Test Points option

The Origin Test Points option – Similar to the Dynamic Points options with 8 test lines, only the end point is the origin.

### 3.11 Frequency Test

The Frequency Test is only available for SMRT units which have the RTMS Enhanced feature enabled. Pressing the Frequency test button provides the testing of frequency sensing relays. These tests should be conducted in accordance with the manufacturers relay specifications.

Selection of the Frequency  button will provide the following Relay Settings and Configuration screen.

#### 3.11.1 Frequency Relay Settings and Configuration Screen

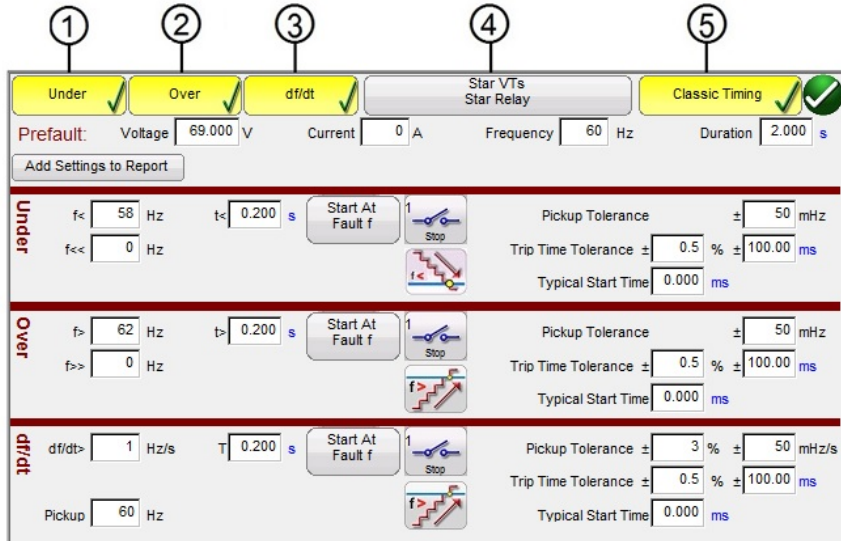

Figure 219 Frequency Relay Test Settings Screen

There are three types of frequency relay test options, Under Frequency, Over Frequency, and df/dt. If your relay is Under frequency only, simply press or click on the Over and df/dt buttons to deselect these settings windows. Press the Add Settings to Report to add the relay and test settings to the final test report. The following are descriptions of each settings window.

### 3.11.1.1 ① Under Frequency Relay Test Settings

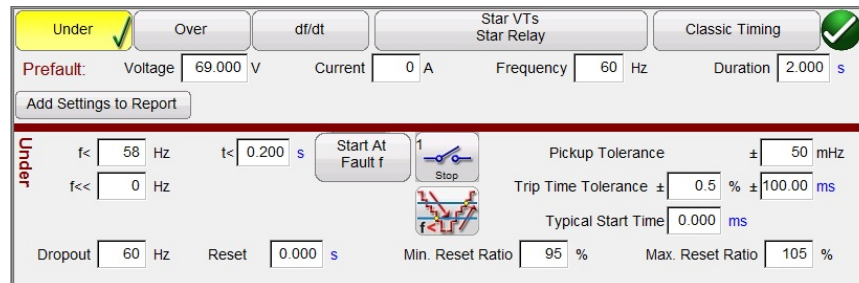

Figure 220 Under Frequency Relay Test Settings

**f<**: Enter the relay under frequency setting value for pickup.

**t<**: Enter the relay trip time setting value in seconds. Click on the s to change to cycles.

**f<<**: Enter the relay under frequency setting value for the fault frequency.

**Start At Fault f**: There are two buttons associated with the Timer Start; **Start Timer At Pickup Frequency** and **Start Time with Binary Input**.

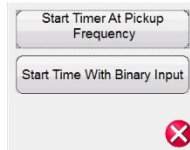



Figure 221 Timer Start At Selection List

Starting the timer at pickup simply means that the timer will start running when the test frequency crosses through the pickup frequency point either as a ramp or as a step function. Starting the timer with binary input simply means the timer will be started from an external contact closing.

**Stop:** Press or click on the binary input  icon to select which binary input will be used to stop the timer and select the Input Type and Input Action associated for the timer stop.

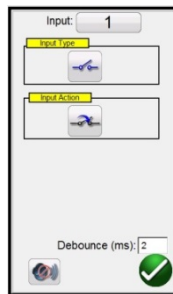



Figure 222 Binary Input Screen

The default settings are Binary Input 1, dry contacts as indicated by the Input Type, and Input Action defaults to show the Closing of the Normally Open contacts. To change the Input Type from dry contacts to Voltage, press the Input Type icon, and it changes to voltage. To change to the opening of Normally Closed contacts press the Input Action icon and it changes to show closed contacts opening. For timing, the timer is defaulted to Latched Input enabled mode, which means the timer will stop on the first contact closure. Note the Debounce time is set to 2 ms.

**Pickup Mode:** Press or click on the Pickup Mode  icon to select the mode of ramping the outputs. There are two modes to select from. The default icon is a single ramp down starting from the prefault frequency towards the fault frequency ( $f \ll$ ). The second selection is a double ramp  down and back up looking for pickup and dropout associated with multi-set point relays.

**Pickup Tolerance:** Enter the pickup tolerance of the relay under test in  $\pm$  mHz.

**Trip Time Tolerance:** Enter the time tolerance of the relay under test. Two entries are available,  $\pm$  % of time setting and  $\pm$  ms. Note: changing the Prefault Duration time to Cycles will change the time tolerance to Cycles.

**Typical Start Time:** This is known time delay value associated with the relay under test. This time value is associated with the relay delay time in detecting the pickup frequency value over one or more cycles, and then deciding to indicate the pickup or trip outputs. Typical values vary from 50 to 200 ms. This value is critical in making Pass/Fail determinations in Timing test results. The user should

consult the relay manufacturer's documentation to know what value of time to enter in the window.  
 Note: changing the Prefault Duration time to Cycles will change the start time to Cycles.

**Reset Ratio:** This is a min and max allowable tolerance associated with the dropout reset setting, which is associated with the double ramp pickup test. The post fault ramp will ramp back to the pre-fault condition, once the relay picks up it is in a trip state. The post fault ramp will be able to detect the relay dropout and record the dropout point. For under frequency relays the dropout will be a value slightly greater than the pickup setting. Check the relay manufacturer's literature to verify reset setting values and % tolerances for appropriate values.

### 3.11.1.2 ② Over Frequency Relay Test Settings

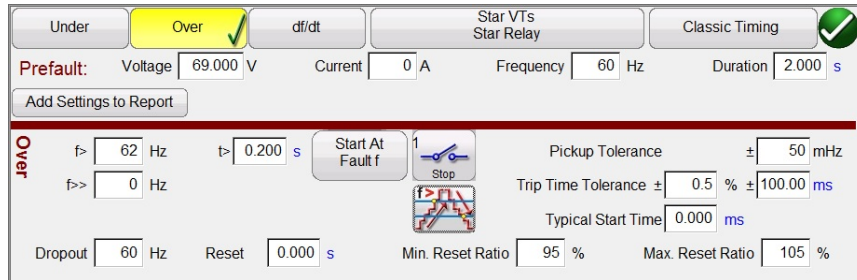

Figure 223 Over Frequency Relay Test Settings

**f>:** Enter the relay over frequency setting value for pickup.

**t>:** Enter the relay trip time setting value in s. Click on the s to change to cycles.

**f>>:** Enter the relay over frequency setting value for the fault frequency.

**Start At Fault f:** There are two buttons associated with the Timer Start; **Start Timer At Pickup Frequency** and **Start Time with Binary Input**.

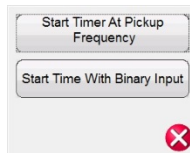



Figure 224 Timer Start At Selection List

Starting the timer at pickup simply means that the timer will start running when the test frequency crosses through the pickup frequency point either as a ramp or as a step function. Starting the timer with binary input simply means the timer will be started from an external contact closing.

**Stop:** Press or click on the binary input  icon to select which binary input will be used to stop the timer and select the Input Type and Input Action associated for the timer stop.

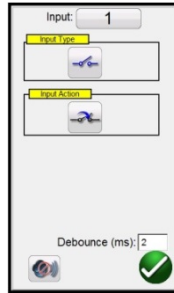



Figure 225 Binary Input Screen

The default settings are Binary Input 1, dry contacts as indicated by the Input Type, and Input Action defaults to show the Closing of the Normally Open contacts. To change the Input Type from dry contacts to Voltage, press the Input Type icon, and it changes to voltage. To change to the opening of Normally Closed contacts press the Input Action icon and it changes to show closed contacts opening. For timing, the timer is defaulted to Latched Input enabled mode, which means the timer will stop on the first contact closure. Note the Debounce time is set to 2 ms.

**Pickup Mode:** Press or click on the Pickup Mode  icon to select the mode of ramping the outputs. There are two modes to select from. The default icon is a single ramp up starting from the prefault frequency towards the fault frequency. The second selection is a double ramp  up and back down looking for pickup and dropout associated with multi-set point relays.

**Pickup Tolerance:** Enter the pickup tolerance of the relay under test in  $\pm$  mHz.

**Trip Time Tolerance:** Enter the time tolerance of the relay under test. Two entries are available,  $\pm$  % of time setting and  $\pm$  ms. Note: changing the Prefault Duration time to Cycles will change the time tolerance to Cycles.

**Typical Start Time:** This is known time delay value associated with the relay under test. This time value is associated with the relay delay time in detecting the pickup frequency value over one or more cycles, and then deciding to indicate the pickup or trip outputs. Typical values vary from 50 to 200 ms. This value is critical in making Pass/Fail determinations in Timing test results. The user should consult the relay manufacturer's documentation to know what value of time to enter in the window. Note: changing the Prefault Duration time to Cycles will change the start time to Cycles.

**Reset Ratio:** This is a min and max allowable tolerance associated with the dropout reset setting, which is associated with the double ramp pickup test. The post fault ramp will ramp back to the pre-fault condition. Once the relay picks up it is in a trip state. The post fault ramp will be able to detect the relay dropout and record the dropout point. For an over frequency relay, the reset ratio will be a value slightly less than the setting, but usually never greater than. Check the relay manufacturer's literature to verify reset setting values and % tolerances for appropriate values.

### 3.11.1.3 ③ df/dt ROCOF Relay Test Settings

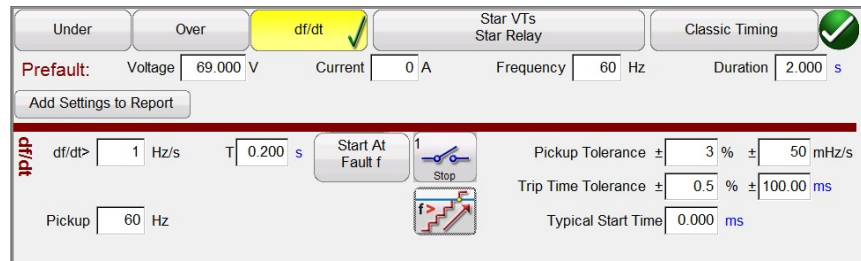



Figure 226 df/dt Test Setting screen.

**df/dt >:** The rate of change is defined as the df/dt setting in Hz/s. Enter the relay Hz/s setting here. The change in frequency happens when the frequency passes through the positive going zero-crossing of the voltage output waveform. The test limits the df/dt setting to a maximum value of

10Hz/sec. The test defaults to ramping the frequency up. Press on the frequency ramp button



to change to  ramp frequency down. Note: The sign of the Hz/s changes from a positive number to a negative number.

The frequency increment is calculated for each delay period prior to starting the dynamic ramp. The first step is defined by the pre-fault values, which are necessary to energize the relay before the fault condition. If we use a df/dt of -1 Hz/s and want to ramp from 60 to 50 Hz, then the time would be 10 s to go from 60 Hz to 50 Hz.

**T (Trip Time):** Enter the trip time setting from the relay in s. Clicking on the s will change the time to CY for Cycles. Note: Changing the Duration setting from s to Cycles will automatically change this setting.

**Pickup:** Enter the Pickup setting value of the relay here. The pickup point indicates the frequency when the relay first detects the fault. Once the pickup point is reached the relay starts its timer and will trip.

**Start Time At:** There are two buttons associated with the Timer Start; **Start Timer At Pickup Frequency** and **Start Time with Binary Input**. Starting the timer at pickup simply means that the timer will start running when the test frequency crosses through the pickup frequency point either as a ramp or as a step function. Starting the timer with binary input simply means the timer will be started from an external contact closing.

**Stop:** Press or click on the binary input  icon to select which binary input will be used to stop the timer and select the Input Type and Input Action associated for the timer stop.

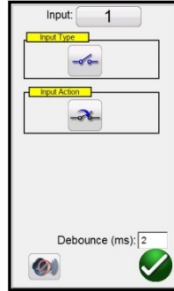

Figure 227 Binary Input Screen

The default settings are Binary Input 1, dry contacts as indicated by the Input Type, and Input Action defaults to show the Closing of the Normally Open contacts. To change the Input Type from dry contacts to Voltage, press the Input Type icon, and it changes to voltage. To change to the opening of Normally Closed contacts press the Input Action icon and it changes to show closed contacts opening. For timing, the timer is defaulted to Latched Input enabled mode, which means the timer will stop on the first contact closure. Note the Debounce time is set to 2 ms.

**Pickup Tolerance:** Enter the pickup tolerance of the relay under test. Two entries are available,  $\pm$  % of pickup setting and  $\pm$  mHz.

**Trip Time Tolerance:** Enter the time tolerance of the relay under test. Two entries are available,  $\pm$  % of time setting and  $\pm$  ms.

**Typical Start Time:** This is known time delay value associated with the relay under test. This time value is associated with the relay delay time in detecting the pickup frequency value over one or more cycles, and then deciding to indicate the pickup or trip outputs. Typical values vary from 50 to 200 ms. This value is critical in making Pass/Fail determinations in Timing test results. The user should consult the relay manufacturers' documentation to know what value of time to enter in the window.

#### 3.11.1.4 ④ VT and Relay Connections

Press or click on this button to access the Selection Type menu for the VT and Relay connections.

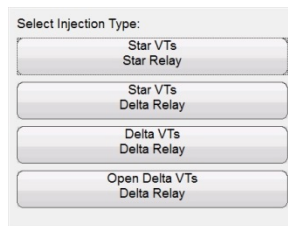

Figure 228 Select Injection Type Menu

#### 3.11.1.5 Classic Timing Test Selection

Press or click on the Classic Timing test button to perform a step timing test where the output frequency is step changed from the prefault to the fault value. If Classic Timing is not enabled, then

the timing test will be performed by ramping the frequency from the predefault value to the fault value at a pre-calculated ramp rate starting the timer at the Fault Frequency and stopping the timer upon relay trip contact sensing.

### 3.11.1.6 Prefault Settings

The Prefault Values will be the values applied to the relay for the specified Duration time. Duration time defaults to s for seconds. Click on the **s** to change it to **CY** for Cycles. Note that changing the duration time to Cycles also changes the Trip Time Tolerance and Typical Start Time to Cycles. It is necessary to apply the predefault values long enough to allow the relay to reach a state of equilibrium. For example, an electromechanical relay may require several s to allow the induction disk to rotate to a balanced state.

### 3.11.2 Frequency Relay Test Screen

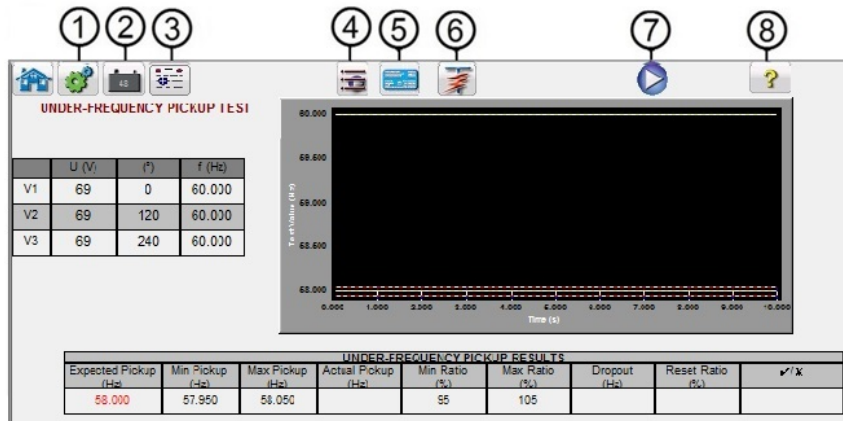

Figure 229 Frequency Relay Test Screen

#### 3.11.2.1 ① The Configuration button



Press the button to go to the Configuration Screen. See Section 2.2.1 Configuration for more information about the Configuration Screen.

#### 3.11.2.2 ② Battery Simulator button



The Battery Simulator button – Turns the Battery Simulator ON and OFF by pressing the button, the color changes red for ON and black for OFF. The voltage to be applied is displayed in the button and can be changed by pressing the configuration button.

#### 3.11.2.3 ③ Test Report button



Press or click on this button to review the test results.

3.11.2.4 ④ Test List button 

Press or click on this button to View the available tests, i.e., Pickup or Timing.

3.11.2.5 ⑤ Return to Frequency Relay Test Settings Screen button 

Return to the Frequency Relay Test Settings Screen button provides access back to the relay and test settings screen.

3.11.2.6 ⑥ Run Predefined Test button 

Pressing the run predefined test button, the user can select from a list of predefined frequency relay tests that were previously saved to the database.

3.11.2.7 ⑦ Run Test button 

Pressing or clicking the blue Run Test button will apply the Prefault vector for the specified Time, and then will play the selected test.

3.11.2.8 ⑧ Help button 

Pressing this button will open the help associated with the Frequency test.

3.11.3 Frequency Relay Pickup Test Screen

The Frequency Pickup test screen will display the Prefault Frequency starting values, the frequency ramp down or up, and the pickup point (green is Pass, red colored dot is Fail), see the following example Under Frequency test result. The injection table on the left hand side of the screen shows the actual fault frequency being applied during test; this is applicable for all tests.

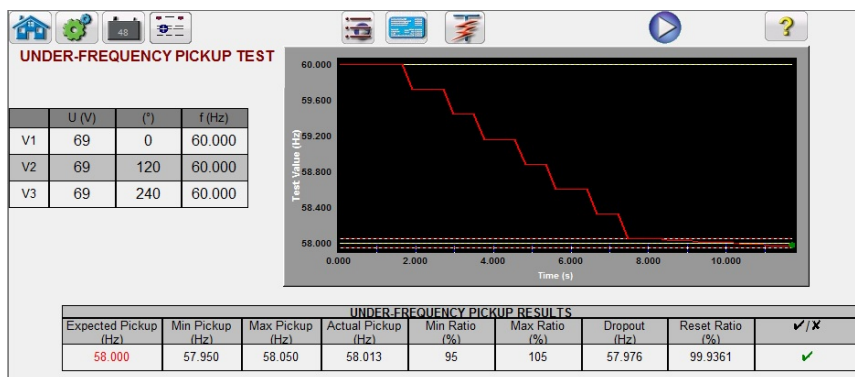

Figure 230 Under Frequency Relay Pickup Test Result

### 3.11.4 Frequency Relay Timing Test Screen

There are two types of Timing Test available to choose from. To do a Classic Timing test, press or click on the Classic button. The Classic test is a step test from the Prefault to a value slightly greater or less than the specified pickup value. The default Timing test is a ramp to fault frequency simulating an actual under or over frequency condition. The ramp starts at the Prefault frequency setting and then ramps up or down until a value slightly greater than or less than the Fault Frequency setting depending on the type of relay selected. Once the Fault frequency value threshold is crossed the relay timing starts. When the relay trips the timer stops. The user will see the Prefault duration, the duration of time associated with the ramping of the output frequency to the Fault frequency value, plus the operating time of the relay, see the following example for an Over Frequency Timing test.

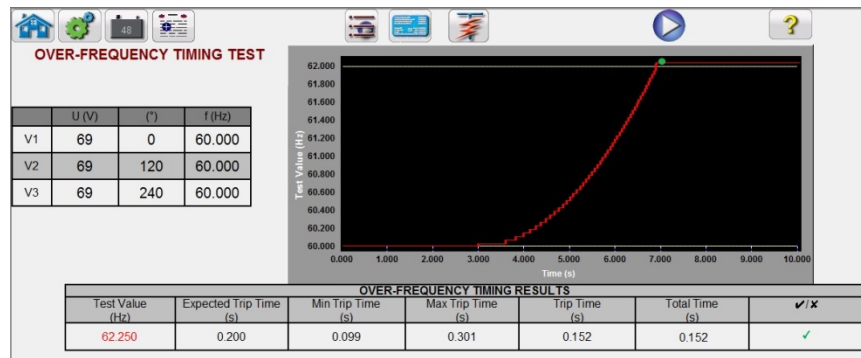



Figure 231 Over Frequency Timing Test

### 3.12 COMTRADE Playback

The COMTRADE Playback is only available for SMRT units, which have the RTMS Enhanced feature enabled. Pressing the COMTRADE test button provides the capability of playing back transient waveform data from the SMRT relay test systems. In other words, it can recreate a fault (waveforms...) recorded by a Digital Fault Recorder, protective relays, or a simulated fault using software tools like the EMTP/ATP programs.

Selection of the COMTRADE  button will provide the following COMTRADE dialog box.

#### 3.12.1 COMTRADE Dialog Box



Figure 232 COMTRADE Dialog Box

From this dialog box a user can convert digital fault recorder data in COMTRADE format to hexadecimal files compatible with SMRT waveform generators, select the channels and ranges to be uploaded to SMRT unit, and upload and output the waveforms.

#### 3.12.1.1 Processing a COMTRADE File

The IEEE Power System Relaying Committee has established a standard called COMTRADE (common transient data exchange) see IEEE C37.111. In addition, the IEC has also adopted the standard as IEC 60255-24. The RTMS COMTRADE test feature uses the COMTRADE data either in the ASCII or Binary formats.

Processing a Configuration file involves the process of converting the data in COMTRADE ASCII or Binary format to SMRT-ready hexadecimal format.

Prior to creating a test, the COMTRADE .cfg and .dat files need to be placed into a file folder on your PC or in the . The .cfg and .dat file must be in the same directory and have the same name prior to the file extension.

From the COMTRADE dialog box, click on the  COMTRADE File button. The windows file navigator window will appear. Navigate to the Waveforms folder. Use this dialog box to select a COMTRADE configuration file and to convert the COMTRADE data to hexadecimal data.

#### 3.12.2 COMTRADE Test Screen

When the file is selected, the program will automatically grab the first three channels of voltage and current and display the values in either primary or secondary values, depending on the ratios provided in the Configuration file (primary or secondary).

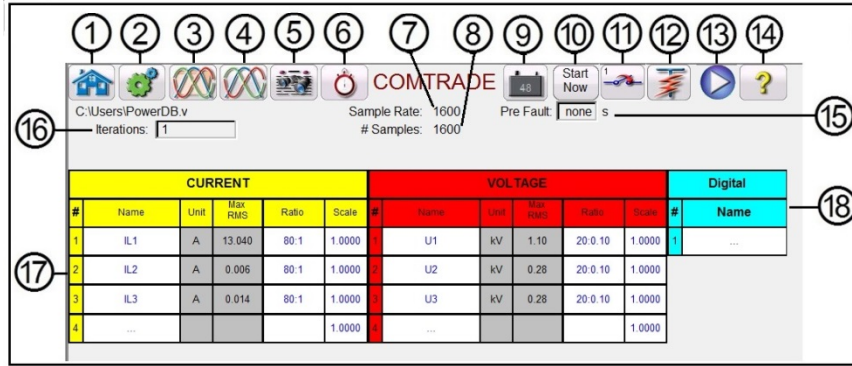



Figure 233 Example COMTRADE Playback Test Screen

The following is a brief description of the buttons and fields available in the COMTRADE test screen dialog box.

3.12.2.1 ① The Home button 

Pressing the Home icon will return you to the manual test screen.

3.12.2.2 ② Configuration Screen button 

Press the button to go to the Configuration Screen. See Section 2.2.1 Configuration for more information about the Configuration Screen.

3.12.2.3 ③ Open COMTRADE File button 

Press the Open COMTRADE File button to go to the Waveform subdirectory to select a COMTRADE file.

3.12.2.4 ④ COMTRADE Waveform View button 

Press the COMTRADE Waveform View button to preview the COMTRADE waveform and make any additional adjustments before downloading and playing the waveforms. It is recommended to view the waveform before applying predefault values.

3.12.2.5 ⑤ Report Options button 

Once the test is completed, press Report Options button. This button will add the present test result to the report. It also displays the report and allows the user to name the test, enter limits, comments, or deficiencies. Reports can be saved to the STVI internal memory and transferred to PowerDB via a USB memory stick. Previous tests results can be loaded, and the 'Retest' option can be used to repeat the test using the same parameters as the previous test.

3.12.2.6 Ⓒ Configure Timer button 

Press the **Configure Timer** button to view the **Timer Setup** screen and Labels. The user can view and set where each timer starts and stops (see the following figure).



#	Timer Name	Min. (sec.)	Max. (sec.)	Value (sec.)	Start Condition	Stop Condition
1	Timer 1	0.000	0.000	0.000	On Play	Post 1
2	Timer 2	0.000	0.000	0.000		
3	Timer 3	0.000	0.000	0.000		
4	Timer 4	0.000	0.000	0.000		
5	Timer 5	0.000	0.000	0.000		
6	Timer 6	0.000	0.000	0.000		
7	Timer 7	0.000	0.000	0.000		
8	Timer 8	0.000	0.000	0.000		
9	Timer 9	0.000	0.000	0.000		
10	Timer 10	0.000	0.000	0.000		

Figure 234 Sequence Timers Settings and Labels Screen

Timer Start options provide the starting of multiple timers associated with a change of state on a timer post, Start on the beginning of Playback, start the position of the cursor on the waveform, start on trigger (normally associated with end-to-end test).



Figure 235 COMTRADE Timer Start Options

Timer Stop options provide selective timer stopping of multiple timers with a change of state on a timer post, or at the end of the test.



Figure 236 COMTRADE Timer Stop Options

3.12.2.7 ⑦ Sample Rate

The Sample Rate indicates the Sample Rate of the recorded data. The sample rate is taken from the configuration (.cfg) file. If no sample rate is shown in the configuration file (some relay COMTRADE files are missing the sample rate), RTMS will calculate it from the data file.

3.12.2.8 ⑧ # Samples

# Samples is the number of samples in the data (.dat) file.

3.12.2.9 ⑨ Battery Simulator button



The Battery Simulator button – Turns the Battery Simulator ON and OFF by pressing the button, the color changes red for ON and black for OFF. The voltage to be applied is displayed in the button and can be changed by pressing the configuration button.

3.12.2.10 ⑩ Start Now button.

Start Now button works in conjunction with the blue Run Test button.



Figure 237 COMTRADE Start Now Options

Clicking or pressing the Start Now button will open a menu so that the user can select if they want the test to start upon pressing or clicking on the Blue Run Test button, or a Contact change of state. There are two IRIG-B Start options (**requires the IRIG button is enabled in the Configuration screen**). The first option is to start upon a specific time as provided by the IRIG-B decoded time on binary input #1 (used for end-to-end tests). The second option is to start upon decoding the IRIG-B + a Delay time. The delay time is associated with the delay of other manufactures relay test systems that are slower than the SMRT systems. Selecting the Start IRIG button, upon pressing or clicking on the Blue Run Test button a window will appear showing the current UTC time decoded with the preset

trigger time 1 minute into the future. Pressing or clicking on the green check button will set the trigger time as displayed.

#### 3.12.2.11 ⑪ Binary Input Setting button

Press this button to reveal the Binary Input Dialog box.

#### 3.12.2.12 ⑫ Run Predefined Test button

Pressing the run predefined test button, the user can select from a list of predefined relay tests that were previously saved to the database.

#### 3.12.2.13 ⑬ Run Test button

Pressing or clicking the blue Run Test button will download the waveforms, and based upon the Start Now Setting, the test set will apply the prefaul vector, then step to the COMTRADE playback values and look for the relay under test to operate.

#### 3.12.2.14 ⑭ Help button

Pressing this button will open the help associated with the COMTRADE test, as well as reset the system.

#### 3.12.2.15 ⑮ Pre Fault time window

This allows the operator to “add” additional prefaul cycles to the original fault record (needed for proper polarization of the relay). Pre Fault time defaults to **s**, seconds. Press or click on the **s** and it will change to **Cy** Cycles. When a prefaul is selected, two additional fields appear. One for voltage and one for current. **Match** is the default setting, which means the prefaul values of voltage and current will *match* the prefaul values in the configuration/data files at the beginning of the recorded waveform. It is advisable that this be done after inspecting the waveform since it is possible that 0 values are at the start of the waveform. If the user does not wish to match the beginning of the waveform, then they can select **Enter Amplitude**, where the user can enter their own desired prefaul values of voltages and currents. The values entered are peak values, because that is what is in the data files according to the standard. If the user wants to have RMS values, then they will need to multiply by 0.707.



**NOTE:** The number of cycles required for polarization varies. It is recommended that a minimum of 30 Cycles of prefaul be added to the COMTRADE recording. Contact your relay manufacturer technical support or review your relay manual for recommended prefaul time settings.

#### 3.12.2.16 ⑯ Iterations window

The default value is “1”. Upon pressing or clicking on the Blue Run Test button the test will be executed one time. If you desire to cycle the relay through several iterations of the same fault, enter the desired number of iterative cycles as an integer number.

### 3.12.2.17 ⑰ Analog Voltage and Current Values

The software will display the first three analog channels as defined by the Configuration file. To select other channels, simply click or press on the name window provided and a list of available channels will be provided to select from. If your test system has more than three current channels, to select more channels simply click in the “blank” channel and select the next analog channel. Continue this selection process until all the desired channels are selected.

### 3.12.2.18 ⑱ Digital Channels

The digital channel **Name** defaults to blank. To playback digital channels, click on the window provided and the names of all the digital channels will be provided.

## 3.12.3 Processing the COMTRADE File

The analog values shown may be in Primary or Secondary Values as defined by the Configuration file. The PT and CT ratios are either automatically provided, or entered by the user, depending on the year of the COMTRADE standard file format. Files that follow the 1999 standard and later should have PT and CT ratios in the configuration (.cfg) file. However, not all manufacturers strictly follow the standard, and these ratios may be missing. If they are missing, and the data (.dat) file is in primary values, the user can manually enter PT and CT ratios to convert the primary to secondary values for the test set to play, see the following example.

The screenshot shows the COMTRADE software interface. At the top, there is a toolbar with icons for home, settings, waveform, data, and help. Below the toolbar, the file path is C:\Users\Documents\PowerDB. The Sample Rate is 14400 and the # Samples is 2948. The Pre Fault is set to none. The Iterations are set to 1. The main table is divided into three sections: CURRENT (yellow header), VOLTAGE (red header), and Digital (cyan header). The CURRENT section has columns for #, Name, Unit, Max RMS, Ratio, and Scale. The VOLTAGE section has columns for #, Name, Unit, Max RMS, Ratio, and Scale. The Digital section has columns for # and Name. The table contains data for three channels: KINGA, KINGB, and KINGC. The Ratio column for all channels is 800:1. The Scale column for all channels is 1.0000. The Max RMS values are 13.609 for KINGA, 0.765 for KINGB, and 1.158 for KINGC. The Max RMS values for VOLTAGE are 99.70 for KINGA, 106.81 for KINGB, and 110.45 for KINGC. The Digital section is currently blank.

CURRENT						VOLTAGE						Digital		
#	Name	Unit	Max RMS	Ratio	Scale	#	Name	Unit	Max RMS	Ratio	Scale	#	Name	
1	KINGA	NODEA	A	13.609	800:1	1.0000	1	KINGA	V	99.70	2000:1	1.0000	1	...
2	KINGB	NODEB	A	0.765	800:1	1.0000	2	KINGB	V	106.81	2000:1	1.0000		
3	KINGC	NODEC	A	1.158	800:1	1.0000	3	KINGC	V	110.45	2000:1	1.0000		
4	...				1.0000	4	...				1.0000			

Figure 238 Locating Primary to Secondary Ratios in the Test Screen

To change a ratio, simply click in or press any ratio window provided and enter the ratio.

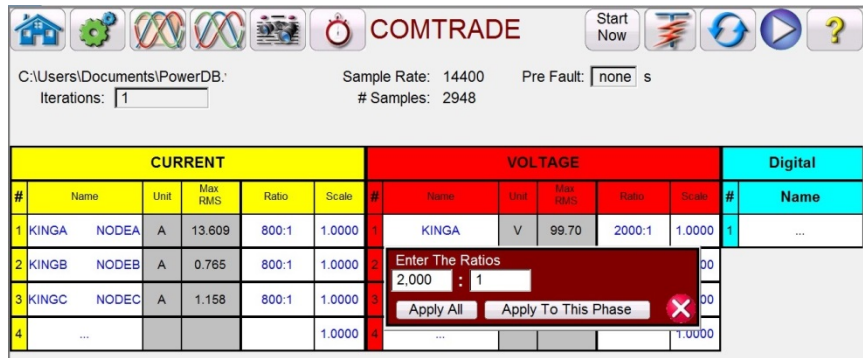

Figure 239 Changing Ratios Dialog Box

The software will ask if you want to **Apply All** or **Apply To This Phase** only. Upon pressing the appropriate application button, you will see the Maximum RMS voltage and/or current that will be applied during the test.



Also, take careful note of the Unit values, as some channels may be recorded in Primary and some in Secondary units. Sometimes the test currents will exceed the maximum of 32 A per phase. The SMRT amplifiers can output fault currents of up to 60 A for 1.5 s or 90 cycles. Since most faults last less than a few cycles this will not be an issue upon playback. Test currents above 60 A are not allowed.

The primary use of the **Scale** is to adjust voltage and current channels proportionately together, so as not to change the “impedance” that a distance relay would “see.” For example, after adjusting the outputs by entering the CT/PT ratios, let us assume that one output current shows 70 A and the fault voltage is 30 V. Since the current channels cannot playback more than 60 A, the current values need to be adjusted down to 60 A. Therefore, by adjusting the Scale to 0.8570 the user may lower the current to say 59.99 A. The user will need to lower all other outputs proportionately, thus reducing the fault voltage to 25.71 V.

### 3.12.3.1 Adding Digital channel playback.

To playback digital channels, click on the window provided and the names of all the digital channels will be provided.

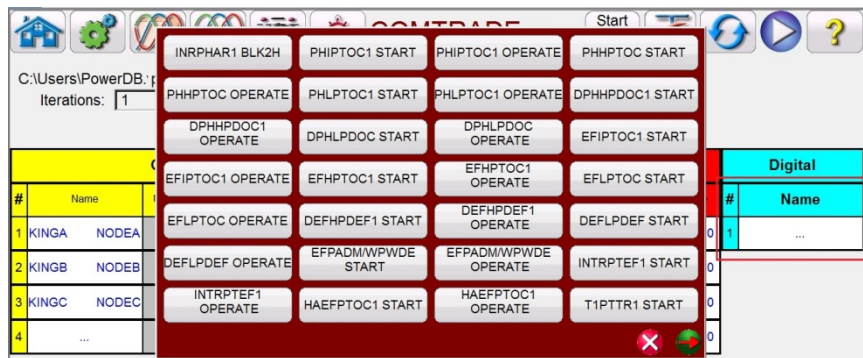

Figure 240 Selecting Digital Channels for Playback

Click on the desired digital channels, which will be associated with the appropriate Binary Output channel, see the following example.

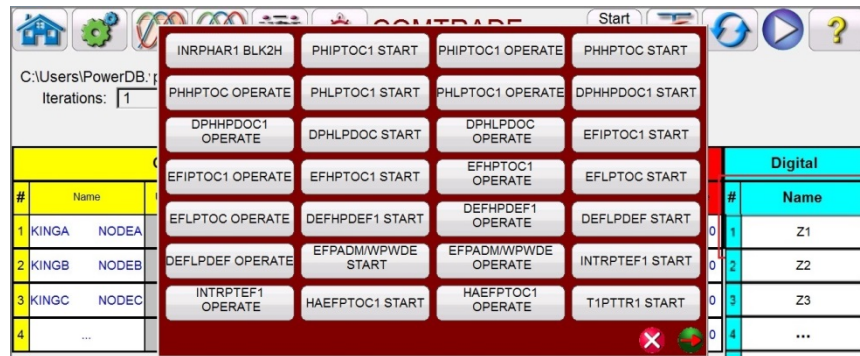



Figure 241 Assigning Three Digital Channels for Playback

Once all the appropriate channels have been selected, with proper ratios set, and scaling completed you have completed the creation of a test.

### 3.12.3.2 Viewing COMTRADE Playback Waveforms

To view the waveforms that will be played back press or click on waveform  button, see the following example.

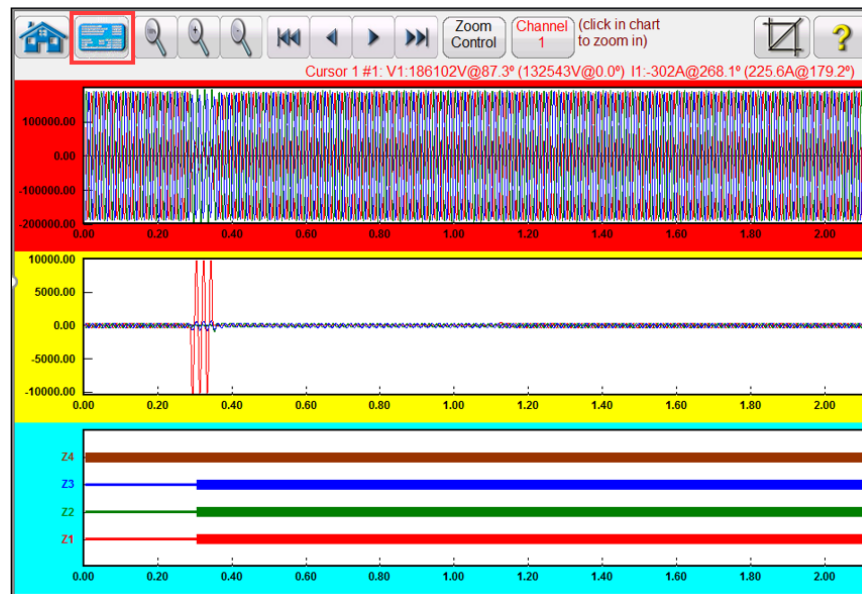

Figure 242 Viewing Analog and Digital Channels for Playback

The press the blue Relay Settings button (highlighted in red above) to return to the previous screen.

### 3.12.3.2.1 Zoom and Cursor Controls

Use the Zoom in and out buttons to zoom on the waveforms. The forward and backwards buttons will move the waveform along the time axis so that the user can view the whole waveform while zoomed in. If a cursor is selected, the forward and backward arrows will move the cursor. The Zoom Control button (highlighted in red) will toggle between zoom functions, and cursor selection, see the following example.

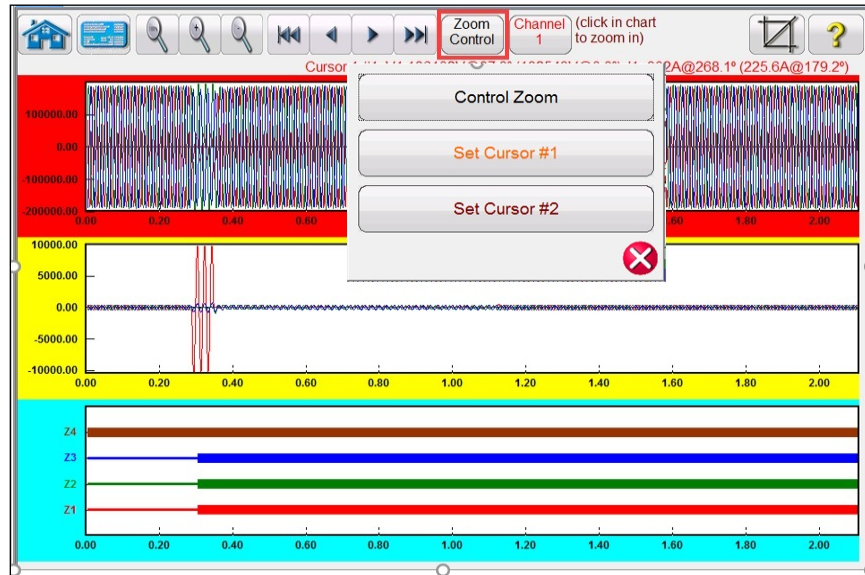

Figure 243 Selection of Zoom Control

The cursor selected shows the values of the channels selected above the window. The format is as follows:

Cursor #, Sample #, Channel Selected, RMS Magnitude, RMS Angle, (Peak Magnitude, Phase Angle), Current Channel Selected, RMS Magnitude, RMS Angle, (Peak Magnitude, Phase Angle), Cursor to Cursor difference time in ms.

The text is color-coded and will change depending on which phase is selected see the following example.

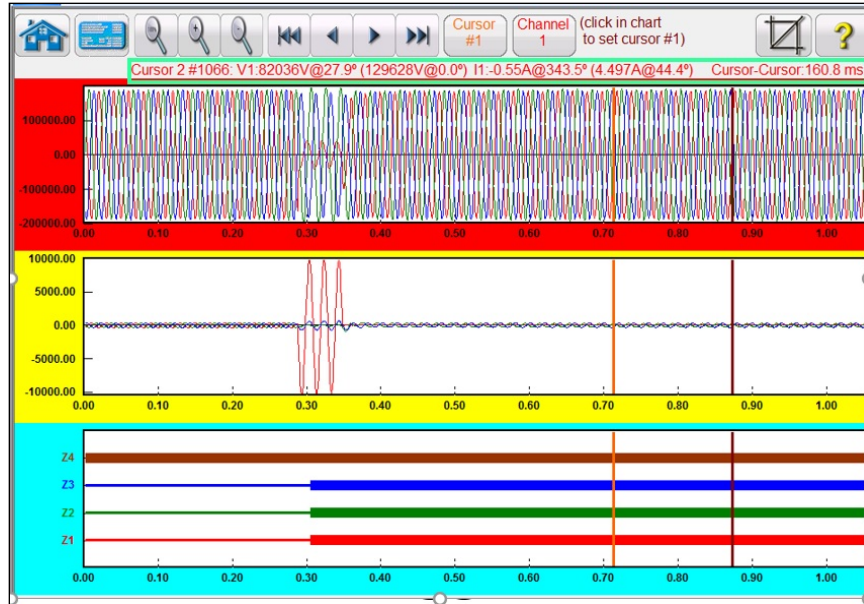



Figure 244 Using Cursors

### 3.12.3.2.2 Cropping button

The second to last button in the top row is the cropping  button. This will let you crop a waveform to what is between the cursors. If you press the Run Test button, it will only play back what is between the two cursors. To remove the crop, press the crop button again.

### 3.12.3.3 Saving Test

To save the test click or press on the FILE tab and save as a PowerDB Test Template. When you want to run the test, with the test set powered up and ready, simply open the test template, and press the Blue Run Test button.

## 3.13 Power Swing and Out of Step Simulator

Press or click on the Power Swing  button to access the Power Swing input-setting screen see the following figure.

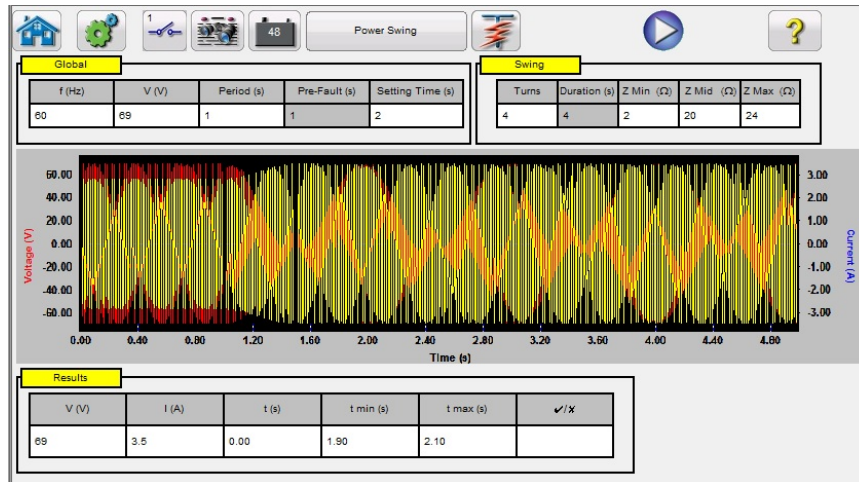

Figure 245 Power Swing Input Setting Screen

The Power Swing simulation tool is like the Power Swing tool in the Fault Calculator, which uses two superimposing waveforms of similar frequencies to provide a smooth impedance ramp. This method is like a two-source model in that both sources have similar frequencies and amplitudes. For details regarding the theory and some equations associated with the Power Swing simulation, see section. 3.1.19.1.6 Power Swing.

### 3.13.1 Power Swing Test Screen

The following is a brief description of the buttons and fields available in the Power Swing test screen dialog box.

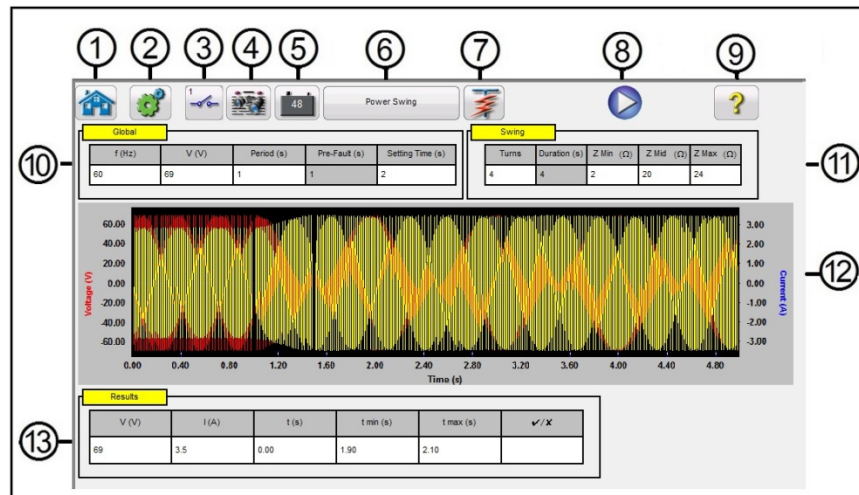

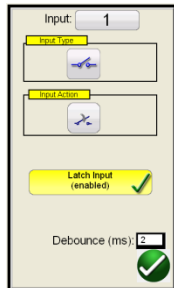

Figure 246 Example Power Swing Test Screen

1. Pressing the home  icon will return you to the manual test screen.

2. Press the Configuration  button to go to the RTMS Configuration Screen.

3. Press the Binary Input Setting button  to reveal the Binary Input Dialog box.





The default settings are Binary Input 1, dry contacts as indicated by the Input Type, and Input Action defaults to show the Closing of the Normally Open contacts. To change the Input Type from dry contacts to Voltage, press the Input Type icon, and it changes to voltage. To change to the opening of Normally Closed contacts press the Input Action icon and it changes to show closed contacts opening. For timing the operating time of the relay power swing element, the timer is defaulted to Latched Input enabled mode, which means the timer will stop on the first contact closure. Note the Debounce time is set to 2 ms.

4. Once the test is completed, press Add/Review Test Report  button. This button will add the present test result to the report. It also displays the report and allows the user to name the test, enter limits, comments, or deficiencies. Reports can be saved to the STVI internal memory and transferred to PowerDB via a USB memory stick. Previous tests results can be loaded, and the 'Retest' option can be used to repeat the test using the same parameters as the previous test.

5. Battery Simulator button . The Battery Simulator button turns the Battery Simulator ON and OFF. By pressing or clicking on the button, the color changes red for ON and grey for OFF. The voltage applied is displayed in the button and can be changed by pressing the configuration button.

6. The Power Swing button  changes to **Out of Step** when pressed or clicked on. This changes the test-setting screen by removing the Mid Z Ohm setting for performing Out of Step tests.

7. Predefined Test button . Pressing the predefined test button, the user can select from a list of predefined Power Swing or Out of Step relay tests that were previously saved to the database.

8. Blue Play  button - Pressing or clicking the blue Run Test button will apply the predefault vector, then step to the Power Swing values and look for the relay under test to operate.

9. Help  button.

10. **Global** window – Global Settings can affect setting values in the Swing and Results windows. The following are descriptions of each setting in the Global window.

**Frequency (Hz):** Nominal System Frequency in Hertz.

**Voltage:** Nominal Line to Ground System Secondary Voltage (V)

**Period:** Time Period of one complete power swing in seconds (s) This setting will be used to calculate the Global **Pre-Fault** time in s, as well as the **Duration** time in seconds in the Swing Window.

**Setting Time:** This is the operating time of the relay in s. This setting will be used in the Results window to set the default Min and Max time evaluation values ( $\pm 5\%$ ). Note that the Min and Max values can be manually changed in the Results window.

11. **Swing** window – Settings in the Swing window are associated with the Impedance Locus. The following are descriptions of each setting in the Swing window.

**Turns:** The number of times that the power swing will repeat around Zmid and Zmin.

**Zmin:** The minimum of the impedance locus ( $\Omega$ )

**Zmid:** This is the second maximum impedance during the power swing ( $\Omega$ )

**Zmax:** This is the starting impedance of the power swing ( $\Omega$ ).



**Application Note:** Make sure that the Zmax is set greater than the power swing blinder setting by at least  $1 \Omega$ . Setting Zmax to a large ohmic value can result with an unrealistic impedance locus approaching the relay impedance-operating characteristic at an undesirable angle. Starting the Zmax just outside of the power swing blinder element works best for this test application.

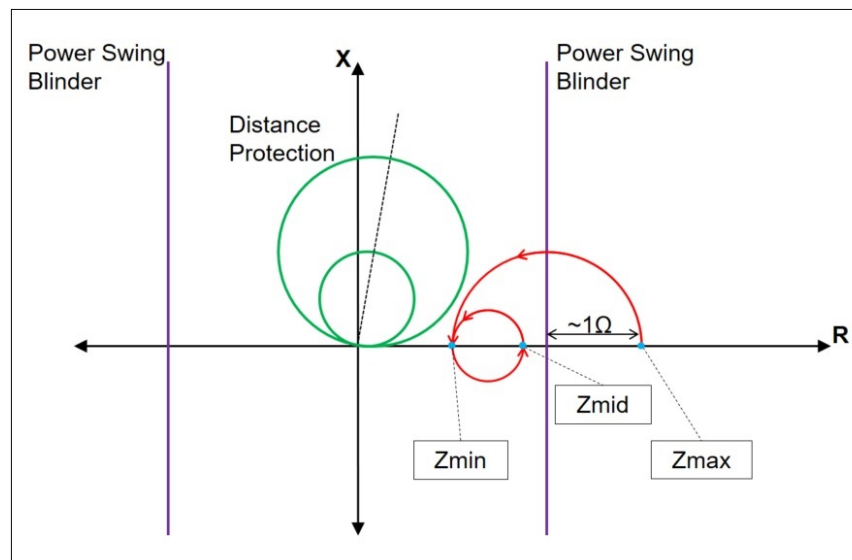

Figure 247 Power Swing Locus

When you press the Run Test button, the test will start with a pre-fault value for the Pre-Fault setting. After the pre-fault time is over, the power swing will begin. If there is only one turn defined, the power swing will begin at the point Zmax and proceed smoothly to Zmin. Once the impedance locus reaches Zmin, it will then continue to Zmid, and the test will end. For tests that have more than one turn, the impedance locus will then continue from Zmid and proceed to Zmin, and then back again to Zmid. This will continue based on the number of Turns setting.

Zmid can be set equal to Zmax if one loop is desired. Zmin cannot be equal to Zmid or Zmax.

12. **Power Swing Waveform:** The Graphic window displays the power swing waveforms that will be played. If more than 1 Turn is specified, the display will include each turn.

13. **Results Window:** The Results window includes the Nominal voltage, the calculated test Current, the operating Time in s, the calculated Min and Max time values in s, and Pass/Fail based upon the recorded operating Time.

### 3.14 SS1 File Playback

SS1 File Playback is used for importing State-Sequence Files (SS1) from ASPEN and CAPE power system simulation software programs. By modeling the power system using ASPEN or CAPE, the relay

can be evaluated dynamically using realistic system test scenarios. Click on the **SS1**  button to open the windows file navigator window. Navigate to the SS1 folder (requires user to create the SS1 file folder and place the SS1 files in the folder). Use this dialog box to select an SS1 file. RTMS will read the SS1 file and create a dynamic state-sequence playback file using the Sequencer Test feature.

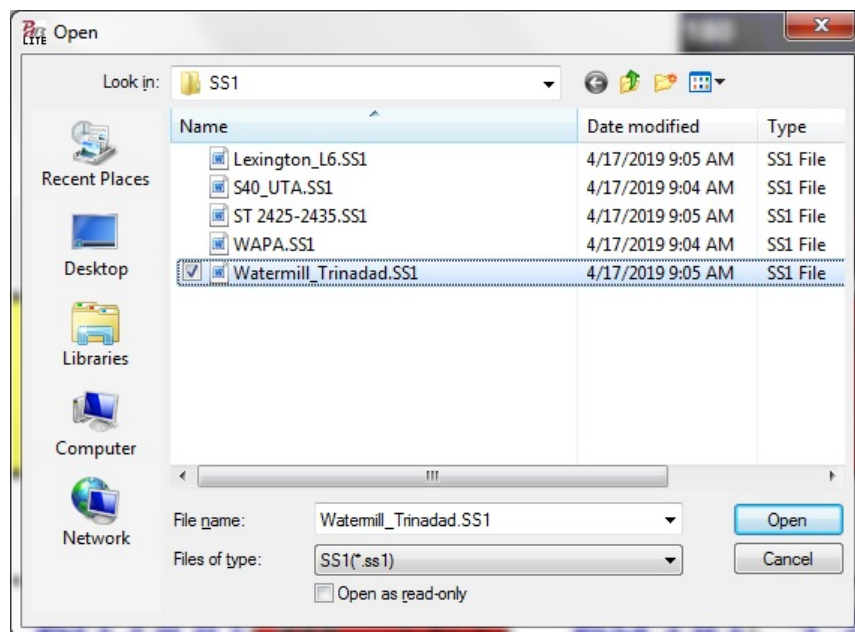

Figure 248 SS1 File Selection Navigator Window

#### 3.14.1 SS1 File Pre-Test Dialog Window

The pre-test dialog window provides the user with several selections on how to start the test, and what type of test report is desired. The following is the SS1 Pre-Test Dialog Box.



Figure 249 Example SS1 File Pre-Test Dialog Box

Using the SS1 file data, RTMS will automatically create a State Sequence Test. Test current, voltages, phase angles, and wait times defined in the SS1 file will appear in the Sequencer Test Screen. There are three Modes to select from, Run Immediately, Wait on IRIG-B (**requires the IRIG button is enabled in the Configuration screen**), and Wait Contact. The Short Report button will only report the prefault and trip times. If unchecked the test report will include all the prefault, and fault test data, wait times, trip times, etc. For End-To-End test, the Short Report preferred.

### 3.14.1.1 Run Immediately button.

RTMS defaults to the Run Immediately mode. All SS1 sequence tests run in the Sequencer test screen. Upon clicking or pressing the green check button, the Run/Edit Test Selection screen appears.

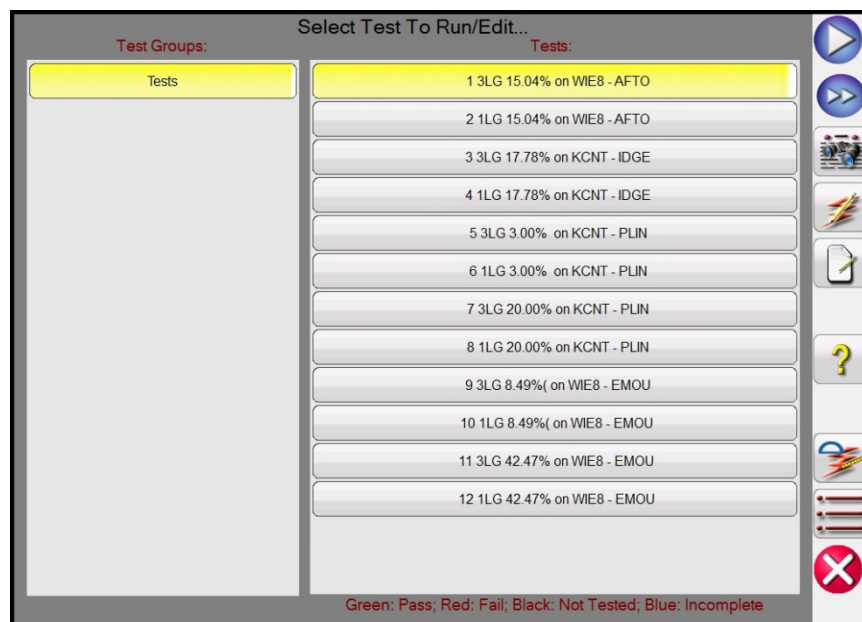



Figure 250 Example Run/Edit Test Selection Screen

As shown in the above figure, there is one Test Group, tests required are listed in the right half of the screen for that group. The following are descriptions for the tools.

- 3.14.1.1.1 Run Test button  Press the Run Test button the select and execute any individual test.

3.14.1.1.2 Run All button  Pressing the run all button the user will see the following options.

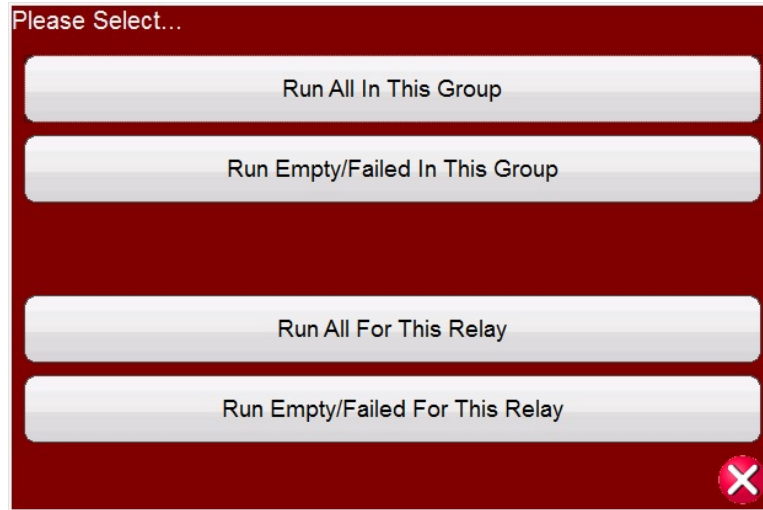



Figure 251 Predefined Run All Options

3.14.1.1.3 View Results button 

Press the Report Options button to view the test report.

3.14.1.1.4 Go To Test Screen button 

Press the Go To Test Screen button to go to the selected test in the Sequencer test screen.

3.14.1.1.5 View/Edit Notes button 

Press the View Edit Notes button to view the test notes or to add notes.

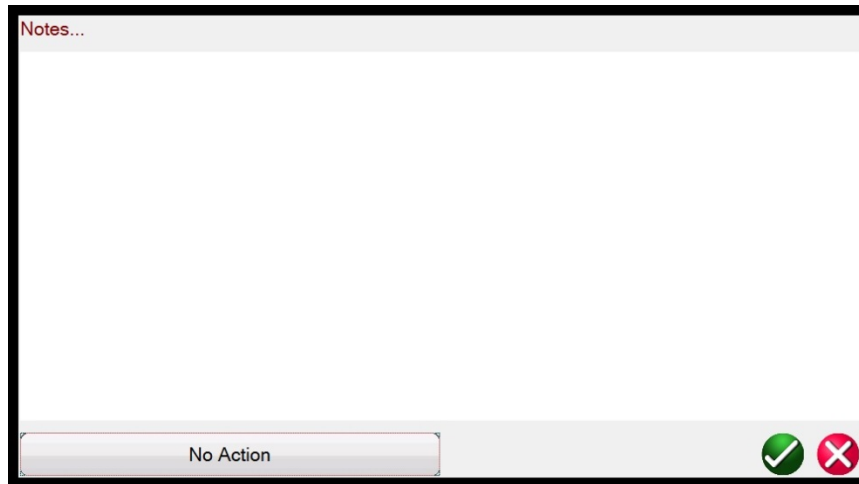

Figure 252 Test Notes Screen

Pressing the No Action button at the bottom of the note screen will provide options as shown in the following figure.

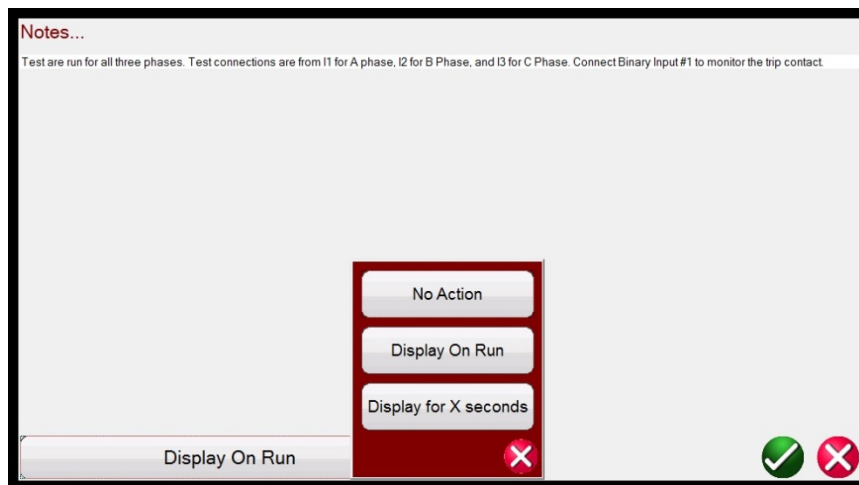

Figure 253 Test Notes and Display Action

The user can select to have the test notes displayed upon running the test, or not, or display for X number of seconds.

#### 3.14.1.1.6 Help button

The Help button is sensitive to the test and will take the user to this section of the manual.

### 3.14.1.1.7 Edit Test Attribute Script button



Pressing this button will take the user to the Edit Test and Attributes screen as shown in the following figure.

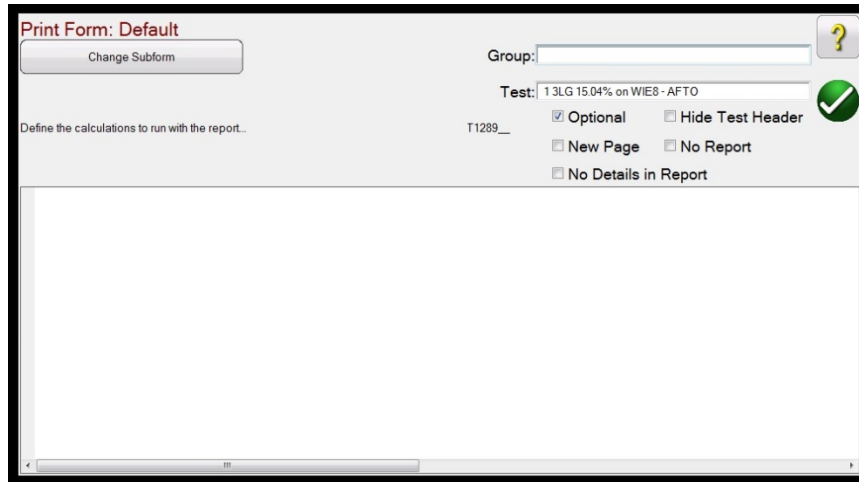

Figure 254 Edit Test and Attributes Screen

The **user can change the Group and Test names**. Checking the **No Report** button will exclude this test from Pass/Fail evaluation in the Test Report. Checking the **New Page** will add this test as a new page in the test report. **No Details in Report** does not apply to SS1 tests. Pressing the **Change Subform** button will present the following options to the user.

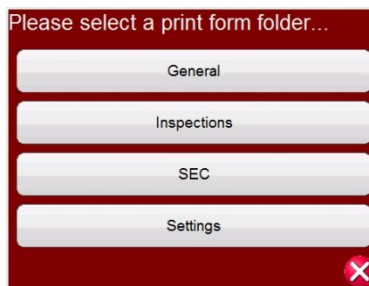

Figure 255 Change Subform Options in the Test Edit and Attributes Screen

Selecting any of the listed options will present the user with multiple lists of print labels.

### 3.14.1.1.8 Extended Actions List button

Pressing this button will provide a list of extended actions that the user may want to use, see the following.

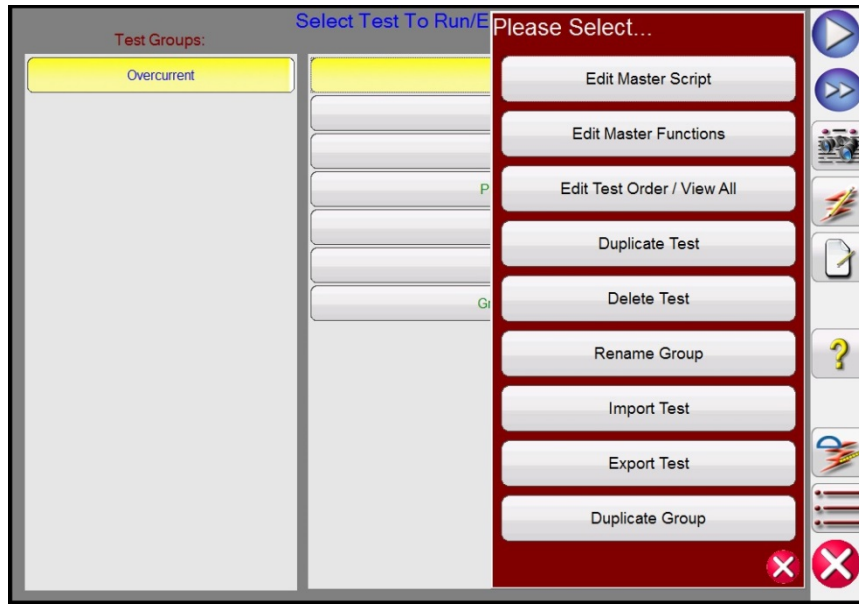

Figure 256 Extended Action List

Here the user can duplicate a Group of tests or Duplicate any individual test. Test can be Imported or Exported. The Group can be renamed. Test can be deleted here. The Edit functions do not apply to SS1 test files.

#### 3.14.1.2 Wait on IRIG-B

This start option is normally associated with conducting an End-To-End test. Connect the IRIG-B time source to Binary Input #1.



Note that Binary Input #1 is used to decode the IRIG-B time code (**requires the IRIG button is enabled in the Configuration screen**). Therefore, connect the relay trip contacts to Binary Input #2. RTMS automatically selects Binary Input #2 for trip/timer stop.

**Delay After Trigger** contains an edit field for time adjustments to the SMRT test set. The adjustments are to manipulate time **in ms** for synchronization between test sets of different manufacturer or models involved in playback of the file Tests and States. If using only SMRT units, no time adjustment is required. If using another test set from a different manufacturer on the other end of the line, the start time of the Megger test set will need to be adjusted to coincide with the start of the other unit. Contact your local Megger sales representative or technical support for more information.

Upon pressing or clicking on the blue Run Test button, the following screen will appear.



Figure 257 Setting IRIG-B Trigger Time

The user can click or press the IRIG-B Time for Test window and enter an appropriate time to start the test or can press or click on one of the two time setting buttons to automatically set the start time to be either +1 or +5 minutes into the future. It is vital that both test systems are set to the same time to start. When the IRIG-B start time is reached the test will start.

### 3.14.1.3 Wait Contact

The Wait Contact is like the Wait IRIG-B. It can be used to start the test from an external dry contact, such as might be found on older GPS units. The same Delay After Trigger applies like that described above.

## 3.15 IEC 61850 Megger GOOSE Configurator (MGC)

The Megger GOOSE Configurator software (MGC) provides mapping of the binary inputs and outputs of the SMRT test set to the desired GOOSE messages. The GOOSE messages are read from available SCL (Substation Configuration Language) files or may be automatically detected by scanning the substation network in search of available published GOOSE messages. This scanning process is known as GOOSE “sniffing.” The MGC also provides advanced network troubleshooting tasks such as comparing the GOOSE messages available on the network with the GOOSE messages described in the SCL files with GOOSE MERGE/COMPARE functionality; this is also a powerful tool for validating the horizontal communication description (GOOSE) in the supplied SCD file at Factory Acceptance Tests (FAT) in IEC 61850 substations. This type of verification is also known as GOOSE Consistency Check.

An SCL file is an XML (Extensible Markup Language) file that describes the IEDs available in one IEC 61850 substation (SCD file) or can just describe only one single IEC 61850 device (ICD, CID files). In the SCL file there are several IEC 61850 information available (logical nodes in the IEDs, GOOSE messages sent by the IEDs, GOOSE messages received by IEDs, Reporting information to SCADA etc.).

### 3.15.1 GOOSE Message Description

GOOSE is an acronym for Generic Object Oriented System Event (GOOSE). A “GOOSE message” is an intentional simplification. The GOOSE message is a digital frame (message) containing a lot of information, including the dataset. A dataset can contain different information like real values (analog GOOSE information, like RMS value of a measured quantity), integer values (e.g. BCD position of one power transformer tap changer), Boolean values (single point GOOSE information, e.g. the trip signal from the protection relay) and 2-bit string information (double point GOOSE information, e.g. the position of the circuit breaker). The MGC allows mapping of the binary information of the dataset (single point and double point) to the binary inputs and binary outputs of Megger relay test set.

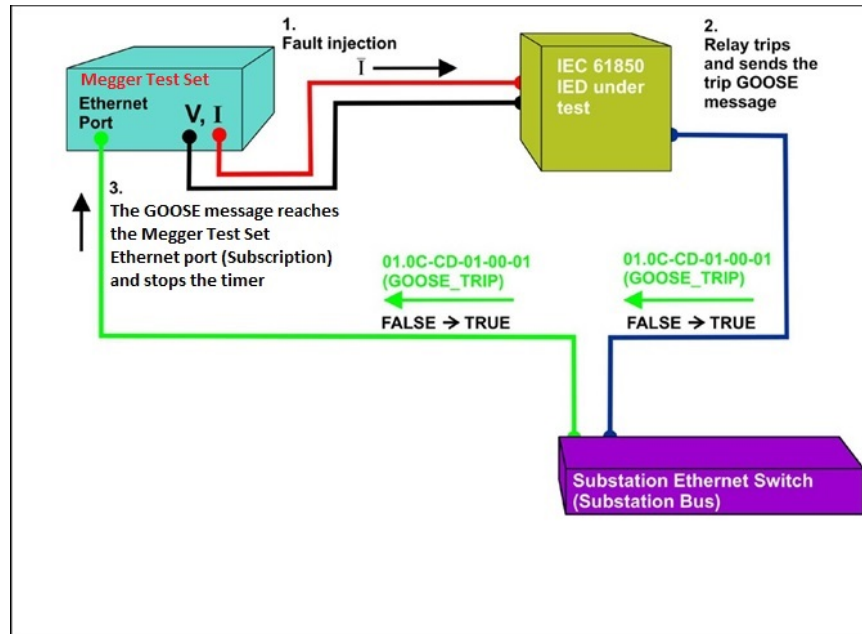

Figure 258 Trip test of an IEC 61850 IED with the IEC 61850 GOOSE interface.

### 3.15.1.1 IEC 61850 Relay Testing – General Description

The Megger relay test system is connected to the IEC 61850 station bus (or directly to the Ethernet port of the relay) and is programmed to map the trip GOOSE message from the tested IED to a chosen binary input. The mapped binary input is programmed to stop the timer of the Megger test set. This last action is done using RTMS. For testing IEC 61850 relay applications, where the protection relay needs an external signal to allow protection functions (e.g., external direct inter-trip command, or external auto-recloser start, or breaker failure start), it is necessary to “energize” the IEC 61850 relay with a GOOSE message. The Megger relay test set, which is still connected to the IEC 61850 station bus, is now programmed to map a binary output to a defined GOOSE message that is published by the SMRT. The test set activates its binary output when the test requires it, which means that the GOOSE message changes its status from “0” (false) to “1” (true). In a practical situation both applications (publishing of a GOOSE message and subscription of a GOOSE message), are often used simultaneously.

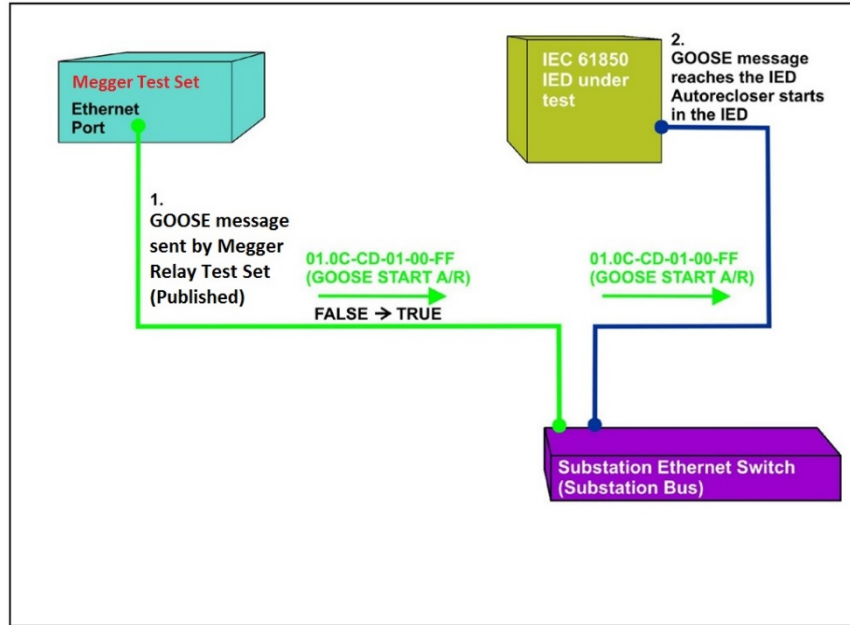

Figure 259 External relay energization (auto-recloser start) test of an IEC 61850 IED with a SMRT equipped with the IEC 61850 GOOSE interface.

### 3.15.2 MGC Menus

The following are descriptions of the MGC Menus

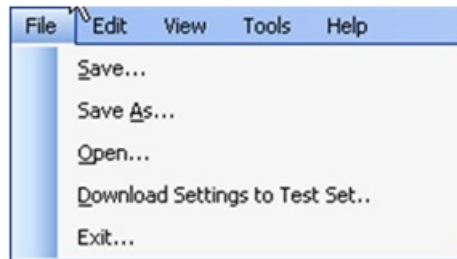

Figure 260 MGC Tool Bar Menu

#### 3.15.2.1 File Tab

##### 3.15.2.1.1 Save

This option allows the user to save a \*.mgc file. This file will contain all GOOSE messages used to configure the test set, and all the created tabs for GOOSE message sniffing, or for GOOSE messages imported from SCL files. The \*.mgc file will also contain the mappings to binary inputs and outputs.

##### 3.15.2.1.2 Save As

This is like save except it allows the user to create a new \*.mgc file with a different name.

### 3.15.2.1.3 Open

Opens an \*.mgc file.

### 3.15.2.1.4 Download Settings to Test Set

This function is used to download (writing) a mapping configuration to the test set.

### 3.15.2.1.5 Exit

Closes the MGC.

### 3.15.2.2 Edit Tab

All operations in this menu affect the GOOSE messages in the active tab. No changes will be made until the new configuration is downloaded. The following are descriptions of the Edit Tab Menu.

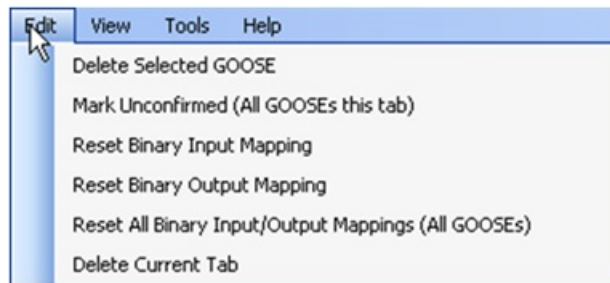

Figure 261 Edit Tab Menu

#### 3.15.2.2.1 Delete Selected GOOSE

Will delete selected GOOSE message(s) from the active tab.

#### 3.15.2.2.2 Mark Unconfirmed (All GOOSE messages this tab)

Will mark captured GOOSE messages as unconfirmed. This is helpful to determine if a particular GOOSE message is found within the network. All imported GOOSE messages from SCL files are unconfirmed.

#### 3.15.2.2.3 Reset Binary Input Mapping

Will reset all mappings to binary inputs under the MyGOOSE tab.

#### 3.15.2.2.4 Reset Binary Output Mapping

Will reset all mappings to binary outputs under the MyGOOSE tab.

#### 3.15.2.2.5 Reset All Binary Input/Output Mappings (All GOOSE messages)

Will reset all mappings to binary inputs and outputs under the MyGOOSE tab.

#### 3.15.2.2.6 Delete Current Tab

Will delete the visible tab. The MyGOOSE tab cannot be deleted.

### 3.15.2.3 View Tab

The following are descriptions of the MGC View Tab

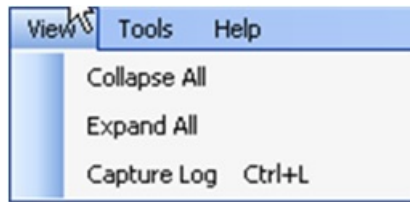

Figure 262 The View Tab Menu

#### 3.15.2.3.1 Collapse All

If a GOOSE message is expanded, this command will collapse all GOOSE messages.

#### 3.15.2.3.2 Expand All

Expand all will show all the properties of the GOOSE messages.

#### 3.15.2.3.3 Open Log

This menu allows the user to view the log file containing all the user's and MGC operations.

### 3.15.2.4 Tools Tab

The following are descriptions of the Tools Menu Tab

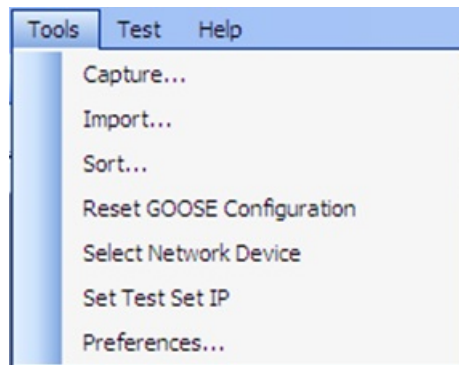

Figure 263 Tools Tab Menu

#### 3.15.2.4.1 Capture

Use to “sniff,” i.e., capture, GOOSE messages from a network device. This will open the select network interface window (Ethernet port) if no interface has been selected previously in this session.

#### 3.15.2.4.2 Import

Use to import GOOSE messages from an SCL type file. These files have an extension of .SCD, .CID, or .ICD (IEC 61850 standard, Edition 1). This will open a browse window to select an SCL file to open.

#### 3.15.2.4.3 Sort

Use to sort GOOSE messages in either descending or ascending order.

#### 3.15.2.4.4 Reset GOOSE Configuration

Use to reset the test set GOOSE mapping configurations.

#### 3.15.2.4.5 Select Network Device

Use the display window below allowing choosing of the Ethernet port of the PC that will be used to sniff (capture) the GOOSE messages and to communicate to the Megger test set. In normal situations, this PC Ethernet port is connected to the front port of the test set.



Figure 264 Selecting Ethernet Port

#### 3.15.2.4.6 Set Test Set IP

Display window used to enter IP address of the front port of the Megger test set to allow the download of the GOOSE mapping.



Figure 265 Window for Setting IP address.

#### 3.15.2.4.7 Preferences

The following are descriptions of the Preferences screen selections.

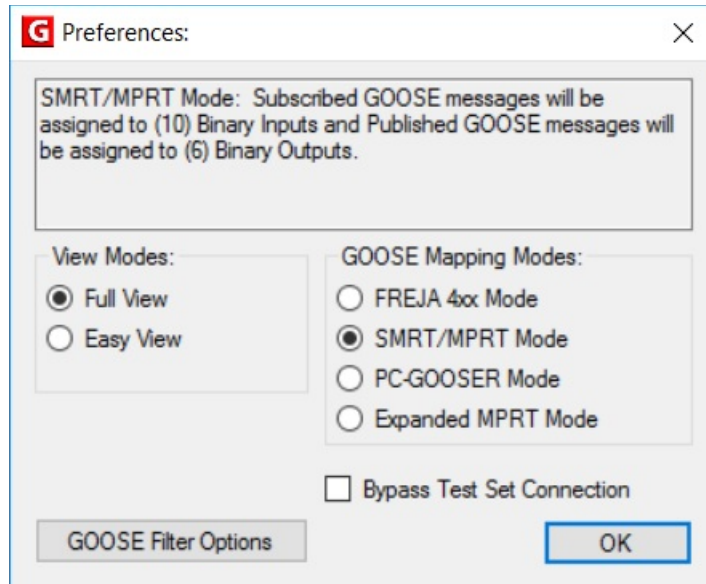

Figure 266 Preferences Screen Selections

### 3.15.2.4.7.1 Full View

In Full View, all information associated with GOOSE messages will be shown. See the following example.

IEC GOOSE[GOOSERLD0/LLN0\$G0\$G_B02][01-0C-CD-01-F0-02]	
IED(3)	
-	IEDName: GOOSER
-	IEDName + LDName: GOOSERLD0
-	IED IP ADDRESS: 10.1.150.3
Attributes(11)	
-	GOOSE CONTROL BLOCK NAME: G_B02
-	GOOSE CONTROL BLOCK FULL NAME: GOOSERLD0/LLN0\$G0\$G_B02
-	DESCRIPTION: B02
-	GOOSE MAC-Address: 01-0C-CD-01-F0-02
-	VLANID: 1 (0x001)
-	VLAN PRIORITY: 4
-	GOOSEID (GoID): MEGGER
-	APP ID: 2 (0x0002)
-	DATASET NAME: DS2
-	DATASET FULL NAME: GOOSERLD0/LLN0\$DS2
-	Config Revision: 2
DataSet(2)	
-	[1] BOOLEAN (LD0.SP16GGI01.ST.Ind2.stVal)
-	[2] BITSTRING (LD0.SP16GGI01.ST.Ind2.q length: 13)

Figure 267 Full View GOOSE Messages

### 3.15.2.4.7.2 Easy View

In Easy View, the most used information associated with GOOSE messages will be shown. If not, advanced GOOSE troubleshooting is performed, this is the suggested view for the user.

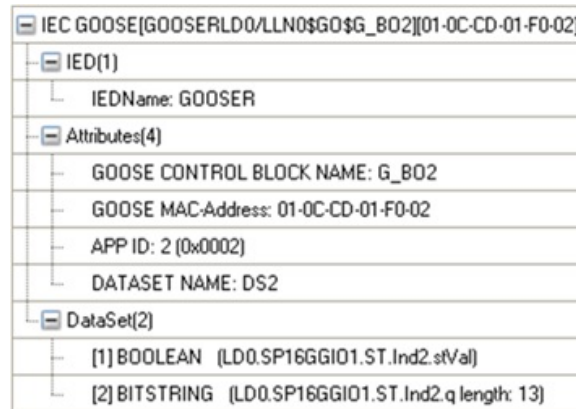

IEC GOOSE[GOOSERLD0/LLN0\$GO\$G_B02][01-0C-CD-01-F0-02]	
IED(1)	
IEDName:	GOOSER
Attributes(4)	
GOOSE CONTROL BLOCK NAME:	G_B02
GOOSE MAC-Address:	01-0C-CD-01-F0-02
APP ID:	2 (0x0002)
DATASET NAME:	DS2
DataSet(2)	
[1] BOOLEAN	(LD0.SP16GGI01.ST.Ind2.stVal)
[2] BITSTRING	(LD0.SP16GGI01.ST.Ind2.q length: 13)

Figure 268 Example of Easy View GOOSE Message

### 3.15.2.4.7.3 FREJA 4xx Mode

This allows MGC to work with Megger FREJA 4xx relay test sets.

The GOOSE messages will be assigned to FREJA 4xx binary inputs (subscription) and binary outputs (publication).

### 3.15.2.4.7.4 SMRT/MPRT Mode

This allows the MGC to work with SMRT or FREJA 5xx units, or older legacy MPRT units, equipped with IEC 61850 interface. The GOOSE messages will be assigned to MPRT, SMRT, or FREJA 5xx binary inputs and outputs.

### 3.15.2.4.7.5 PC-GOOSER Mode

This allows MGC to work with the general-purpose IEC 61850 GOOSE test equipment, the GOOSER. The GOOSER production has been discontinued.

### 3.15.2.4.7.6 Expanded MPRT Mode

In this mode, all subscribed or published GOOSEs can be assigned to either binary inputs or outputs. If a GOOSE message contains various indications, then those indications can be mapped to either input or output. The following figure shows a GOOSE with indication one being mapped to input 6 and indication two being mapped to output 6. Notice in this mode it is difficult to determine whether a GOOSE is a published or subscribed. This type of application is uncommon.

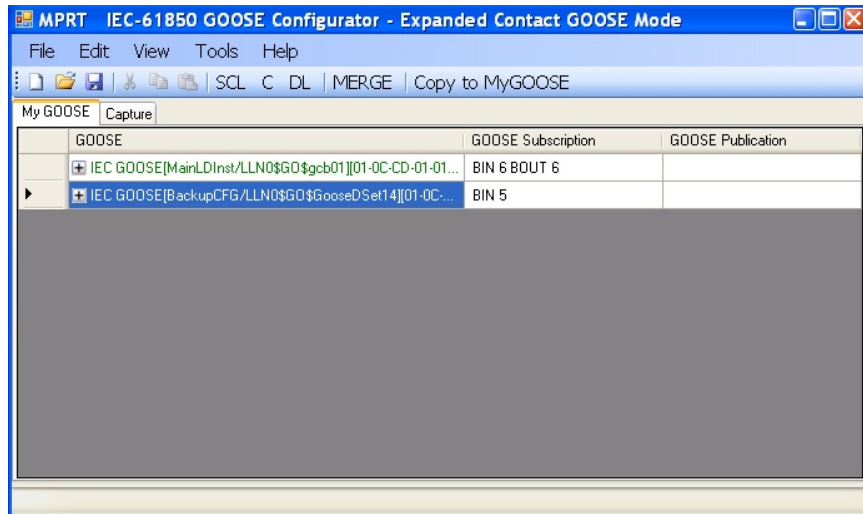

Figure 269 MPRT Expanded Mode Screen

#### 3.15.2.4.7.7 Bypass Test Set Connection

Allows MGC to scan the network without having a test set as Secure Network Access Point.



**Note:** In this case the PC Ethernet port is directly connected to the substation bus. This operating mode is only for advanced users that have full control over the messages that the PC may eventually send on the substation bus. It is **not recommended** during maintenance testing, or anyway when the substation is in operation. If you are unsure, always connect your PC to the ISOLATED port of the Megger relay test equipment, and then connect the IEC 61850 port to the substation bus.

#### 3.15.2.5 GOOSE Filter Options

GOOSE filter options allows the user to add GOOSE messages to the FILTER tab. To do it, select a GOOSE message, do right click on it, and select "Add to GOOSE Filter".

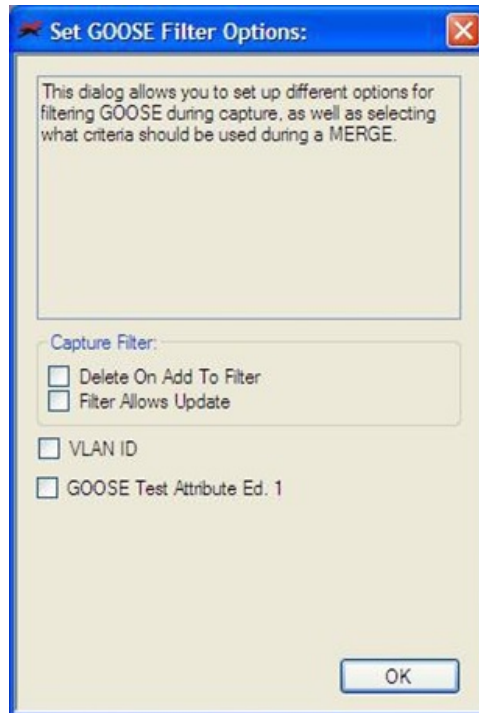

Figure 270 MGC GOOSE Filter Options Screen

#### 3.15.2.5.1 Delete On Add To Filter

This option will remove selected GOOSE messages from the current tab when added to the FILTER tab.

#### 3.15.2.5.2 Filter Allows Update

This option allows only the GOOSE messages in the FILTER tab to be captured/updated, with the next Capture operation. If not selected, the GOOSE messages in the FILTER tab will be ignored within the next Capture operation and will not be added/updated. Remove (delete) the Filter tab if you want to easily get rid of any filtering.

#### 3.15.2.5.3 VLAN ID

In this window it is also possible to affect the GOOSE MERGE algorithm and decide if some important parameters like the VLAN tag and the Test Attribute should be used to discriminate if two messages are equals or different. If selected, two GOOSE messages with different attributes will not be merged in a MERGE operation. This means that if one SCL-GOOSE and one sniffed-GOOSE are equal in all their parameters, but the VLAN tag is different, they will not be merged as they will be considered as different messages. If not selected, the VLAN attributes will be ignored in a MERGE operation.

#### 3.15.2.5.4 GOOSE Test Attribute ED. 1.

If selected, two GOOSE messages with different value (True or False) of the Test Attribute will be considered different and will not be merged. This means that if one SCL-GOOSE and one sniffed-GOOSE are equals in all their parameters but different in the Test Attribute, they will not be merged. If not selected, the Test Attribute will be ignored by the MERGE algorithm. This means that if one SCL- GOOSE and one sniffed-GOOSE are equals in all their parameters but different in the Test Attribute, they will be considered equals and will be merged.

### 3.15.2.6 Test Tab

#### 3.15.2.6.1 IEC 61850-8-1 Ed. 1 Test

With this menu it is possible to manipulate the test service parameter and to manipulate the test bits in the test quality attributes of the published GOOSE messages by the Megger relay test set.

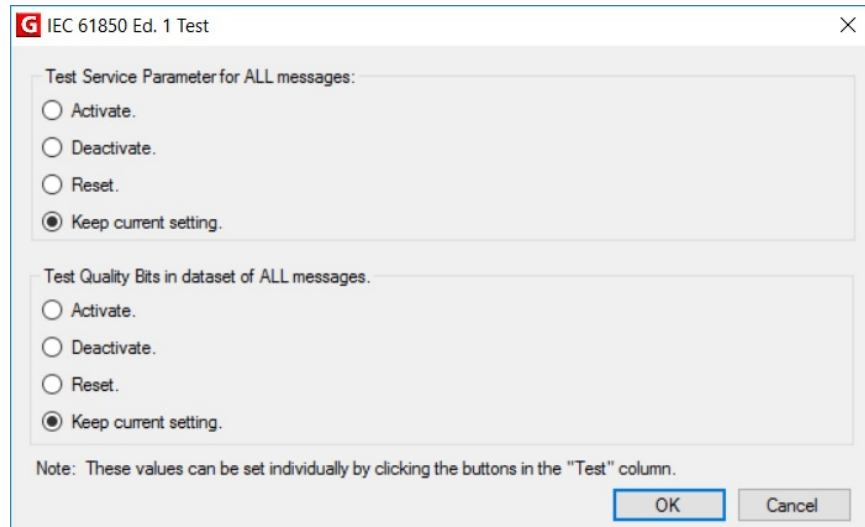

Figure 271 IEC 61850 Ed.1 Test Selection Menu

### 3.15.2.7 Help Tab

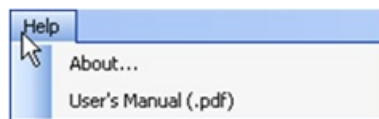

Figure 272 MGC Help Tab

#### About

The help option will display the version of the software.

#### User's Manual

Opens the user's manual (Acrobat Reader must be installed).

### 3.15.3 MGC Toolbar

The MGC buttons provide a shortcut to either importing or capturing a GOOSE message without navigating through the tool bar. The various buttons are shown in the following figure.

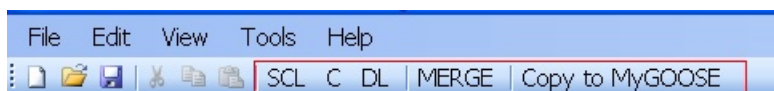

Figure 273 MGC Tool Bar

### 3.15.3.1 SCL Button

Import GOOSE messages from an SCL file.

### 3.15.3.2 C Button

Capture (sniff) GOOSE messages from the network.

### 3.15.3.3 DL Button

Download writing settings to test set.

### 3.15.3.4 MERGE Button

This will merge captured and imported GOOSE messages into one tab.

### 3.15.3.5 COMPARE Button

This button appears if a MERGE tab exists. It is possible to select two GOOSE messages from the MERGE tab and by clicking on COMPARE they will appear in a new tab with the list of the differences in the two selected GOOSE messages. This is helpful when the MERGE algorithm fails with some messages to easily understand what the differences are. If there is no MERGE tab, this button is grayed.

### 3.15.3.6 Copy to MyGOOSE Button

Copy a GOOSE message to MyGOOSE tab. The MyGOOSE tab is where all GOOSE messages are assigned to either binary inputs or outputs. Multiple selection is possible (SHIFT Click).

### 3.15.3.7 New Search Button

Selecting this option opens a search dialog where it is possible to define parameters to search for GOOSE messages.

Figure 274 MGC Search Tab

<<Previous

This will jump to the previous match as defined in the search filter.

Next>>

This will jump to the next match as defined in the search filter.

### 3.15.4 Network Scanning

One way of determining the health of the system is by monitoring the network traffic. Station communication consists of many components of which GOOSE communication is one. Using MGC it is possible to scan the network for GOOSE communication and when wanted to use this information to configure the Megger test system for subscription or publication of GOOSE messages. Scanning the network may also be of help when troubleshooting.

#### 3.15.4.1 How to capture GOOSE Messages

Capturing GOOSE messages from the network is another method of importing them into the MGC software.

1. Connect the PC to the PC or ISOLATED port on the Megger relay test system. If using the MGC Onboard in RTMS Enhanced there is no need to connect a PC.
2. Connect the substation Ethernet switch (substation bus) to the Megger relay test set IEC 61850 port.
3. MGC application is then started.

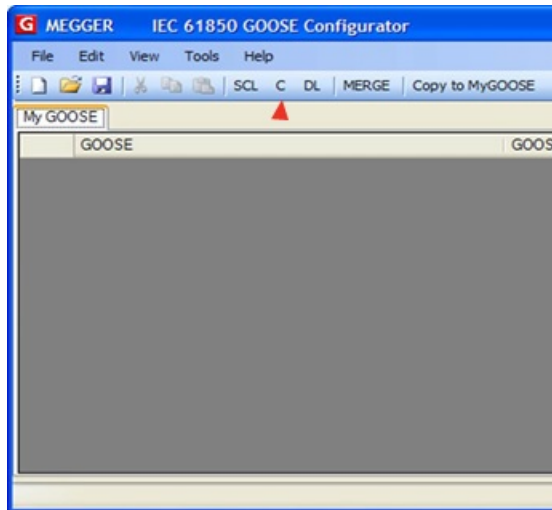

Figure 275 Using the Capture button.

- Click the button "C" (or use "Tools"- "Capture") MGC will ask which Ethernet port of the PC is expected to be used for the communication with MGC.



**Note** It is recommended to have the PC Ethernet port address compatible with the IP address of the Megger relay test setport.

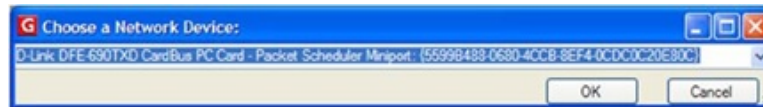

Figure 276 Selecting PC Ethernet Port

Set the test set IP Address.

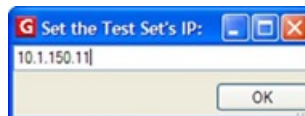

Figure 277 Setting Test set IP address.

- After a device is selected, the "C" button will turn green, and messages will start to appear as they are captured. A capture session will last until the C button is clicked once again.
- When the wanted GOOSE messages appear on the screen stop the scanning by clicking on "C" again.

All captured messages are displayed in green. Every time a captured session is initiated, a separate tab is created that will contain all the captured messages.

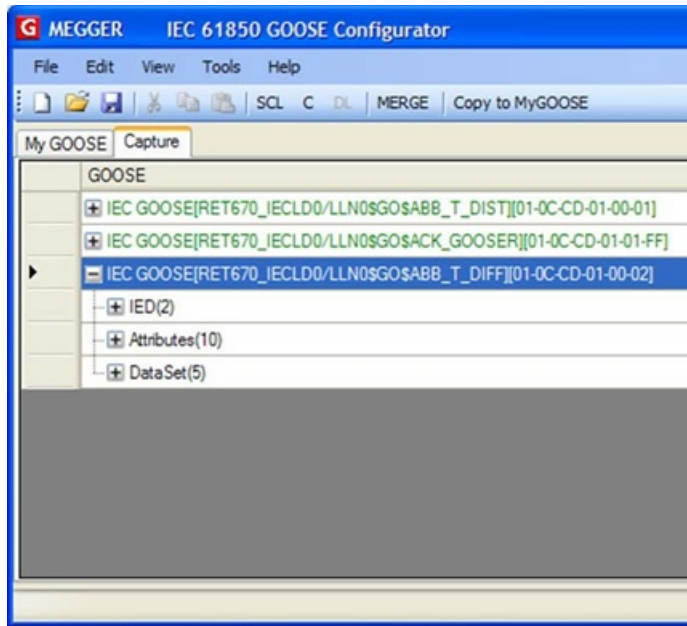
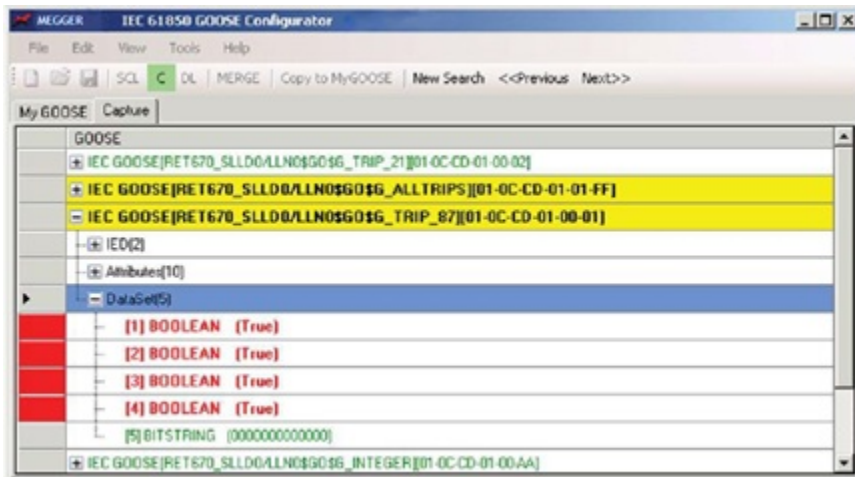

Figure 278 Captured GOOSE Messages

### 3.15.4.2 How to Monitor GOOSE Messages

While running a Capture process, the MGC will show the state of the captured signals. Any change of state will be highlighted with color change of the signal, purple for off (false) and red for on (true).



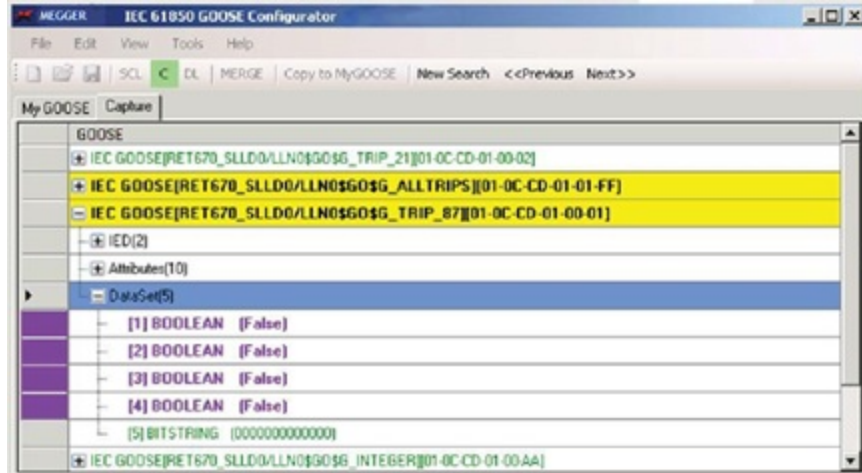

Figure 279 Example State Change of Captured GOOSE Messages

### 3.15.5 GOOSE Message Analysis

Many different types of messages are transported using the same network. The built-in sniffer in MGC helps by showing only GOOSE messages and filtering out any other type of Ethernet messages. Even if this narrows down the amount of traffic that may need to be analyzed, there still may be a substantial amount of information that needs to be sorted out before getting down to the wanted details. There are several tools that can be utilized to find the wanted information from the network, i.e., VLAN ID warning dialog, Filter, Merge, and confirmation.

#### 3.15.5.1 GOOSE Filter

There can be large numbers of GOOSE messages in the network to be analyzed, and it may be cumbersome to do a full capture and find the wanted messages amongst all other messages. In this case the filter functionality can be used to filter out any other message than the ones under investigation. Filtering is done by selecting a GOOSE message from any tab, right-click on that message and select “Add To GOOSE Filter.” This will add the message to a new tab, if not already there, called FILTER. Next time a capture is done only messages in the filter tab are captured. The settings for the filter can be found under Tools | Preferences | GOOSE Filter Options. Here it is also possible to select if the GOOSE message being added to the filter shall be removed from the tab from where it is selected. This may be useful to keep track of which messages have been analyzed.

#### 3.15.5.2 MERGE

When capturing, there may be different GOOSE messages on the network than expected. This is where MERGE can be utilized to check if one GOOSE message on the network is different than one GOOSE message described on the SCL file. Merge compares the messages in a SCL file with a captured session. That is, when capturing messages from the network and importing a SCL file containing messages that should be available on the network, it is possible to see if the messages really are there and if a significant parameter of the messages has been changed. A more detailed description of how to use merge can be found in next section.

#### 3.15.5.3 COMPARE

If the MERGE between two GOOSE messages fails, it is because the two messages have some differences. It is possible to have information of all the differences between two GOOSE messages by selecting them (from the MERGED tab) and by clicking on COMPARE. This way it will be easy to

understand what the difference between the GOOSE messages is. This difference is usually the cause of non-reception of a GOOSE message from some IEDs: there are some differences between the expected GOOSE (described in the SCL file) and the available GOOSE (published on the network).

#### 3.15.5.4 Confirmation

All captured GOOSE messages are confirmed, i.e., they really exist on the network, and are thus marked with green color. All GOOSE messages imported from a SCL file are considered unconfirmed and are colored black. When capturing GOOSE messages, it may be difficult to see if a particular GOOSE message performs any operations. By marking the signal or the whole GOOSE message unconfirmed it is possible to see what signals have data that changes. If data changes the color of the GOOSE message will return to green color, otherwise it will remain colored black, which then means that the signal is not alive in the network even if the GOOSE message is present.

#### 3.15.6 Merging of GOOSE messages

When analyzing the IEC 61850 GOOSE communication in a substation, it is assumed that the list of GOOSE messages detected from the network scanning is equal to the list of GOOSE messages listed in the SCL file describing the substation (SCD). Not only the list, but also the GOOSE attributes of the scanned GOOSE message and the SCL GOOSE message are to be the same. It may happen that the scanned GOOSE messages differ from the SCL file messages. These differences can bring failure in some IEDs to receive GOOSE messages that “seem OK” from the network scanning point of view. The MGC application allows a “MERGE” of the network scanned GOOSE information with the SCL file GOOSE information. If two GOOSE messages, one scanned and one in the SCL file, are exactly equal, then they are merged into one GOOSE message. If there are any differences they are not merged. You can then verify the GOOSE messages that have not been merged and find the differences than can explain why some IEDs are not able to receive the published GOOSE messages.

##### 3.15.6.1 MERGE and COMPARE example.

In this example, there are two IEDS. The SCD file for the substation describes the GOOSE messages that both IEDs are expected to send:

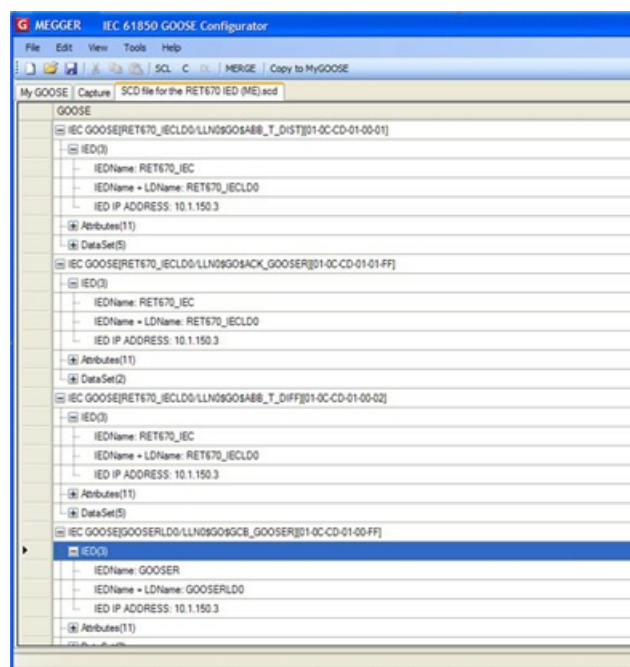

The two IEDs are “RET670\_IEC” and “GOOSER”. The “RET670\_IEC” is configured to send three GOOSE messages, as can be seen from the picture above. Only “RET670\_IEC” is connected to the substation bus.

By scanning the substation bus the following GOOSE messages are detected:

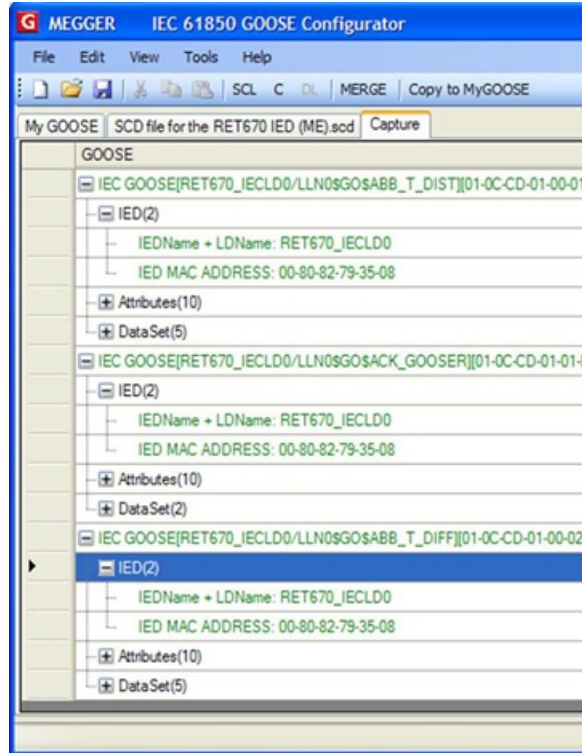

Figure 280 Captured GOOSE Messages



**Note:** In the published GOOSE messages the single information “IED name” is not available, where “IED Name + LD Name” (IED name + Logical Device name) is used instead. This is because the (IED name + Logical Device name) is not published in the GOOSE message.

To do the “MERGE” between the scanned GOOSE messages and the SCL GOOSE messages, press the “MERGE” button. The result is shown below in the “MERGED” tab:

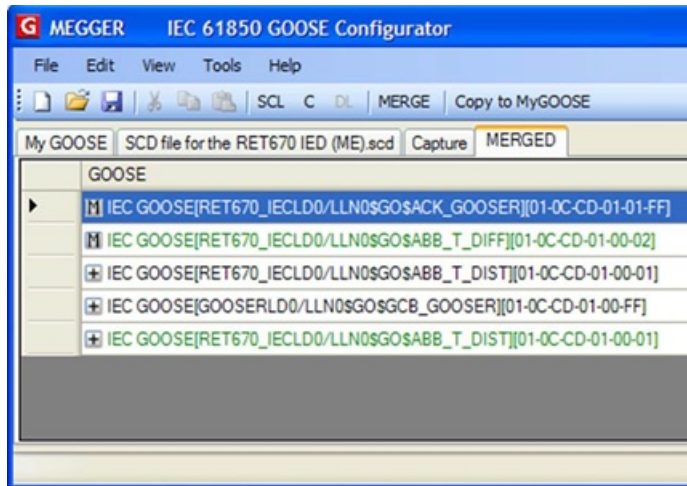

Figure 281 Merged GOOSE Messages

You can see that 2 messages have been successfully merged (the icon “M” indicates this). This means that these two messages are identical with the information on the SCD file: the IEDs in the substation are publishing the GOOSE messages exactly as it is configured in the SCD file. By “exploring” the first merged GOOSE message you can see that the MGC has Merged the SCL information with scanned data information.

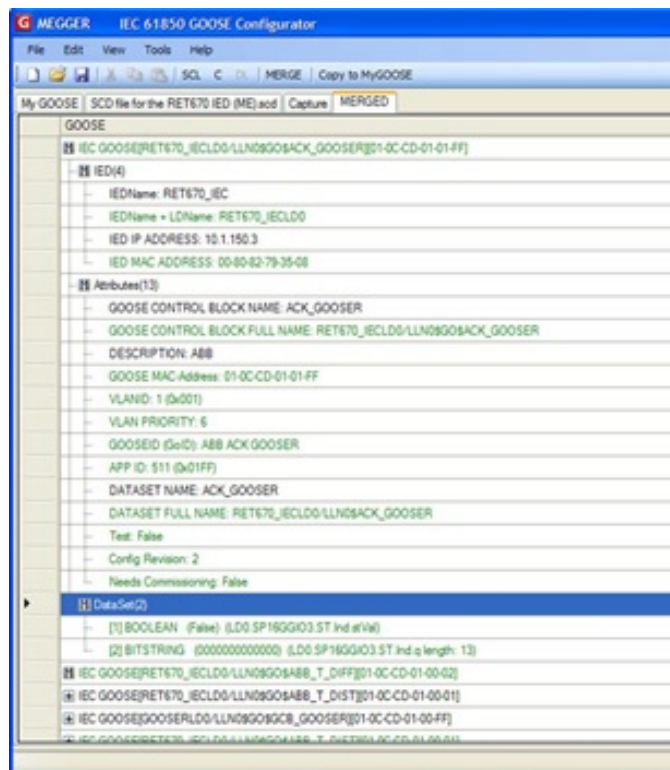

Figure 282 Exploring the Merged GOOSE Messages

For this example, the IED IP Address is only available in the SCL file (and not on the published message), while the MAC Address of the IED Ethernet port is only available on the published message (but not on the SCD file):



Figure 283 IED IP Address in the SCL File

For the dataset you can also see that the data object information (name of the single information in the dataset), only available on the SCD file, has been merged with the raw information (Boolean) available on the published message:

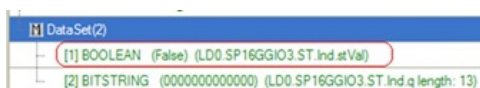

Figure 284 Merged Boolean Information

What is useful at this stage is that: the successful MERGE indicates that the published merged GOOSE messages are in accordance with what has been configured in the SCL file, and the user has all the information that is useful to understand “what happens” in the substation. The “Boolean” indication for the dataset is not very meaningful, but when integrated with the SCL information “SP16GGIO3” it becomes more understandable that bit of the dataset represents the logical node SP16G- GIO, which is a standard IEC 61850 information. Moreover, there are indications from the “non- merged GOOSE messages.”

To understand why the GOOSE messages have not been merged needs some IEC 61850 experience and some manual investigation. The system is already able to pinpoint strange GOOSE messages by not merging them. Let us have a look at the non-merged GOOSE messages.

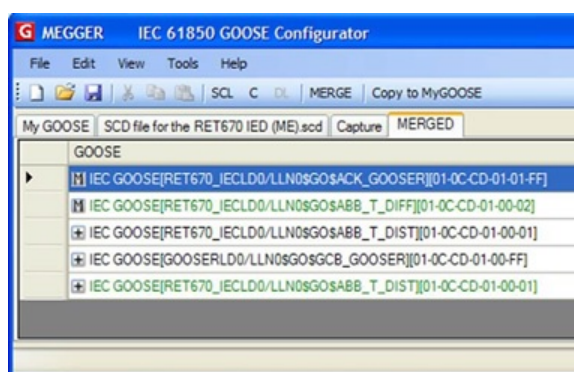

Figure 285 Merged and Non-Merged GOOSE Messages

The GOOSE with MAC Address “01-0C-CD-01-00-FF” is only available on the SCD file (in black color). It is hence not available on the station bus. The IED “GOOSER” (your relay test set) is not connected to the bus, thus it will not Merge with the SCL file. The message “01-0C-CD-01-00-01” is available on the bus (green color) and is in the SCL file. However, there is a difference in some data, so they are different. Why?

Let us explore the messages:

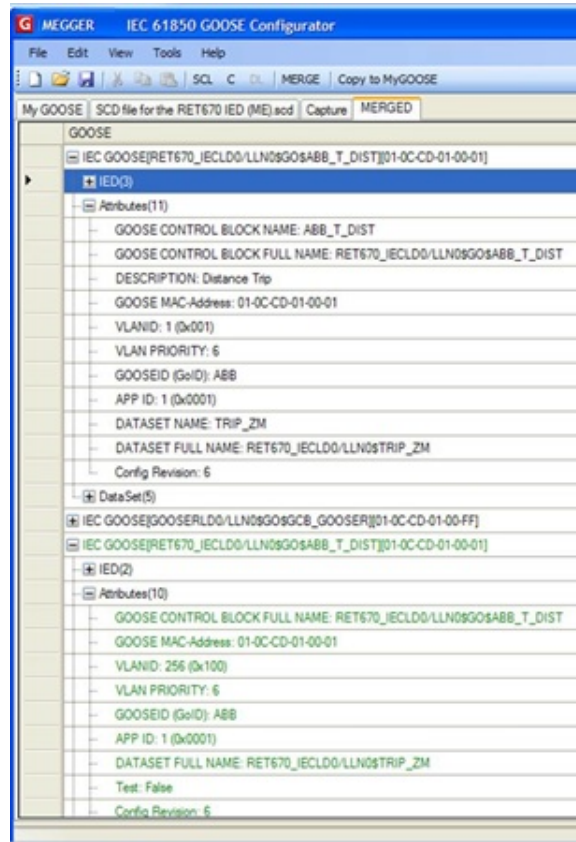

Figure 286 Exploring GOOSE Messages

You can see that the published GOOSE (green color) has a VLAN of 256. The engineered GOOSE (SCL GOOSE, black color) has a VLAN of 1. This difference can cause the one IED configured to receive this GOOSE message, might not do that. The IED is configured from the SCL file, and the published GOOSE is different. Why the IED has published a GOOSE message with a different VLAN than indicated in the SCD file cannot be analyzed by the MGC application and needs further investigation. One possibility is that the IED has been configured with a different version of SCD file, or the IED has misinterpreted the information in the SCD file. What is important is to be able to easily know that some messages are not really the same. It is possible to select the two messages that have not been merged, and ask MGC to show the differences between them, by using the COMPARE button.

### 3.15.6.2 COMPARE Example

In the following example, we can see one MERGED tab, where some GOOSE messages have not been merged, see fig. below.

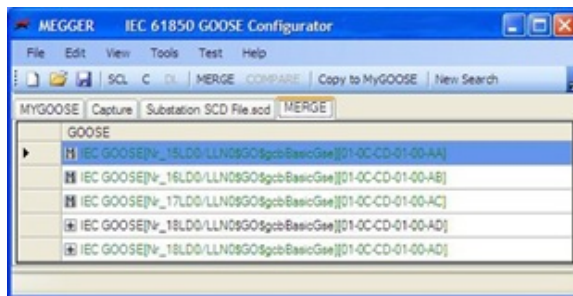

Figure 287 Merged and Non-Merged GOOSE Messages

Select the two non-merged messages (SHIFT-select or CTR-select on both) and click on COMPARE, see the following figure.

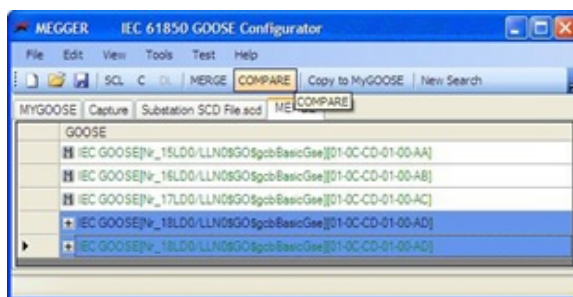

Figure 288 Comparing GOOSE Messages

You will get the new COMPARE tab, where the list of differences is shown, see the following figure.

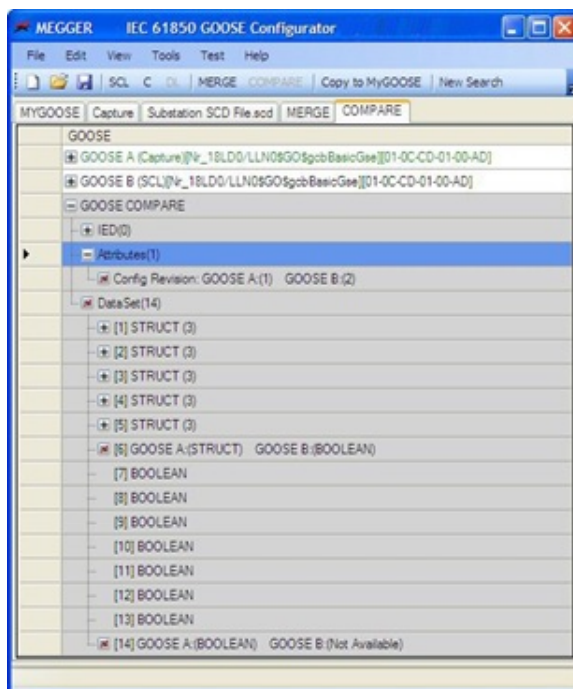

Figure 289 Comparison Differences

What can be seen as result from the COMPARE is that the SCL GOOSE contains a longer dataset than the published GOOSE. Moreover, the Configuration Revisions of the two messages is different: **one** in the published GOOSE, and **two** in the SCL GOOSE. This means with the most probability that after the installation of the publisher IEDs, the horizontal communication of the substation has been changed for the GOOSE 01-0C-CD-01-00-AD. Its dataset has been modified and correctly the IEC 61850 engineering tool has incremented the configuration revision (from 1 to 2). The SCL file does not correctly describe the substation, and the IEDs should be loaded with the new IEC 61850 information contained in the given SCD file.

### 3.15.7 Configuration

SMRT test sets can subscribe to or publish binary signals. Configuration must be done for the Megger relay test set to know which input(s)-, or/and output(s) shall be mapped to what GOOSE messages. Configuration is done by copying the wanted GOOSE messages to the "MyGOOSE" tab in MGC.

The general procedure for configuring the Megger relay test system is to find out what signals are available either by importing an SCL file, or by capturing GOOSE messages on the network, copy the wanted GOOSE messages to the "MyGOOSE" tab in MGC, and assign binary inputs- and/or outputs as appropriate.

IEDs publish and/or subscribe to GOOSE messages primarily for bay communication. The SCL file for the station provides complete information on what GOOSE messages are available. Another way of finding out what is available is to capture the traffic of the network and search for specific messages. Capturing is good if there are only a few signals, but as the description of the signals is incomplete in the message it can be time consuming to figure out what is available. Therefore, it is usually better to do the configuration using the SCL file for the station where all information is included, i.e., SSD or SCD files.

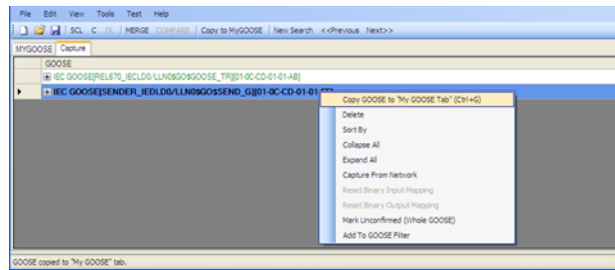

Figure 290 Selecting a captured GOOSE for operation and Copy to MyGOOSE

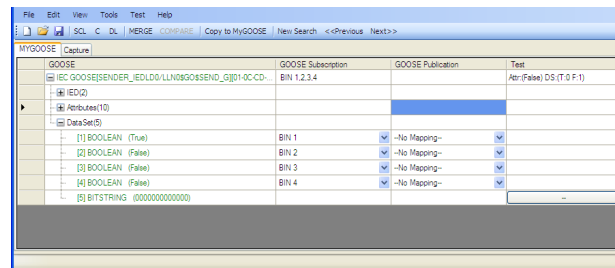

Figure 291 Mapping GOOSE Messages to Binary Inputs and Outputs

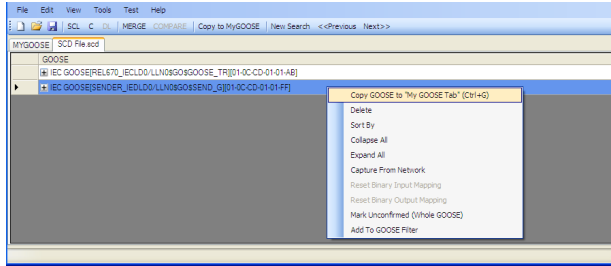

Figure 292 Selecting a GOOSE imported from an SCL-file for operation and Copy to MyGOOSE

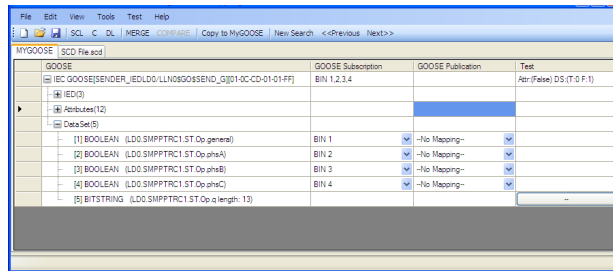

Figure 293 Mapping an Imported GOOSE in MyGOOSE

### 3.15.7.1 Mapping SMRT binary inputs to GOOSE messages (subscription)

This operation is necessary when the relay test set needs to react on some relay signals that in the conventional technology are relay contacts (trip, start power swing detected etc.) and in the IEC 61850 technology are represented by published GOOSE messages.

The action that needs to be done is to map the GOOSE message to a specific binary input. Once this is done the relay test is carried out in the same way as conventional technology. The relay test set is instructed to be stopped (in case of a trip test) by the desired binary input, which is mapped to a GOOSE receive message.

To do the mapping of the GOOSE dataset to the binary input the GOOSE message must be available on the "MyGOOSE" tab.

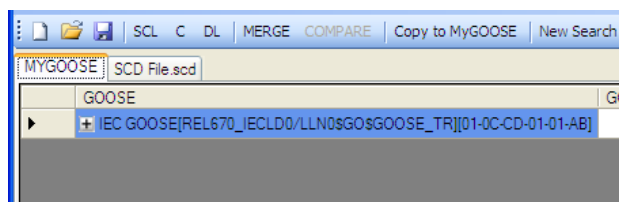

Figure 294 Imported GOOSE in MyGOOSE for Mapping

The GOOSE message "MyGOOSE" tab contains a dataset, and the bits information of the dataset are mapped to a binary input, see the following step by step description.

- 1] Click the + to expand.  
The dataset information is opened:

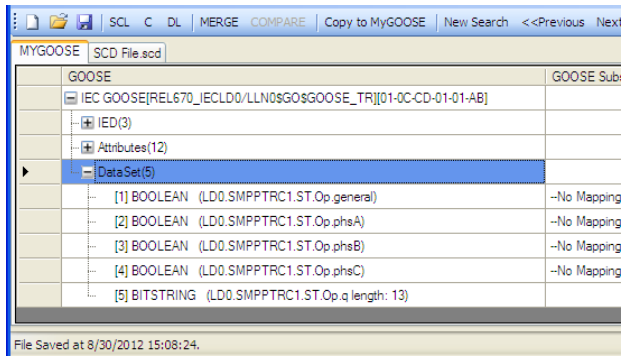

Figure 295 Opening DataSet

2] Select a bit (or several bits) of the dataset and map it to the wanted binary input under GOOSE Subscription.

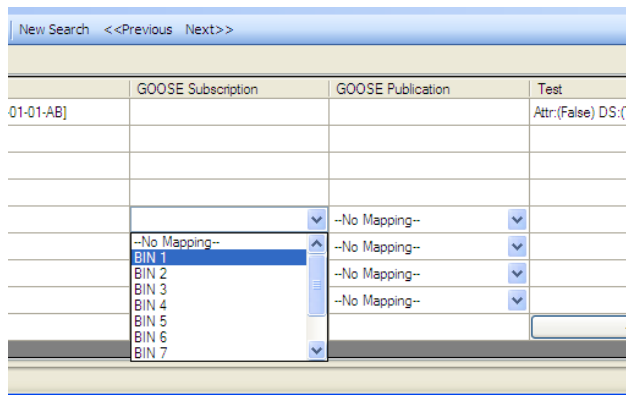
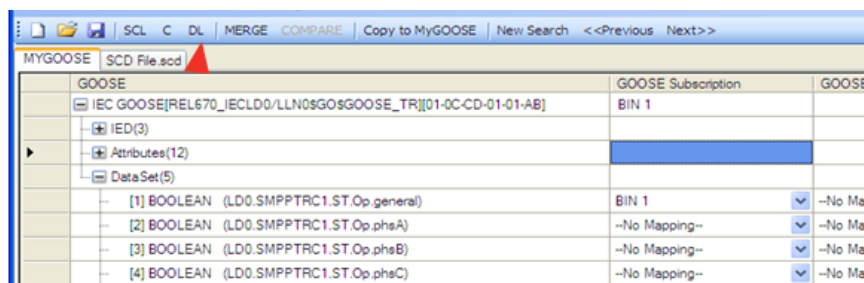

Figure 296 Mapping Binary Input #1 (BIN1)

When the choice is done, in the example the Relay Test Set will be instructed to map the bit n. 1 of the dataset to its binary input 1:

3] This information must then be sent (down- loaded) to the Relay Test Set by clicking on the button “DL” (download).



The MGC application will ask for the IP address of the test set Ethernet port.

4] Press the OK button to send the mapping information to the Relay Test Set.

After that the SMRT will behave according to how it has been instructed. For the given example this means that when the bit 1 of the dataset of the GOOSE message 01-0C-CD- 01-00-AB is "1", SMRT "believes" its binary input 1 is activated and when the bit is "0" the SMRT "believes" it is not activated.

### 3.15.7.2 Mapping SMRT binary outputs to GOOSE messages (publication)

This operation is necessary when SMRT needs to activate some signals to the relay under test. A typical example is the acceleration carrier, or the start of the auto-recloser, or the start of the circuit breaker failure protection. In conventional technology, this is done by activating the SMRT binary outputs that are connected to the relay binary inputs. For the IEC 61850 technology, a GOOSE message is sent by the SMRT into the protection device, and the value of the GOOSE message is associated to the status of the mapped binary output. When the output is open the GOOSE message has value "0" and when it is closed it has value "1".

The mapping is done in the same way as it is done for the binary inputs except that the dataset bits are mapped from the column "GOOSE Publication".

### 3.15.7.3 Manipulating the IEC-61850 test service parameter in published GOOSE messages.

The test attribute (formally more known as "Test Service Parameter") of the GOOSE messages published by the SMRT can be manipulated from the menu "Test/IEC 61850-8-1 Ed. 1 Test", see figures below.

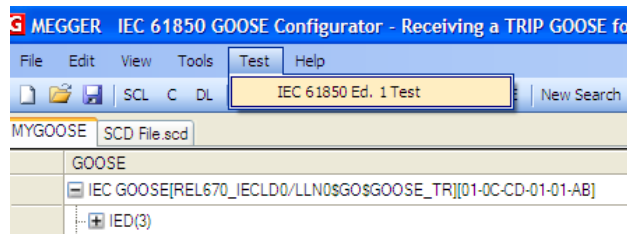

In the first half of the window shown above it is possible to manipulate the test service parameter of all GOOSE messages sent by the SMRT, which means that the messages are available under the MyGOOSE tab and are mapped to some binary outputs.

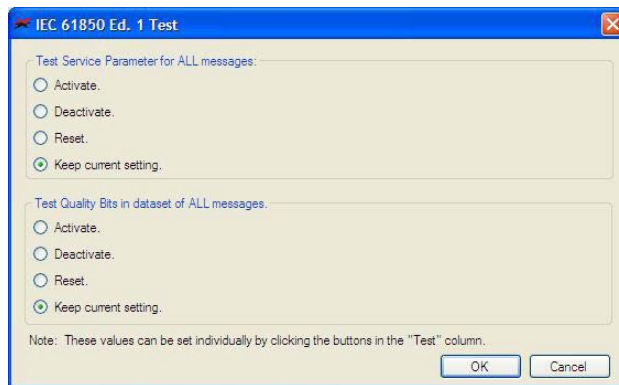

By choosing "Activate", all the test service parameters are set to TRUE, no matter what their original value was, see the following figure.

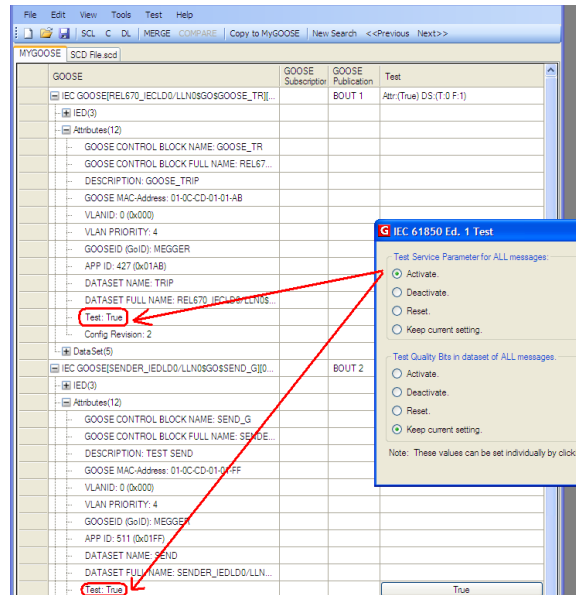

By choosing "Deactivate", all the test service parameters are set to FALSE, no matter what their original state was.

By choosing "Reset" all the published GOOSE messages will have the test service parameter value according to the original value. If SCL-GOOSE it is FALSE, if it is a SNIFFED- GOOSE it depends on the value it had when the message was captured.

By choosing "Keep current setting" no change is done on the value of the test service parameter of the published GOOSE messages.

It is also possible to set the test service parameter individually for each published GOOSE message, and this can be done directly from the "MyGOOSE" tab, see following figure.

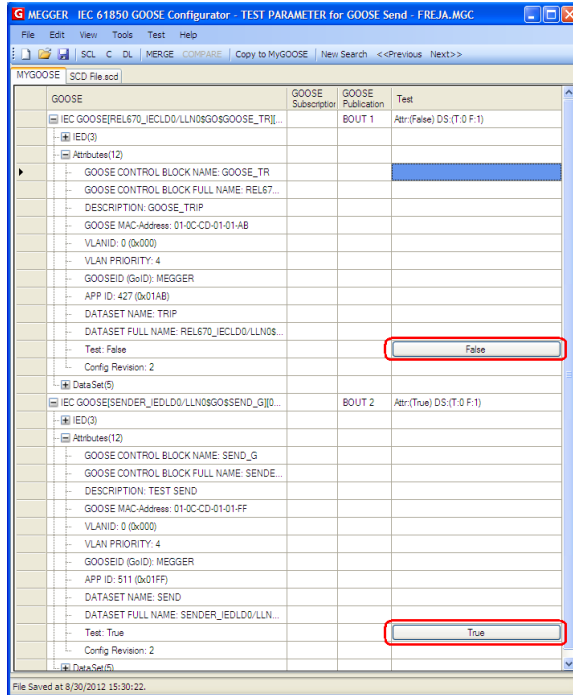

### 3.15.7.4 Manipulating the IEC-61850 test attribute in the quality parameter in the published GOOSE messages by the SMRT.

In the second half of the window (shown in "Manipulating the IEC-61850 test service parameter in pub) it is possible to manipulate the value of the test bit in the quality attribute of all GOOSE messages sent by the SMRT.

By choosing "Activate", all the test bits in the quality attributes are set to TRUE, no matter what their original value was, see the following figure.

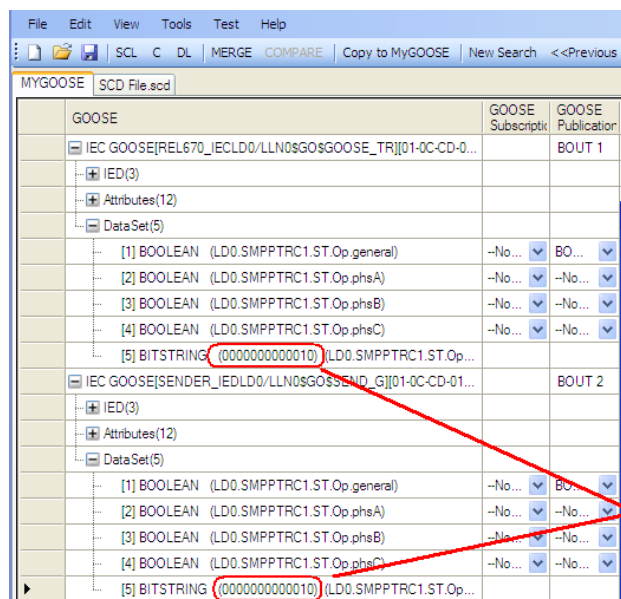

By choosing "Deactivate", all the test quality bits are set to FALSE, no matter what their original state was.

By choosing "Reset" all the published GOOSE messages will have the test quality bits set according to the original value. If SCL-GOOSE it is FALSE, if it is a SNIFFED-GOOSE it depends on the value it had when the message was captured.

By choosing "Keep current setting" no change is done on the value of the test quality bits of the published GOOSE messages.

It is also possible to set the test quality bit individually for each published GOOSE message, and this can be done directly from the "MyGOOSE" tab, see the following figure.

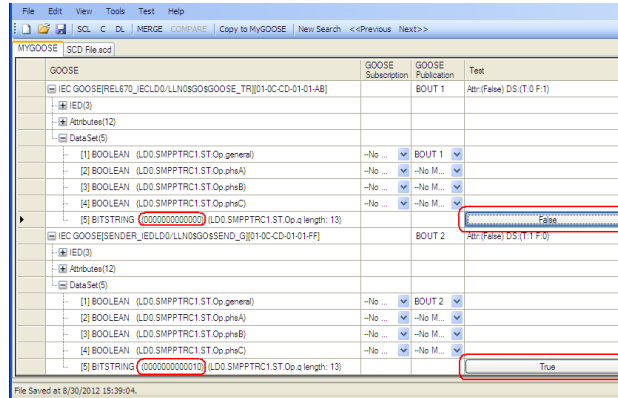

### 3.16 IEC 61850-9-2 Megger SVA Configurator (SVA)

The Megger Sampled Values Analyzer (SVA) Configurator software provides the capability to configure the SMRT test set (with the IEC 61850 Sampled Values hardware enabled) to publish three IEC 61850-9-2 LE data streams of 4 voltages and 4 currents per stream for testing or commissioning devices which require Sampled Values. In addition, the SVA software may be used to analyze sampled packet data on the IED Network.

#### 3.16.1 Testing Relays with Sampled Values

The Megger relay test system IEC 61850 Ethernet port is connected to the IEC 61850-9-2 process bus (or directly to the Ethernet port of the relay) and after configuration using the SVA software is programmed to publish either 50 Hz or 60 Hz IEC 61850-9-2 LE Sampled Values instead of analog values from the output terminals using RTMS. In some test cases, the Sampled Values is used in conjunction with IEC 61850 Megger GOOSE Configurator (MGC) software, where the mapped binary inputs and/or outputs are programmed to "subscribe to" and/or "publish" GOOSE messages (see Section 3.15).

#### 3.16.2 SVA Menu

The SVA tool bar contains File, Tools, and Help

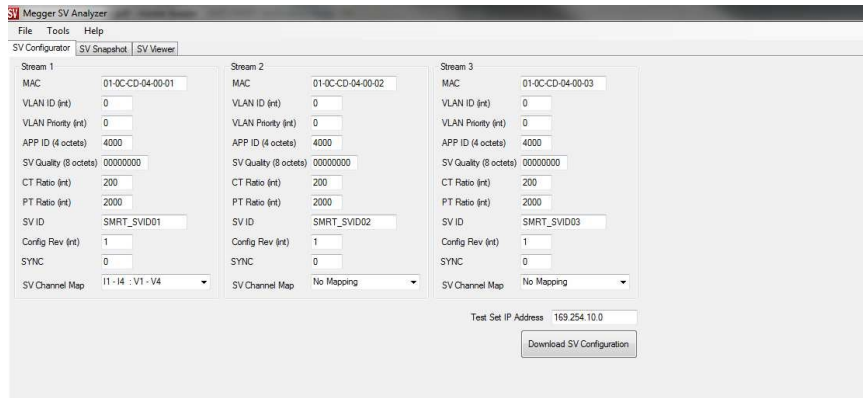

Figure 1 The SV Analyzer Start Up Screen

### 3.16.2.1 SVA File

The File option contains 5 selections:

#### 3.16.2.1.1 New File

This option allows users to select a new configuration page.

#### 3.16.2.1.2 Open File

Opens an \*.sva file.

#### 3.16.2.1.3 Save File

This option allows the user to save \*.sva file. This file contains all analog packet data values saved during the period, with Digital and Graphical values.

#### 3.16.2.1.4 Save As File

This is like save, except this allows users to create another \*.sva file with different name.

#### 3.16.2.1.5 Exit

Exit the File tab.

### 3.16.3 SV Configurator

The SV Configurator contains configuration settings for 3 Sampled Values Data Streams, where each stream provides 4 x V and 4 x I.

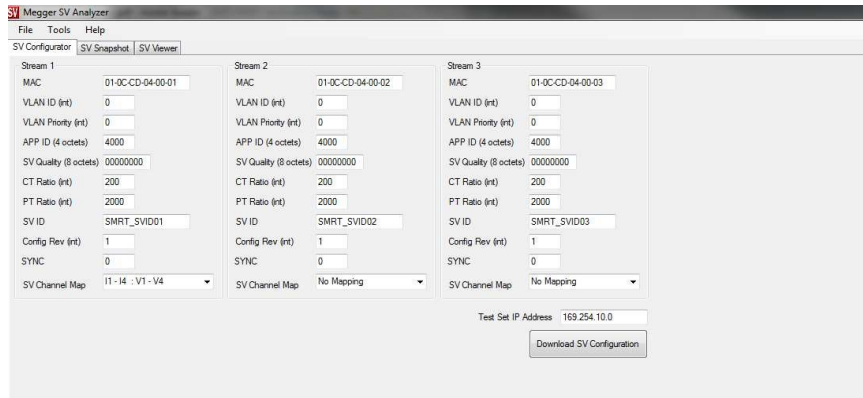

Figure 2 SV Configurator Screen

The following descriptions apply for all streams.

### 3.16.3.1 MAC

Enter MAC address definition for SV streams 1, 2 and 3.



Note that each data stream has a separate and unique MAC address, see figure above.

### 3.16.3.2 VLAN ID (int)

Allows user to define VLAN ID for streams 1, 2 and 3.

### 3.16.3.3 VLAN Priority (int)

Allows user to enter the VLAN priority ID for SV Streams 1, 2 and 3.

### 3.16.3.4 APP ID (4 octets)

Application security ID, defaults to 4000.

### 3.16.3.5 SV Quality (8 octets)

SV quality information.

### 3.16.3.6 CT Ratio (int)

Allows user to enter CT ratio of the device under test. This allows user to read digital values in terms of primary current. If user enters value as 1, they can read secondary values.

### 3.16.3.7 PT Ratio (int)

Allows user to PT ratio of the device under test. This allows user to read digital values in terms of primary current. If user enters value as 1, they can read secondary values.

### 3.16.3.8 SV ID)

Each data stream may have a user assigned ID. In the figure above, each data stream SV ID ends with the assigned number of 1 for stream1, 2 for stream 2, and 3 for stream 3.

### 3.16.3.9 Config Rev (int)

Configuration revision number.

### 3.16.3.10 SYNC

Method of SV Synchronization.

### 3.16.3.11 SV Channel Map

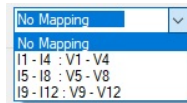

Figure 297 Mapping Sampled Values to Analog Channels

This option allows user to map analog channels for each data stream 1, 2 and/or 3. There are 4 options to select from. The following are descriptions of each option.

#### 3.16.3.11 No Mapping

No analog channels assigned to the stream.

#### 3.16.3.11.2 I1 – I4: V1 – V4

Analog current channels 1 through 4, and voltage channels 1 through 4 are assigned to this data stream.

#### 3.16.3.11.3 I5 – I8: V5 – V8

Analog current channels 5 through 8, and voltage channels 5 through 8 are assigned to this data stream.

#### 3.16.3.11.4 I9 – I12: V9 – V12

Analog current channels 9 through 12, and voltage channels 9 through 12 are assigned to this data stream.

### 3.16.3.12 Test Set IP Address

This allows the user to enter the unit IP or Network IP Address in the window provided.

### 3.16.3.13 Download SV Configuration

This button is located just below the Test Set IP Address window. Press this button to download the SV Configuration into the test set.

## 3.16.4 SV Snapshot

The SV Snapshot allows the user to capture SV stream data on the Network and display them as digital values.

### 3.16.4.1 Network Interface

The Network Interface pulldown window allows the user to select the Network interface to the test system. See the following example.

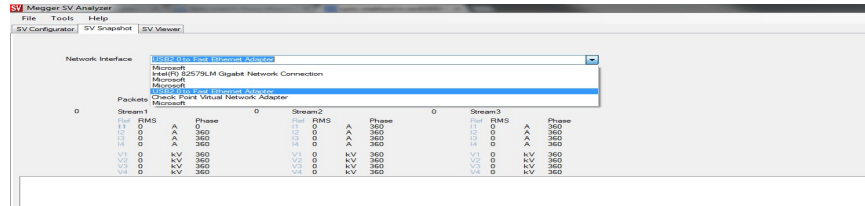

Figure 298 Selection of a Network Interface

### 3.16.4.2 Start button.

The Start button allows user to start capturing the SV stream data packets through the Network interface and display digital values as shown below.

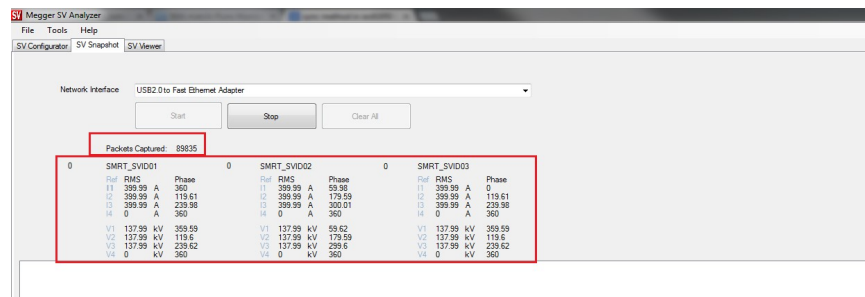

Figure 299 Example of Captured Sample Values Data

In the example above, current channel 3 is Phase reference. To change the reference Phase, click on the channel number. For example, to change the Phase reference to current channel 2 select SMRT\_SVID02, I2, and the Phase reference will change as shown in the following figure.

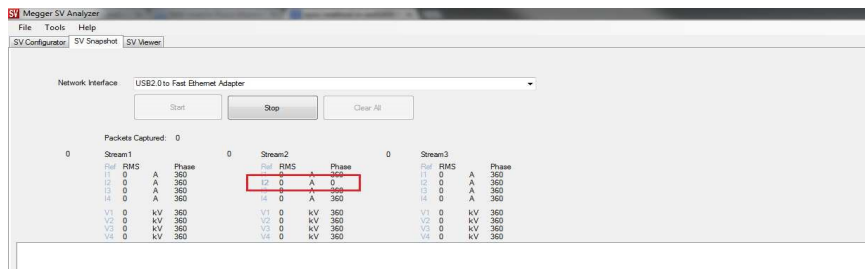

Figure 300 I2 Selected as Phase Reference

### 3.16.4.3 Stop button.

The Stop button allows user to stop the packet data capture mode and displays last SV stream data values. The last data packet capture is displayed along with the values, see the following figure.

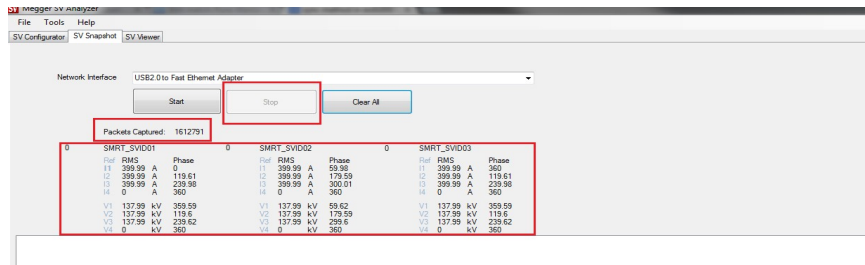

Figure 301 Last Captured Sampled Values Data Packet

### 3.16.4.4 Clear All button.

Pressing the Clear All button will clear all captured Sampled Values and set the data to zero.

### 3.16.5 SV Viewer

The SV Viewer allows the user to view all captured SV Stream data in a graphical format.

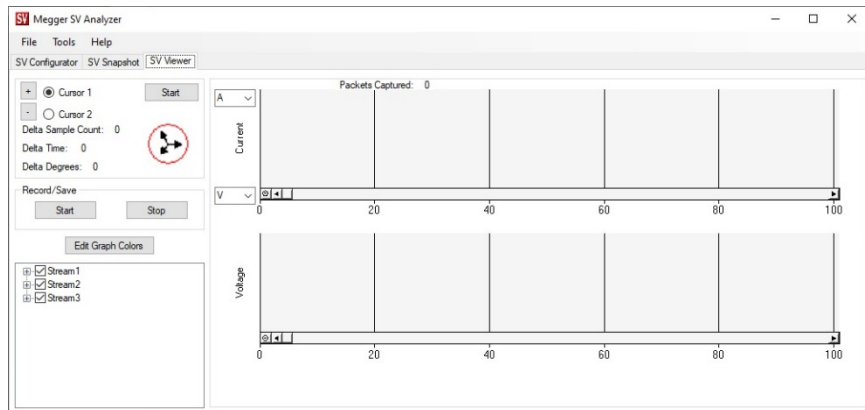

Figure 302 SV Viewer Startup Screen

### 3.16.5.1 Start button.

The Start button allows user to start capturing the SV stream data packets through the Network interface, and display the digital values as waveforms, see the following figure. Note that the Start button converts to a Stop button to allow the user to stop capturing data.

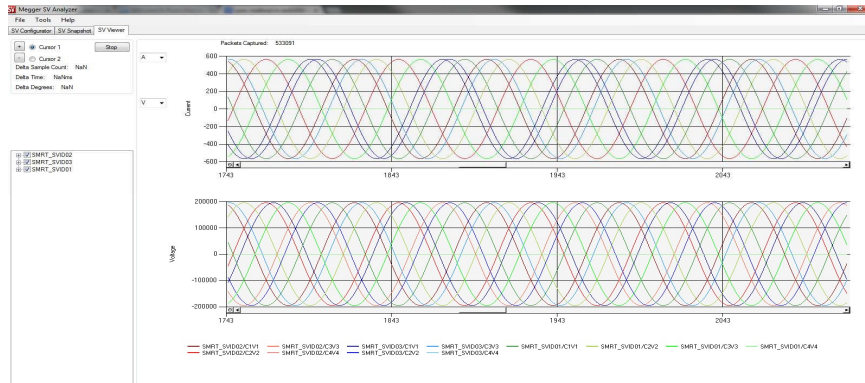

Figure 303 Captured Sampled Values as Waveforms

### 3.16.5.1.1 Enable/Disable Analog Channels

Click on the check box “✓” to enable/disable the channels for the displayed stream in the chart. Selecting all channels for SMRT\_SVID01, 02, 03, the user could expect to see something like the following figure.



Figure 304 Captured waveforms for all channels.

### 3.16.5.2 Current and Voltage Measurement Options

There are two pulldown windows located next to the graphic windows with default labels **A** (Amperes) and **V** (Volts). Click on the ▼ down arrow for Current and the user will see the following list of options.

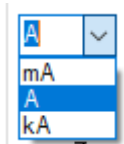

This allows the user to select the displayed values in the Y-axis of the current graph in mA, A, or kA. The Voltage is like the voltage graph, with the options of mV, V, or kV.

### 3.16.5.3 Viewing Data

After capturing a block of Sampled Values, the user may see something like the following figure, where 5,000 ms of data were captured.

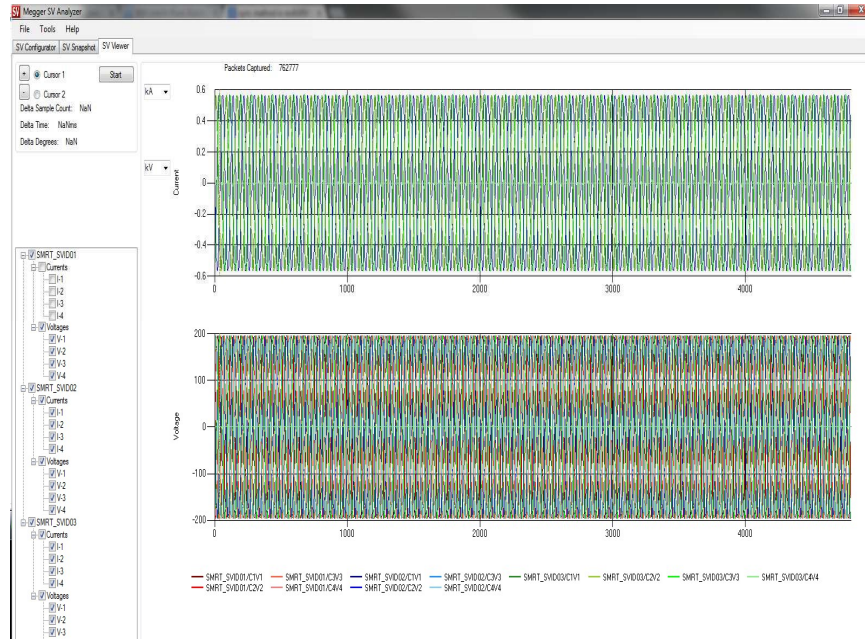

Figure 305 Example of Captured Sampled Values Data

If the user wishes to view the waveforms between 1000 ms to 2000 ms, then left click near 1000 ms on the line and hold the left mouse button moving the cursor across to the 2000 ms line. It would look something like the following figure.



Figure 306 Selecting from 1000 ms to 2000 ms for Viewing.

The result would be an expanded view of the selected waveform, see the following figure.



Figure 307 Expanded View of Captured Data

It should be noted in the figure above, Currents I1 to I4 for SMRT\_SVID01 were deselected by clicking off the Currents check box. Note the selected time is from 994 ms to 1994 ms. To return to the original data hold down the  button located in the lower left corner of the current and voltage graph.

To clear captured data, press the **Clear All** button in the **SV Snapshot** tab.

#### 4.0 Warranty Statement

Megger warrants the product is free of defects in material and workmanship for a period of one (1) year from date of shipment. This warranty is non-transferable. This warranty is limited and shall not apply to equipment that has damage, or cause of defect, due to accident, negligence, and improper operation, faulty installation by the purchaser, or improper service or repair by any person, company or corporation not authorized by Megger. Megger will, at its' option, either repair or replace those parts and/or materials it deems to be defective.

MEGGER will provide replacement of broken parts and provide service and repair as necessitated by normal use, unless specified otherwise within the warranty. MEGGER will, at its own option, either repair or replace those parts and / or materials that it deems to be defective. MEGGER will not be responsible for business loss or expenses incurred due to equipment failure.

**EXCLUSIONS:** The warranty does not cover (not all inclusive).

1. Replacement of consumable supplies.
2. Service necessitated by abuse, misuse, neglect, disassembly, or vandalism.
3. Unauthorized tampering/damage done to machine by someone other than an authorized MEGGER representative.
4. Damage due to faulty wired electrical supply, high or low voltage/ampereage, poor ground or interrupted electrical power.
5. Damage caused by casualties such as fire, flood, lightening, earthquake or other natural causes.

6. Damage through use of supplies for parts other than those meeting MEGGER specifications for the equipment.
7. Damage caused by transporting of the equipment, routine cleaning, etc.

The warranty is in lieu of all other warranties either expressed or implied on the part of Megger, and in no event shall Megger be liable for the consequential damages due to the breach thereof.

## 5.0 Service Data

### 5.1 Preventive Maintenance

The unit utilizes surface mount technology (SMT) and other components which require little or no service except for routine cleaning, etc. The unit should be serviced in a clean atmosphere away from energized electrical circuits.

#### 5.1.1 Examine the unit every six months for:

Dust and Dirt	To clean the unit, never use spray liquids or industrial cleaners. Some cleaning solvents can damage electrical components and should never be used. Use a lightly damp cloth (not dripping wet) to wipe off the unit. Remove dust with dry, low pressure, compressed air.
Moisture	Remove moisture as much as possible by putting the test set in a warm, dry environment.

#### 5.1.2 Upgrading RTMS on the STVI

##### Upgrade via Megger Website

To download the latest version of RTMS from the Megger website,

1. Get the serial number of your unit.
2. Go to [www.Megger.com](http://www.Megger.com)
3. Go to **Products/Relay and system testing/Relay Software.**
4. Click on the picture of **RTMS.**
5. There will be two versions of the software available on the Megger website, one is for installation on a PC and the other is for installation on STVI units, stand-alone or on display units. For the STVI unit, go to the **Onboard Install** and press on the  **Download** button. The software will be downloaded onto your PC as a zip file. Unzip the file, **Select All** files, and **Copy** to a USB memory stick, or create a file on your PC for storage to unzip or extract to a file.

##### How To Download RTMS onto the STVI using a USB Memory Stick.

1. With the STVI powered up, insert the USB memory stick into the USB port on top of the STVI.
2. Press the "System Configuration" button.
3. Press the "Update Firmware" button.
4. A pop-up window will appear asking whether you want to perform a "SMRT Firmware" or "STVI Firmware" update, select "STVI Firmware."
5. A pop-up window will appear stating that "PowerDB has found a USB drive with a software update," "Would you like to update now." Select the green check mark to start the installation or the red cross to abort.
6. If the green check mark was selected the installation will start.

7. When the installation is complete, remove the USB memory stick and connect to the SMRT unit in the connection box.
  8. When the Home screen appears, press the “Configuration” button, then press the “Display Versions” button and verify that the version installed is the same as what was downloaded from the Megger website.
- Note: Some older STVI USB ports do not support memory sticks larger than 1 Gb. If the Windows “Removable Disk (E)” Explorer screen appears, press the Cancel button, and then go to the STVI Configuration Screen and press the Update Firmware button.

### 5.1.3 Updating the SMRT Firmware

#### Updating Firmware via Megger Website

To download the latest SMRT firmware from the Megger website,

1. Get the serial number of your unit.
2. Go to [www.Megger.com](http://www.Megger.com)
3. Go to **Products/Relay and system testing/All Relay and system testing**.
4. Click on the picture of the **SMRT** model that you want to upgrade.
5. There will be two versions of the Firmware available on the Megger website, one is for 50 Hz applications and one for 60 Hz applications.
6. Select the Firmware version required by pressing on the  **Download** button. The Firmware will be downloaded onto your PC as a zip file. Unzip the file, and **Copy** to a USB memory stick, or create a folder on your PC for storage to unzip or extract to a file.

#### Firmware upgrade using a USB Memory Stick.

1. With the SMRT and STVI powered up, insert the USB memory stick into the USB port on top of the STVI.
2. Press the “**System Configuration**” button.
3. Press the “**Update Firmware**” button.
4. A pop-up window will appear asking whether you want to perform a “SMRT Firmware” or “STVI Firmware” update, select “SMRT Firmware.”
5. In the next window the user will see a message in the top part of the screen saying, “Discovering Instruments.”
6. A pop-up window stating that “Firmware update will take 2 – 15 minutes. Please do not abort process.”
7. The Firmware update will run through its process with some information messages appearing on the screen and then indicating the process in “percent complete.”
8. When the Firmware update is complete a message saying, “Please reboot Instrument when clicking.”
9. After rebooting the SMRT and when the Home screen appears, press the “System Configuration” button, then press the “Display Versions” button and verify that the Firmware version installed is the same as what was downloaded from the Megger website.

#### Firmware upgrade using a PC and RTMS.

1. If using the PC version of RTMS, the process to upgrade firmware is like the STVI upgrade process.
2. With RTMS on a PC connect to the SMRT to be upgraded.
3. Press the “**System Configuration**” button.
4. Press the “**Update Firmware**” button.

5. Upon clicking on the Update Firmware button, the familiar Windows *Open File* browser dialog box will appear. Using the *Look In* pull-down menu, navigate to where the new firmware was downloaded onto the PC.
6. Click on and open the file SMRT\_Firmware\_#.###x2\_#0Hz.ldr (SMRT Loader).
7. In the next window the user will see a message in the top part of the screen saying, "Discovering Instruments."
8. A pop-up window stating that "Firmware update will take 2 – 15 minutes. Please do not abort process."
9. The Firmware update will run through its process with some information messages appearing on the screen and then indicating the process in "percent complete."
10. When the Firmware update is complete a message saying, "Please reboot Instrument when clicking."
11. After rebooting the SMRT and connecting to the unit that was upgraded, when the Home screen appears, press the "System Configuration" button, then press the "Display Versions" button and verify that the Firmware version installed is the same as what was downloaded from the Megger website.

## 5.2 Service and Repair

If the unit is still within the original warranty period, or limited warranty period following factory servicing, **the factory must be contacted before attempting any repairs or the warranty will be void.**

Megger operate fully traceable calibration and repair facilities, ensuring your instrument continues to provide the high standard of performance and workmanship you expect. These facilities are complemented by a worldwide network of approved repair and calibration companies which offer excellent in-service care for your Megger products.

 **NOTE:** Under no circumstance should any unqualified person take the STVI or SMRT apart as this could damage sensitive parts and void the warranty.

### 5.2.1.1 Power Input

Input voltage affects the whole unit, including the 48 VDC to the STVI from the PoE port, and may or may not cause permanent damage if voltage is incorrect. These problems can often be corrected by simply using a quality source of input power. See unit front panel for input voltage rating.

Some symptoms are as follows:

1. Low voltage: Erratic operation, no display, or a dim display.
2. High voltage: Circuit breaker operation on SMRT unit, power supply failure.
  - a. For SMRT1 units, the STVI uses the PoE power supply. It has an LED that lights up under normal operation. If not lit, then the PoE power supply has failed and needs to be replaced, PN: 90001-736.
  - b. For SMRT33/43/36/46/410, the internal power supply needs to be repaired or replaced, contact the factory for further instructions.

### 5.2.1.2 Input Power Cord

Depending on the end destination country, the power cord can come with a NEMA 5-15 male connector, a CEE 7/7 Schuko two prong connector, a UK power cord, or with International Color Coded pig-tail wires (light blue, brown and green with yellow stripe) with the insulation jacket stripped ready for installation of the appropriate male connector. This applies to all SMRT's, SMRT1/1D/33/43/36/36D/46/46D/410/410D.

Model SMRT1 10NXXXA~~XXX~~ comes with a North American power cord (part number 620000).

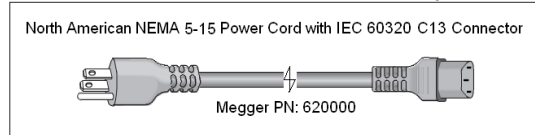

Model SMRT1 10NXXXE~~XXX~~ comes with a Continental Europe power cord (part number 50425).

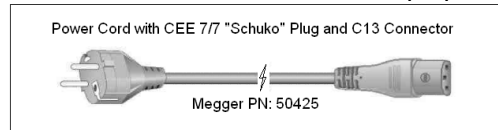

Model SMRT1 10NXXXI~~XXX~~ comes with an International Color Code power cord. The cord, part number 15065, is ready for wiring to the appropriate plug (depending on country). The following colors apply, Brown = Line, Blue = Neutral and Green/Yellow = Ground.

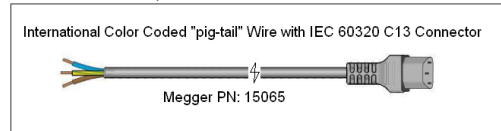

Model SMRT1 10NXXXU~~XXX~~ comes with a UK power cord (part number 90002-989).

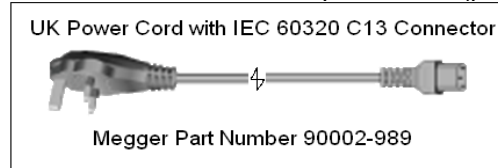

### 5.2.1.3 Ethernet Cable

Basic troubleshooting of the Ethernet communication cable as follows,

1. No power: Check power source and line cord. If the SMRT unit powers up, but the STVI display does light up, check the cable, and cable connectors. Typical problem is usually a broken conductor or cracked cable connector. Replace cable to see if this resolves issue.
2. Erratic Manual Control/Missing Channels on STVI Display
  - A. Communication cable is not properly connected, thus cannot receive proper commands.
  - B. Internal problem with communications inside the SMRT unit, see SMRT33/43/36/46, contact the factory for further instructions.

 Contact the factory for a Repair Authorization Number and return instructions if service is required. A Repair Authorization (RA) number will be assigned for proper handling of the unit when it arrives at the factory. Any non-warranty repair cost incurred for the repair or replacement of parts and/or materials shall be the responsibility of the purchaser.

Provide the factory with model number, Unit serial number, nature of the problem or service required, return address, your name, and how to contact you should the factory need to discuss the service request.

You may need to provide a purchase order number, cost limit, billing, and return shipping instructions. If an estimate is requested, provide the name, and contact information.

## 6.0 **Preparation for Reshipment**

 Save the original shipping container for future use. The shipping container is designed to withstand the rigors of shipping via a common commercial carrier.

Pack the equipment appropriately to prevent damage during shipment. If a reusable container is utilized, the unit will be returned to the same shipping container if it is in suitable condition.

Add the Return Authorization Number to the address label of the shipping container for proper identification and quicker handling.

- ▣ NOTE: Ship the equipment without nonessential items such as test leads, etc. These items are not needed by the factory to perform service.

# Megger<sup>®</sup>

## Addendum A



\*Standard enclosure model shown

## Model SMRT1 Megger Single Phase Relay Tester

## 1.0 Operation

The unit's design is a "modular" concept. All inputs and outputs are clearly marked and logically grouped so continual reference to the instruction manual should not be necessary once the operator is acquainted with the test system.

### 1.1 General Description

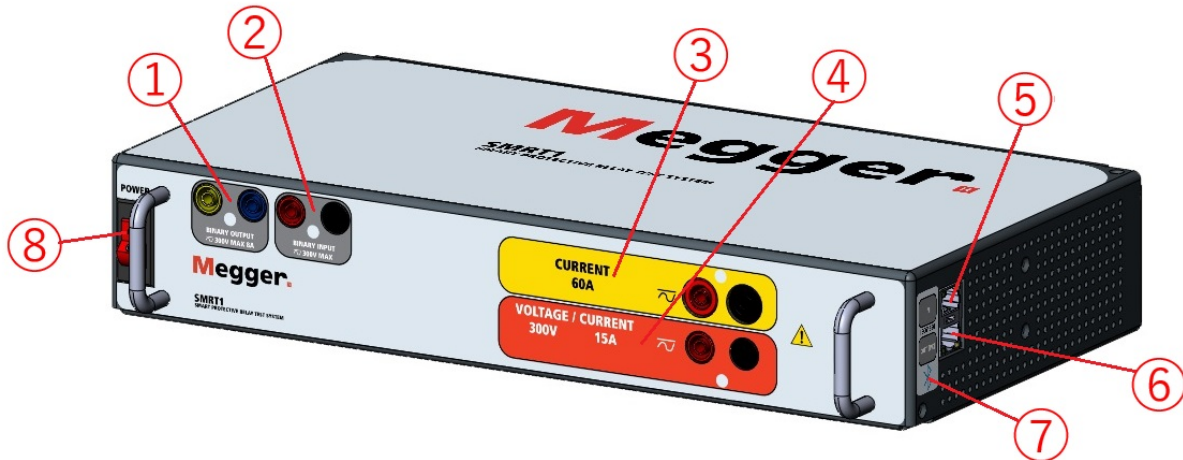

Figure 308 SMRT1 (Standard unit pictured)

#### 1.1.1 Front Panel

1. **Binary Output** ① – the Binary Output can be configured as Normally Open or Normally Closed contacts providing logic to the device under test. The Binary Output can switch up to 300 VAC or 250 VDC with 8 A continuous. The programmable wait duration is from 1 ms to 10,000 ms.
2. **Binary Input** ② –The Binary Input will accept a voltage range of 5 to 300 VAC, or 5 to 250 VDC, or dry Normally Open/Normally Closed contacts. The binary input voltage threshold is programmable from 2 to 150 V AC/DC.
3. **Current Channel Output** ③ – For more details on the VIGEN output capabilities see section 1.4.
4. **Voltage Channel Output** ④ – For more details on the VIGEN output capabilities see section 1.4.
5. **PC/IN** ⑤ Ethernet Port is a 10/100BaseTX port and is the primary PC connection port. This port supports MDI/MDI-X auto crossover configuration, which means both standard and "crossover" Ethernet cables may be used. This port provides the optimal method for downloading EMTP files, DFR streaming, and updating the unit's firmware as required. The SMRT comes standard with a crossover cable. This port may also be used for multiple unit

operation, the unit providing the 61850/OUT link is providing the primary phase reference to all units “downstream”.

6. **61850/OUT** ⑥ Ethernet Port is a 10/100BaseTX port and is primarily used to interconnect multiple SMRT units together for synchronous multi-unit operation. With the PC connected to the PC/ IN Port, the SMRT1 61850 / OUT port may be connected to another SMRT unit PC/IN port “downstream” providing phase synchronization through the Ethernet port. This port may also be used to provide access to the substation IEC 61850 network to receive and send GOSSE messages.
7. **Bluetooth** wireless port ⑦ – this port is optional and provides a wireless interface control with a PC. It also provides isolation between the IEC 61850 bus and the user PC.
8. **POWER ON/OFF Switch** ⑧ – used to switch unit on and off. The switch illuminates when power is on.

### 1.1.2 Side Panel:

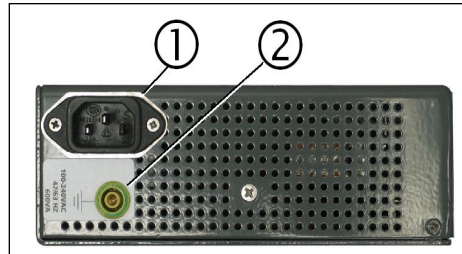

Figure 309 SMRT1 Power Input Panel

1. **Incoming Power/Line Cord** ① – the input line cord, ground terminal, are mounted on the side panel of the test set.

#### Input Line Cord



The test set is equipped with a line cord, which connects to the male connector on the side panel. Verify the input voltage before connecting the line cord to the power source.

**NOTE:** The unit can be powered from an input source with a rating of 100 VAC to 240 VAC, 50/60 Hz. The unit automatically adjusts to the available power if it is within the specified range.

2. **Earth Ground Jack** ② – use this terminal to connect chassis ground to earth ground.



A chassis ground (earth) point on the front panel is provided as an additional safety ground.

### 1.1.3 Rack Mount Enclosure Rear Panel:



Figure 310 SMRT1 Rack Mount Back Panel Power Input

1. **Incoming Power/Line Cord** – the input line cord, ground terminal, are mounted on the back panel of the test set.

#### Input Line Cord



The test set is equipped with a line cord; see the accessory kit, which connects to the male plug on the back panel. Verify the input voltage before connecting the line cord to the power source.

**NOTE:** The unit can be powered from an input source with a rating of 100 VAC to 240 VAC. The unit automatically adjusts to the available power if it is within the specified range.

2. **Earth Ground Jack** – use this terminal to connect chassis ground to earth ground.



A chassis ground (earth) point on the back panel is provided as an additional safety ground.



Figure 311 SMRT1 Rack Mount Back Panel Signal and Communication Ports

1. **IN** Ethernet Port is a 10/100BaseTX port and is the primary PC connection port. This port supports MDI/MDI-X auto crossover configuration, which means both standard and “crossover” Ethernet cables may be used. This port provides the optimal method for downloading EMTP files, DFR streaming, and updating the unit’s firmware as required. The SMRT comes standard with a crossover cable. This port may also be used for multiple unit operation, the unit providing the OUT link is providing the primary phase reference to all units “downstream.”
2. **OUT** Ethernet Port is a 10/100BaseTX port and is primarily used to interconnect multiple SMRT units together for synchronous multi-unit operation. With the PC connected to the IN Port, the SMRT1 OUT port may be connected to another SMRT unit IN port “downstream” providing phase synchronization through the Ethernet port. This port may also be used to provide access to the substation IEC 61850 network to receive and send GOOSE messages.
3. **External Amplifier BNC Inputs** – There are two BNC connectors labeled I and V/I on the back panel. These connectors are used to amplify an external analog signal using the SMRT amplifiers. Application of  $\pm 10$  V Peak will provide Full Scale output (Range dependent) from the selected output.



**CAUTION:** DO NOT APPLY MORE THAN  $\pm 10$  V PEAK TO THE EXT INPUT TERMINALS. APPLICATION OF MORE THAN 10 VOLTS PEAK MAY DAMAGE THE AMPLIFIER.

The input voltage may be from 100 to 240 VAC, 50/60 Hz, 600 VA. The input is protected by an ON/OFF switch/circuit breaker.

### 1.2.1. Input Power Cord

Depending on the country, the power cord can come with a NEMA 5-15 male connector, a CEE 7/7 Schuko two prong connector, a UK power cord, or with International Color Coded pig-tail wires (light blue, brown and green with yellow stripe) with the insulation jacket stripped ready for installation of the appropriate male connector.

Model SMRT1 10NXXXAXXX comes with a North American power cord (part number 620000).

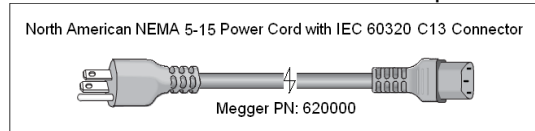

Model SMRT1 10NXXXEXXX comes with a Continental Europe power cord (part number 50425).

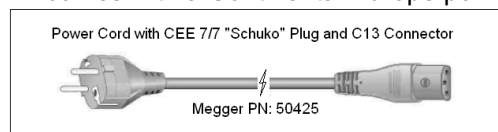

Model SMRT1 10NXXXIXXX comes with an International Color Code power cord. The cord, part number 15065, is ready for wiring to the appropriate plug (depending on country). The following colors apply, Brown = Line, Blue = Neutral and Green/Yellow = Ground.

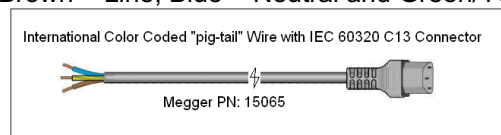

Model SMRT1 10NXXXUXXX comes with a UK power cord (part number 90002-989).

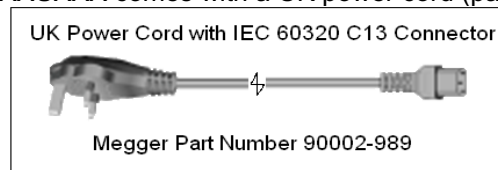

## 1.3 Voltage - Current Generators

Voltage and Current is noted by the red and yellow surrounding each output channel. The voltage channel is denoted by the red color. The current channel is denoted by the yellow color. All outputs are independent from sudden changes in mains voltage and frequency and are regulated so changes in load impedance do not affect the output. All SMRT1 amplifier outputs are isolated or floating.

### 1.3.1. Convertible Voltage/Current Amplifier

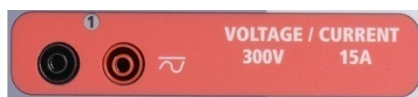

The SMRT PowerV™ voltage amplifier provides a flat power curve from 30 to 150 V in the 150V range to permit testing of high current applications such as panel testing.

Voltage Range	Power/Current (Max)
30.00 V	150 VA @ 5.0 A
150.00 V	150 VA Constant Output Power from 30 to 150 V
300.00 V	150 VA @ 0.5 A

**Voltage Amplifier in Current Mode :**

The voltage amplifier is convertible to a current source with the following output capability. Output power ratings are specified in RMS values and peak power ratings.

Output Current	Power	Max V	Duty Cycle
5 A	150 VA (212 peak)	30.0 V RMS	Continuous
15 A	120 VA	8.0 V RMS	1.5 s or 90 cycles

The convertible channel in conjunction with the main current channel provides 2 currents for testing current differential relays one phase at a time.

 The voltage amplifier output is protected from short circuits and thermally protected against prolonged overloads. In case of a short circuit or a thermal overload, the amplifier will automatically turn off, and if the STVI is connected a message to the user will be displayed indicating which condition exists.

**1.3.2. Current Amplifier**



The SMRT current amplifier delivers maximum compliance voltage to the load constantly during the test, and range changing is done automatically, on-the-fly, under load. This ensures better test results, saves time by not having to turn the outputs off to change output taps or ranges, and unlike single range current amplifiers insures a higher compliance voltage at lower test currents. Constant power output in many cases eliminates the need to parallel or series current channels together to test high burden relays.

The following are typical output current and associated available compliance voltage values. The output current and power ratings are specified in AC RMS values and peak power ratings. Specified duty cycles are based upon typical room temperature.

Output Current	Power	Max V/Duty Cycle
1 A	15 VA	15.0 V RMS Continuous
4 A	200 VA (282 peak)	50.0 V RMS Continuous
15 A	200 VA (282 peak)	13.4 V RMS Continuous
32 A	200 VA (282 peak)	6.25 V RMS Continuous
60 A	319 VA (424 peak)	5.00 V RMS 1.5 s or 90 cycles
DC 200 W		

 The current amplifier output is protected from open circuits and thermally protected against prolonged overloads. In case of an open circuit or a thermal overload, the amplifier will automatically turn off, and if the STVI is connected a message to the user will be displayed indicating which condition exists.

## 1.4 Binary Input and Output



Figure 312 SMRT1 Binary Input and Output

The SMRT1 Binary Input and Output are clearly marked and logically grouped. The Binary Input is used to monitor relay trip contacts for performing pickup and dropout tests as well as for performing timing functions. The Binary Output is used to simulate normally open/normally closed contacts for testing breaker failure schemes, or similar power system operations. In addition, they may also be used to switch AC/DC voltages and currents.

### 1.4.1 Binary Input

The binary input is specifically designed to measure high speed operation of electro-mechanical, solid-state, and microprocessor-based protection relays. The binary Input defaults to Monitor Mode, Contact change of state, latched OFF. When using RTMS to change a binary input from Contact change of state to Voltage Applied/Removed click on or touch the Input Type window and a sine wave will appear where the Contact icon was indicating. The input is now set for voltage sensing. To change the binary input from Monitor mode to Timer Mode, click on or touch the Use as Monitor button and the display window will change to show Use as Trip, Latched, meaning the binary input is now set to stop the timer upon sensing the first contact closure (if the Input Type is set for contact) or upon sensing voltage if the Input Type is set to Voltage Sensing.

#### 1.4.1.1 Start, Stop, and Monitor Gate

In the SMRT1 the independent, programmable gate circuit permits simple selection of the desired mode for timing or contact monitoring operation.

To monitor operation of the contacts or trip SCR in the device under test, a light is provided for the gate. The gate circuit is isolated for voltage-sensing and can monitor solid-state logic signals. The light will illuminate once contacts close or voltage is applied to the gate.

##### 1.4.1.1.1 Dry Contacts Open

Timer stops or a continuity indicator goes out at the opening of normally closed contacts, or when conduction through a semiconductor device, such as a triac or a transistor, is interrupted.

##### 1.4.1.1.2 Dry Contacts Close

Timer stops or a continuity indicator glows at the closing of the normally open contacts, or upon conduction through a semiconductor device such as a triac or a transistor.

#### 1.4.1.1.3 Application or Removal of AC or DC voltage

The continuity indicator will glow (application) or darkens (removal) upon the application or removal of either an AC or DC voltage. A higher threshold voltage helps to eliminate false triggers due to a noisy source. Lower thresholds allow stopping the timer from TTL voltage signals. The allowable voltage applied is 5 to 300 VAC or 5 to 300 VDC, current limiting resistors provide protection. Binary Inputs 1 & 2 have programmable voltage thresholds from 2 to 150 V AC/DC.

1.4.1.1.4 The Timer can be started when turning on any selected generators.

1.4.1.1.5 The Timer can be started simultaneously with a change in Frequency, Phase Angle, or Amplitude. Also, it can be started simultaneously with a Voltage or Current waveform step.

#### 1.4.2 Binary Output

Binary Output is rated for 300 V at 8 A and a maximum of 2000 VA breaking capacity (80 Watt DC), with a response time of less than 10ms. The Binary Output can be configured as normally open or normally closed contacts providing logic to the device under test. The programmable wait duration is from one ms to 10,000 ms.

## 2.0 SETUP

### 2.1 Unpack System

Unpack the unit and check for evidence of any shipping damage. If there is any visual damage, immediately notify the freight carrier to make a damage claim and notify Megger of the damage.



#### **CAUTION:**

**Potentially lethal voltages may be present on the output terminals. It is highly recommended the operator read the user manual thoroughly and understand the test set operation prior to turning power on.**

#### 2.1.1 Initial Start Up

1. With the Ethernet cable supplied with the unit connect the **IN** Ethernet Port on the SMRT unit to the Ethernet port on the PC Ethernet port. If using the STVI-2, connect the SMRT1 **IN** port to the PoE power supply **Data In** port, and connect the **Data & Power Out** port to the STVI Ethernet port.
2. Before connecting power to the unit, make sure the POWER ON/OFF Switch is in the OFF position (0). Plug the unit line cord into an appropriate power source and turn the POWER ON/OFF Switch to ON (I). As the SMRT unit goes through its power up sequence, in about a minute the STVI power up screen will appear, then the manual start up screen will appear.

### 2.2 Communication Ports

There are two Ethernet communication ports and an optional Bluetooth wireless port available on the Standard enclosure SMRT1. The Standard enclosure SMRT1 ports are located on the right side of the enclosure. For the Rack Mount unit, the ports are located on the back panel. The Rack Mount version does not have the optional Bluetooth wireless port. To connect with Bluetooth, the activation code is, 0000 (that is four zeros).

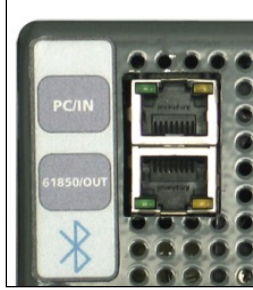



Figure 313 SMRT1 Communication Ports

### 2.2.1 PC/IN Ethernet Port

PC/IN Ethernet Port is a 10/100BaseTX port and is the primary PC connection port. This port supports MDI/MDI-X auto crossover configuration, which means both standard and “crossover” Ethernet cables may be used. This port provides the optimal method for downloading EMTP files, DFR streaming, and updating the unit’s firmware as required. This port may also be used for multiple unit operation, the unit providing the **61850/OUT** link is providing the primary phase reference to all units “downstream”. In addition, the port may also be used to talk to the SMRT1 unit via a Network.

#### 2.2.1.1 Setting SMRT IP Address for Operation with a PC

With the Ethernet cable supplied with the unit, connect the **PC/IN** Ethernet Port on the SMRT1 unit to the PC Ethernet port. Turn the test set on. As the SMRT unit goes through its power up sequence, in less than a minute the Binary Output LED will flash a few times (see more information below). When the flashing has stopped the unit is ready. Using the PC version of RTMS it will auto-detect the SMRT unit connected to the PC. Once it auto-detects the unit, and determines the configuration of the SMRT unit connected, the Manual screen will appear. The unit might not auto detect due to the firewall settings. In this case the firewall can be turned off or you can enter the IP address directly using the PowerDB

instrument configuration screen by clicking on the Instrument Setup icon on the PowerDB tool bar . From the Instrument Configuration Screen, shown in the following figure, click off the check mark in the Auto Discover Unit box.

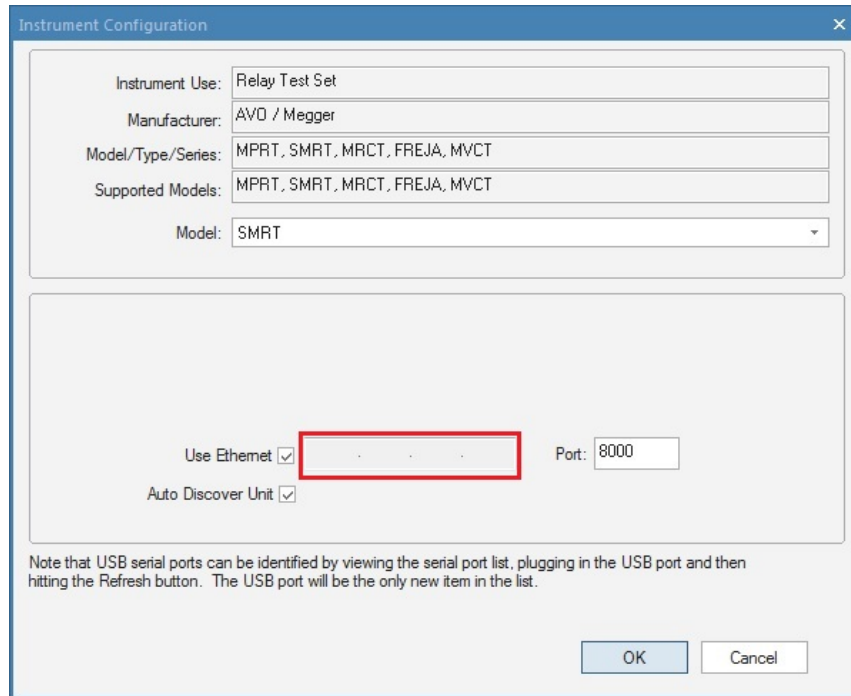

Figure 314 PowerDB Instrument Setup Screen

With the Auto Discover Unit box checked RTMS should find the unit. If not, the IP address can be entered in the box highlighted in the figure above. Also note that the IP address is also printed on the unit nameplate sticker. If the unit is on a network with a DHCP server, the user must use the Auto Discovery mode.

#### 2.2.1.2 Setting SMRT IP Address for Networks



The SMRT1 may be controlled over a network. This provides remote control of the SMRT1 over any distance allowing one PC to control at least two or three units simultaneously, such as in end to end testing.



Connecting the SMRT1 to a Local Area Network or a Wide Area Network could permit unauthorized operation of the unit.

Through the IN Ethernet port, the SMRT1 integrates into a network just like a PC or server. To use this feature requires the user to setup the IP configuration of the SMRT1 for their LAN. Note that the SMRT1 when turned on will automatically search for and acquire a network address if connected to a network. If it fails to automatically acquire an address check to make sure you are properly connected using a **standard** Ethernet cable. **Do not** use the cross over Ethernet cable supplied with the test set (a cross over cable is designed for use from your PC to the test set, not to a network). If the unit still fails to acquire an address, then there may be other issues. This will require assistance from your company's information management department.

#### 2.2.2 61850/OUT Ethernet Port

The OUT Ethernet Port is a 10/100BaseTX port and is used when interconnecting multiple SMRT units together. With the unit IN port connected to a PC, the OUT port would be connected to the “downstream”

SMRT unit IN port, providing phase reference to all downstream SMRT units. Note that another SMRT1 IN port could be connected to the OUT port of the upstream SMRT unit, and so on thus creating a multi-phase test system. This port also provides access to the substation IEC 61850 network (when enabled) to receive and send GOOSE messages. The SMRT1 with the IEC 61850 option enabled provides selectable priority, VLAN-ID, and meets the IEC 61850-5 standard Type 1A, Class P 2/3, for high speed trip and reclose simulations.

### 2.2.2.1 IEC 61850 Operations

For IEC 61850 testing connect the IEC61850/OUT port to the substation bus or to the relay under test to receive and send GOOSE messages. When used with the Megger GOOSE Configurator in the RTMS, the SMRT1 can provide high speed testing of IEC 61850 relays and substations by subscribing to GOOSE messages and mapping to the binary input. In addition, it can simulate system conditions such as circuit breaker operation by publishing GOOSE messages mapped to the SMRT1 binary output. With the PC connected to the SMRT1 IN port, and running Megger GOOSE Configurator software (MGC), the operator can “sniff” the substation network. If a secure port is desired, with the optional Bluetooth wireless port, use the SMRT1 to “sniff” the network through the IEC61850/OUT port.

## 3.0 Current Sources

### 3.1 Parallel Operation

Each SMRT current amplifier can provide 32 A continuous, and up to 60 A for 1.5 s or ninety cycles for testing instantaneous trip elements. When more than 32 A single phase is required for long durations, or 60 A for testing instantaneous elements, two or three current channels may be connected in parallel to provide 60 or 90 A continuous, and up to 120 or 180 A for short durations.

To parallel the current channels of multiple SMRT1 units, perform the following:

If using the sleeved pair of current test leads (part number 2001-394), connect each current channel to the relay under test (both red and black terminals to the load). Each Megger test lead is rated 32 A continuous. If using test leads other than those supplied by Megger, ensure that the wire has sufficient size to carry the test current. See the following figure.

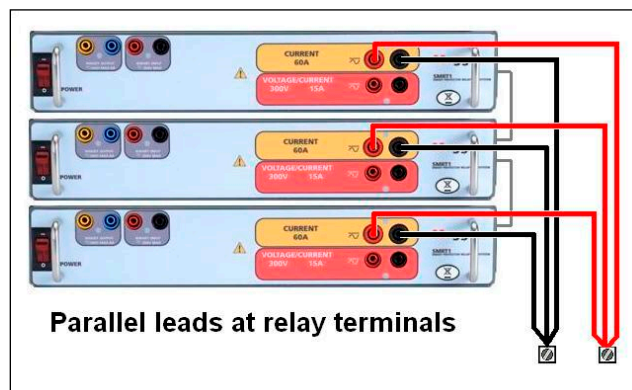

Figure 315 Parallel of Three SMRT1 Current Outputs

### 3.1.1 Manual Test Screen - Single Phase Up To 180 A

With three SMRT1 interconnected, go to the Configuration screen, and select the Operating Mode of **3 Voltages – 1 Current @ 180A**. When you return to the manual test screen there will be one current channel displayed, as shown in the following figure.

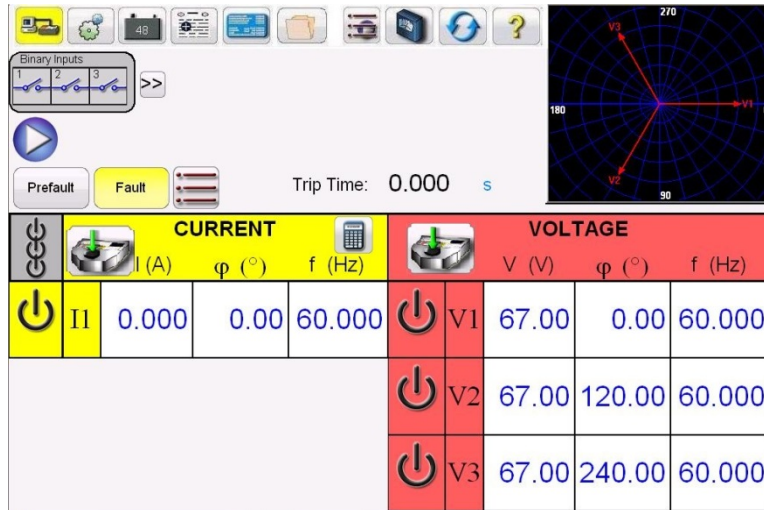

Figure 316 Manual Test Screen – Three SMRT1 Units in Single Phase Operation

The STVI will automatically set all three currents in phase with each other and divide the current equally between the three current amplifiers. When setting an output, simply enter the value of the desired output current. For example, for an output of 75 A, enter 75, while each current amplifier will be providing 25 A. The current can also be phase shifted. Simply enter the desired phase angle and all three currents will be phase shifted together.

If two current channels are used in parallel, connect the two current outputs to the load as shown in the following figure.

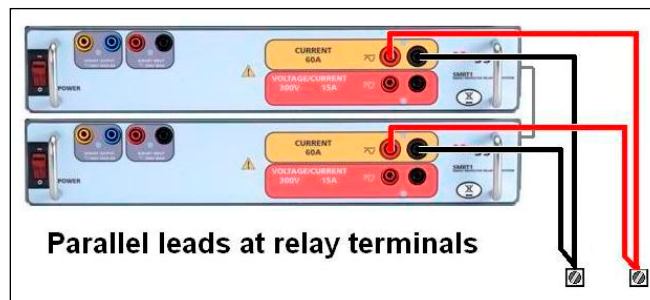



Figure 317 Two Currents in Parallel

Set each channel to one-half of the output requirement. Be sure and reset current channel #2 to 0 degrees so that it will be in-phase with current channel #1. With both current channels selected, turn output on by pressing or clicking on the ALL ON/OFF button. Always use the ALL ON/OFF button to turn both current channels on and off together. For manually ramping outputs, if using the PC version of

RTMS the  $\uparrow\downarrow$  buttons will be displayed. If using an STVI controller the Control Knob icon  will be displayed. Pressing either of these two will present the user with a window to select the desired level of

increment for manually ramping the outputs, the desired channel(s) to be ramped, and what is to be adjusted (amplitude, phase angle or frequency).

### 3.2 Currents in Series Operation

Two current channels may be connected in series to double the available compliance voltage. High impedance electromechanical ground (earth) overcurrent relays have always been difficult to test at high multiples of tap due to the winding impedance and saturation characteristics. The peak voltage required can exceed the maximum output voltage of one SMRT1 current output channel, depending on the required test current. By connecting two current outputs in series, the compliance voltage is doubled, providing higher test currents through the load. Connect the two current amplifiers in a “push-push” configuration as shown in the following figure.

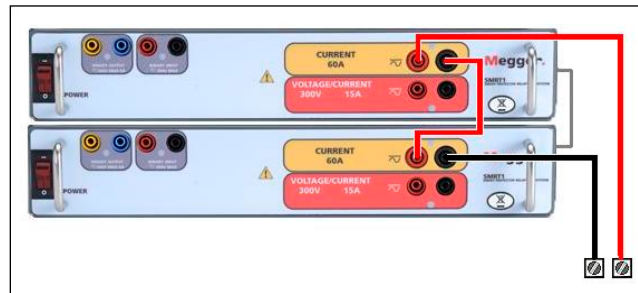



Figure 318 Series Two Currents

Using RTMS on the STVI or a PC set each of two current channels to the same test current magnitude, and phase angle. Select both current channels and turn output on by pressing or clicking on the ALL ON/OFF button. Always use the ALL ON/OFF button to turn both current channels on and off together. For manually ramping outputs, if using the PC version of RTMS the  $\updownarrow$  buttons will be displayed. If using an STVI controller the Control Knob icon  will be displayed. Pressing either of these two will present the user with a window to select the desired level of increment for manually ramping the outputs, the desired channel(s) to be ramped, and what is to be adjusted (amplitude, phase angle or frequency).

## 4.0 Voltage Sources

### 4.1 Outputs Summed Together

Two voltage channels may be used to sum the voltage outputs to obtain higher than rated voltage provided the load is ungrounded. Connect the load between the voltage channel posts, set  $V_1$  Phase to  $0^\circ$  and set  $V_2$  Phase to  $180^\circ$ . The voltage outputs will add so the total voltage is the sum of the two voltage amplitudes,  $V_1$  and  $V_2$  as can be seen in the picture below.

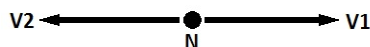

Connect the associated voltage channels black common returns together, when series operation is required (see the following figure). DO NOT attempt to series more than two voltage channels together since the test leads are rated up to maximum of 600 V.

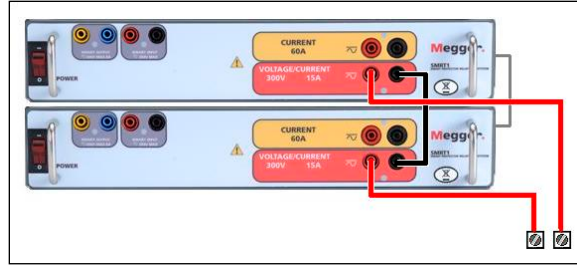

Figure 319 Series of Voltage Channels

## 4.2 3Ø, 3-Wire, Open-Delta, and T-Connection

### 4.2.1 Balanced Open Delta

Two methods of obtaining a three-phase, three-wire voltage source are available. The Open-Delta configuration is easier to use when a balanced three-phase source is required because the amplitude and phase relationship can be set directly. No calculations are necessary.

When using the Open-Delta configuration, it is suggested to use voltage channel #1, designated  $V_1$ , and voltage channel #2, designated  $V_2$ , while the COMMON binding post is designated  $V_g$ . With this arrangement, the magnitude and phase angle of the potentials can be easily calculated and set. For the balanced three-phase condition  $V_{1g}$  and  $V_{2g}$  are equal in magnitude and separated by an angle of  $60^\circ$ . This is done by setting the  $V_1$  and  $V_2$  potentials equal in magnitude, setting zero° on  $V_1$  and  $300^\circ$  ( $60^\circ$  leading assuming that the default phase rotation is set to  $360^\circ$  Lag) on  $V_2$ , see the following figure.

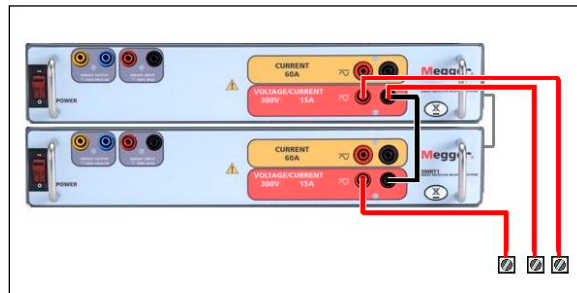

Figure 320 Three Phase Open Delta Connections

When using the Open-Delta Configuration to set up a phase-to-phase fault, calculations' using the Law of Cosines is required to calculate amplitude and phase relationships. (See discussion under T-Connection for simulating unbalanced, phase-to-phase faults without need for calculations.)

### 4.2.2 T Connection

The second method of obtaining a three-phase, three-wire voltage source is the so-called T-Connection. The method, shown in the following figure, is easier to use when obtaining an unbalanced, phase - to - phase fault simulation since it eliminates calculations. To reduce confusion when using the T-Connection, the voltage output #1 is designated  $V_a$  and its phase angle set at  $0^\circ$ , voltage output #2 is designated  $V_b$  and its phase angle set for  $180^\circ$ , and voltage output #3 is designated  $V_c$  and its phase angle is set for  $270^\circ$ . Any combination of balanced three phase faults or unbalanced phase-to-phase fault conditions can be easily simulated. The following figure indicates these phase relationships.

**!** NOTE: This method should not be used for low fault voltages, or used on solid state relays that may be sensitive to this type of connection (i.e., 5 V or less, or for testing ABB or Westinghouse type SKD relays).

#### 4.3 3Ø, 4-Wire, Y-Connection

A three-phase, four-wire potential system can be provided using three output modules. The vector relationships are referenced below. This Y-Connection has the advantage of being able to supply a higher line-to-line voltage ( $1.73 \times$  phase-to-neutral voltage). It is ideally suited for simulating phase-to-ground faults. Voltage channel #1 is designated as  $V_a$  with its phase relationship set for  $0^\circ$ . Voltage channel #2 is then designated as  $V_b$  and phase angle set for  $120^\circ$ . Finally, voltage channel #3 is designated  $V_c$  and phase angle set for  $240^\circ$  (for a 1-2-3 counterclockwise rotation).  $V_a$ ,  $V_b$  and  $V_c$  are connected to the voltage potential binding posts on the respective test sets.

If using the optional sleeved multi-lead voltage test leads (part number 2001-395), all the black return leads are interconnected together inside the sleeve so they will all share the return together. Therefore, only one return lead is provided on the relay connection side of the sleeved leads (like the connections in the following figure).

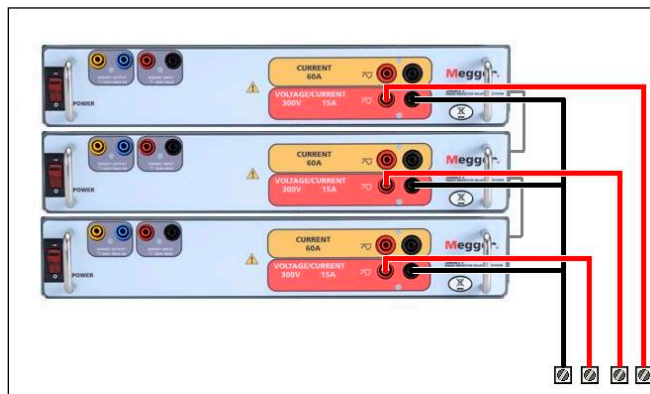

Figure 321 Three Phase Four Wire Voltage Test Connections

# Addendum B



## Model SMRT1D Megger Relay Tester

## 1.0 Operation

The unit's design is a "modular" concept. All inputs and outputs are clearly marked and logically grouped so continual reference to the instruction manual should not be necessary once the operator is acquainted with the test system.

### 1.1 General Description

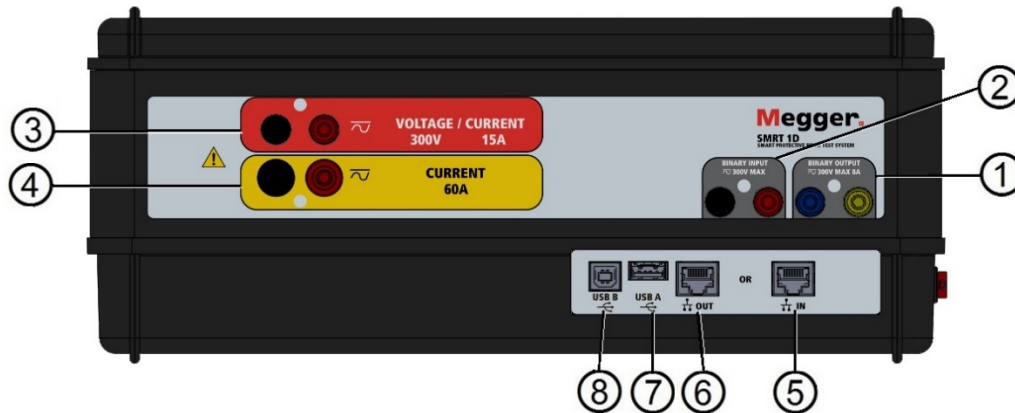

Figure 322 SMRT1D Top Panel

#### 1.1.1 Top Panel

1. **Binary Output** ① – the Binary Output can be configured as Normally Open or Normally Closed contacts providing logic to the device under test. The Binary Output can switch up to 300 VAC or 250 VDC with 8 A continuous. The programmable wait duration is from one ms to 10,000 ms.
2. **Binary Input** ② – The Binary Input will accept a voltage range of 5 to 300 VAC, or 5 to 250 VDC, or dry Normally Open/Normally Closed contacts. The binary input voltage threshold is programmable from 2 to 150 V AC/DC. For **GPS End-to-End synchronized relay testing** the **Binary Input** may relate to a remote trigger pulse from a GPS satellite receiver for external initiation, or the input of an **IRIG-B** signal (see use of **Wait IRIG-B** input using the RTMS Sequencer test). The Binary Inputs will accept a voltage range of 5 to 300 VAC, or 5 to 250 VDC, or dry Normally Open/Normally Closed contacts.
3. **Voltage Channel Output** ③ – For more details on the VIGEN output capabilities see section 1.4.
4. **Current Channel Output** ④ – For more details on the VIGEN output capabilities see section 1.4.
5. ⑤ **IN** Ethernet Port is a 10/100BaseTX port and is the primary PC connection port. This port supports MDI/MDI-X auto crossover configuration, which means both standard and “crossover” Ethernet cables may be used. This port provides the optimal method for downloading EMTP files, DFR streaming, and updating the unit’s firmware as required. This port may also be used for connecting to the IEC 61850 substation bus for use in testing IEC

61850 devices. For multiple unit operation, the unit providing the OUT link is providing the primary phase reference to all units “downstream.”

6. ⑥ **OUT** Ethernet Port is a 10/100BaseTX port and is primarily used to interconnect multiple SMRT units together for synchronous multi-unit operation. It is also used to provide access to the substation IEC 61850 network. For multiple unit operation, the unit providing the OUT link is providing the primary phase reference to all units “downstream.” With the PC connected to the PC Port, the SMRT and the PC share the same Ethernet network connection, and thus will not have secure isolation from each other. When testing IEC 61850 devices connect the PC to the ISOLATED Ethernet port to isolate the PC from the IEC 61850 substation bus.
7. ⑦ **USB** Interface – This USB Type A port is primarily used to update the firmware in the SMRT as well as update RTMS using a USB memory stick. It may also be used to download test results from the SMRT for download onto another PC with PowerDB software for storage or printing. In addition, the user can use a USB keyboard, as well as a mouse, in conjunction with the STVI. Keyboard and/or mouse are not provided with accessories.
8. ⑧ **USB** Interface - USB Interface requires a Type B “downstream” connector and is primarily used as a communication and control port when used with a PC and Megger software for automated relay testing.

#### 1.1.2 Front Panel:

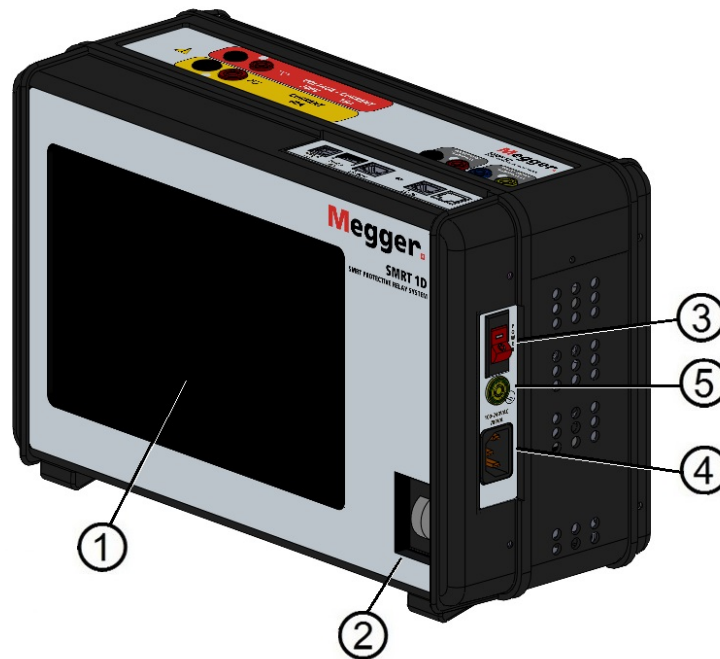

Figure 323 SMRT1D Front Panel

1. ① **TFT LCD Color Display** – this touch panel display provides high resolution and features Wide Viewing Angle Technology with high luminance for reading in direct sunlight.

2. ② **Control Knob**– this knob will adjust values once the box location of the value to be changed is selected.
3. ③ **POWER ON/OFF Switch** – used to switch unit on and off.
4. ④ **Incoming Power/ Line Cord** – the input line cord, ground terminal, are mounted on the right-side panel of the test set.
5. ⑤ **Earth Ground Jack**– use this terminal to connect chassis ground to earth ground.



A chassis ground (earth) point on the front panel is provided as an additional safety ground.

## 1.2 Input Power

The input voltage rating may be from 100 to 240 VAC,  $\pm 10\%$ , 50/60 Hz. The maximum input power is 1000 VA. The input is protected by a power ON/OFF switch/circuit breaker.

### 1.2.1. Input Power Cord

Depending on the country, the power cord can come with a NEMA 5-15 male connector, a CEE 7/7 Schuko two prong connector, with International Color Coded pig-tail wires (light blue, brown and green with yellow stripe) with the insulation jacket stripped ready for installation of the appropriate male connector, or with UK power cord.

Model SMRT1D 10NXXXAXXX comes with a North American power cord (part number 620000).

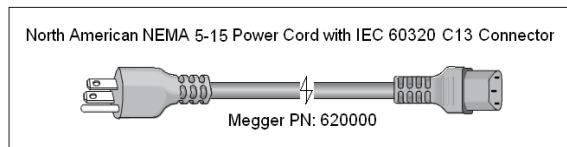

Model SMRT1D 10NXXXEXXX comes with a Continental Europe power cord (part number 50425).

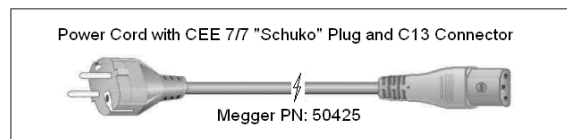

Model SMRT1D 10NXXXIXXX comes with an International Color Code power cord. The cord, part number 15065, is ready for wiring to the appropriate plug (depending on country). The following colors apply, Brown = Line, Blue = Neutral and Green/Yellow = Ground.

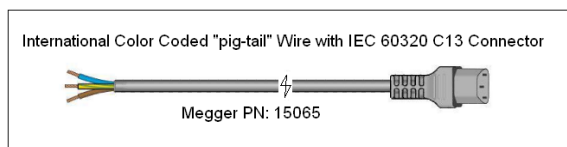

Model SMRT1D 10NXXXUXXX comes with a UK power cord (part number 90002-989).

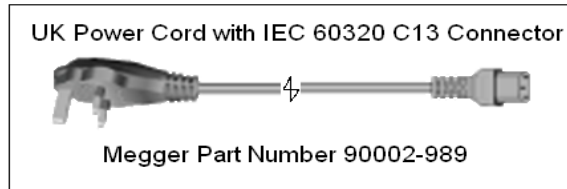

### 1.3 Voltage - Current Generator (VIGEN) Module

Voltages and Currents are noted by the red and yellow surrounding each output channel. Phases 1 and 2 voltage channels are denoted by the red color. Phases 1 and 2 current channels are denoted by the yellow color. All outputs are independent from sudden changes in mains voltage and frequency and are regulated so changes in load impedance do not affect the output. Standard amplifier outputs are isolated or floating.

#### 1.3.1 Convertible Voltage/Current Amplifier

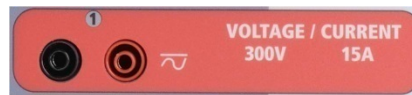

Figure 324 SMRT1D Voltage Channel

The SMRT PowerV™ voltage amplifier provides a flat power curve from 30 to 150 Volts in the 150V range to permit testing of high current applications such as panel testing.

Voltage Range	Power/Current (Max)
30.00 V	150 VA @ 5.0 A
150.00 V	150 VA Constant Output Power from 30 to 150 V
300.00 V	150 VA @ 0.5 A

Voltage Amplifier in Current Mode :

The SMRT1D voltage amplifier is convertible to a current source with the following output capability. Output power ratings are specified in RMS values and peak power ratings.

Output Current	Power	Max V	Duty Cycle
5 A	150 VA (212 peak)	30.0 V RMS	Continuous
15 A	120 VA	8.0 V RMS	1.5 s or 90 cycles

When the voltage generators are converted to current generators, they will change on the STVI display as current phases 4 and 5.

 The voltage amplifier output is protected from short circuits and thermally protected against prolonged overloads. In case of a short circuit or a thermal overload, the amplifier will automatically turn off, and a message to the user will be displayed indicating which condition exists.

### 1.3.2. Current Amplifier

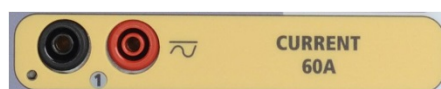



Figure 325 SMRT1D Current Channel

The SMRT current amplifier Constant Power Output feature delivers maximum compliance voltage to the load constantly during the test, and range changing is done automatically, on-the-fly, under load. This ensures better test results, saves time by not having to turn the outputs off to change output taps or ranges, and unlike single range current amplifiers insures a higher compliance voltage at lower test currents. Constant Power Output in many cases eliminates the need to parallel or series current channels together to test high burden relays.

The following are typical output current and associated available compliance voltage values for the SMRT1D Current channel. The per channel output current and power ratings are specified in AC RMS values and peak power ratings. Specified duty cycles are based upon typical room ambient temperature.

Output Current	Power	Max V/Duty Cycle
1 A	15 VA	15.0 V RMS Continuous
4 A	200 VA (282 peak)	50.0 V RMS Continuous
15 A	200 VA (282 peak)	13.4 V RMS Continuous
32 A	200 VA (282 peak)	6.25 V RMS Continuous
60 A	319 VA (424 peak)	5.00 V RMS 1.5 s or 90 cycles
DC 200 W		

 The current amplifier output is protected from open circuits and thermally protected against prolonged overloads. In case of an open circuit or a thermal overload, the amplifier will automatically turn off, and a message to the user will be displayed indicating which condition exists.

### 1.4 Binary Inputs and Outputs

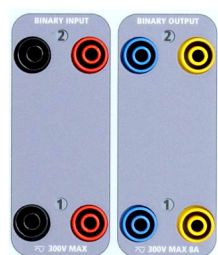

Figure 326 Binary Inputs and Outputs 1 and 2

Binary Inputs and Outputs are clearly marked and logically grouped. The Binary Inputs are used to monitor relay trip contacts for performing pickup and dropout tests as well as for performing timing functions. The Binary Outputs are used to simulate normally open/normally closed contacts for testing breaker failure schemes, or similar power system operations. In addition, they may also be used to switch AC/DC voltages and currents.

#### 1.4.1 Binary Inputs

The binary inputs are specifically designed to measure high speed operation of electro-mechanical, solid-state, and microprocessor-based protection relays. All binary Inputs default to Monitor Mode, contact change of state, latched OFF.

If using RTMS to change a binary input from Contact change of state to Voltage Applied/Removed click on or touch the Input Type window and a sine wave will appear where the Contact icon was indicating. The input is now set for voltage sensing.

To change the binary input from Monitor mode to Timer Mode, click on or touch the Use as Monitor button and the display window will change to show Use as Trip, Latched, meaning the binary input is now set to

stop the timer upon sensing the first contact closure (if the Input Type is set for contact) or upon sensing voltage if the Input Type is set to Voltage Sensing.

#### 1.4.1.1 Start, Stop, and Monitor Gates

In the SMRT1D there are two identical, independent, programmable gate circuits that permit simple selection of the desired mode for timing or contact monitoring operation.

To monitor operation of the contacts or trip SCR in the device under test, a light is provided for each gate. The gate circuit is isolated for voltage-sensing and can monitor solid-state logic signals. Each light will illuminate once contacts close or voltage is applied to the gate.

##### 1.4.1.1.1 Dry Contacts Open

Timer stops or a continuity indicator goes out at the opening of normally closed contacts, or when conduction through a semiconductor device, such as a triac or a transistor, is interrupted.

##### 1.4.1.1.2 Dry Contacts Close

Timer stops or a continuity indicator glows at the closing of the normally open contacts, or upon conduction through a semiconductor device such as a triac or a transistor.

##### 1.4.1.1.3 Application or Removal of AC or DC voltage

This will either start the Timer or stop the Timer. The continuity indicator will glow (application) or darkens (removal) upon the application or removal of either an AC or DC voltage. For typical test applications binary inputs 1 and 2 have a programmable voltage threshold from 2 to 150 V. The allowable voltage applied is 5 to 300 VAC or 5 to 300 VDC, current limiting resistors provide protection.

1.4.1.1.4 The Timer can be started when turning on any selected generators.

1.4.1.1.5 The Timer can be started simultaneously with a change in Frequency, Phase Angle, or Amplitude. Also, it can be started simultaneously with a Voltage or Current waveform step.

#### 1.4.2 Binary Outputs

Binary Outputs 1 and 2 are located on the top panel, rated for 300 V at 8 A. Each Binary Output can be configured as normally open or normally closed contacts providing logic to the device under test. Binary Outputs 1 and 2 have a rating of 300 V AC/DC, 8 A and a maximum of 2000 VA breaking capacity (80 Watt DC), with a response time of less than 10 ms.

The contacts may be programmed to open or close, thus simulating circuit breaker operation. The programmable wait duration is from one ms to 10,000 ms.

## 2.0 **SETUP**

### 2.1 Unpack System

Unpack the unit and check for evidence of any shipping damage. If there is any visual damage, immediately notify the freight carrier to make a damage claim and notify Megger of the damage.



**CAUTION:**

Potentially lethal voltages may be present on the output terminals. It is highly recommended the operator read the user manual thoroughly and understand the test set operation prior to turning power on.

2.1.1 Initial Start Up

1. With the Ethernet cable supplied with the unit connect the **IN** Ethernet Port on the SMRT unit to the Ethernet port on the PC Ethernet port.
2. Before connecting power to the unit, make sure the POWER ON/OFF Switch is in the OFF position (0). Plug the unit line cord into an appropriate power source and turn the POWER ON/OFF Switch to ON (I). As the SMRT unit goes through its power up sequence, in about a minute the STVI power up screen will appear, then the manual start up screen will appear.

2.2 **Communication Ports**

There are several communication ports. These ports are: two Ethernet, and two USB.

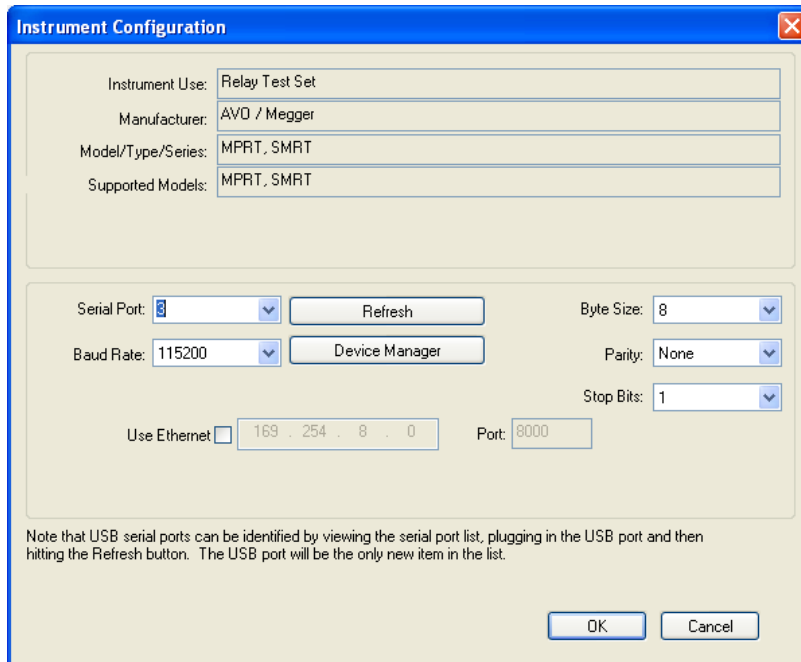

Figure 327 SMRT1D Communication Ports

2.2.1 **USB 3.0 Interface**

The USB Type A port is intended for use with downloading RTMS, SMRT firmware, or stored PowerDB test results. A USB keyboard or mouse can also be used with the STVI. The Type B USB Interface requires a Type B “downstream” connector and is primarily used as a communication and control port when used with a PC and Megger RTMS PC version for automated relay testing. It is recommended that you use the Ethernet port for high speed communication and control of the SMRT unit. Using the USB port will require the user to configure the PC com port for USB operation. Clicking on the Instrument

Setup icon on the PowerDB tool bar , the Instrument Configuration Screen (shown in the following figure)



provides the user with access to the PC Device Manager screen. Click on the Device Manager button and navigate to the USB Ports file directory. Since the SMRT1D defaults to a baud rate of 115,200, the user will need to configure their USB output com port to match. Returning to the Instrument Configuration screen the user will need to check off the Use Ethernet check box, and set the Baud rate, Byte Size and Stop Bits as shown.

## 2.2.2 IN Ethernet Port

**IN** Ethernet Port is the primary PC connection port for automated relay testing. This port supports MDI/MDI-X auto crossover configuration, which means both standard and “crossover” Ethernet cables may be used. Use this port for standard automated relay testing. This port provides the optimal method for downloading COMTRADE files, DFR streaming, and updating the unit’s firmware as required. For multiple unit operation, the unit providing the OUT link is providing the primary phase reference to all units “downstream.” For multiple unit operation connect the OUT port to the downstream SMRT unit IN port. RTMS will automatically configure when the units are powered up.

### 2.2.2.1 Setting SMRT IP Address for Operation with a PC

With the Ethernet cable supplied with the unit, connect the **IN** Ethernet Port on the SMRT unit to the PC Ethernet port. Turn the test set on. As the SMRT unit goes through its power up sequence, in less than a minute the STVI power up screen will appear. If using the PC version of RTMS it will auto-detect the SMRT unit connected to the PC. Once it auto-detects the unit, and determines the configuration of the SMRT unit connected, the Manual screen will appear. The unit might not auto detect due to firewall settings. In this case the firewall can be turned off or you can enter the IP address directly using the PowerDB instrument configuration screen by clicking on the Instrument Setup icon on the PowerDB tool

bar . From the Instrument Configuration Screen, shown in the following figure, click off the check mark in the Auto Discover Unit box.

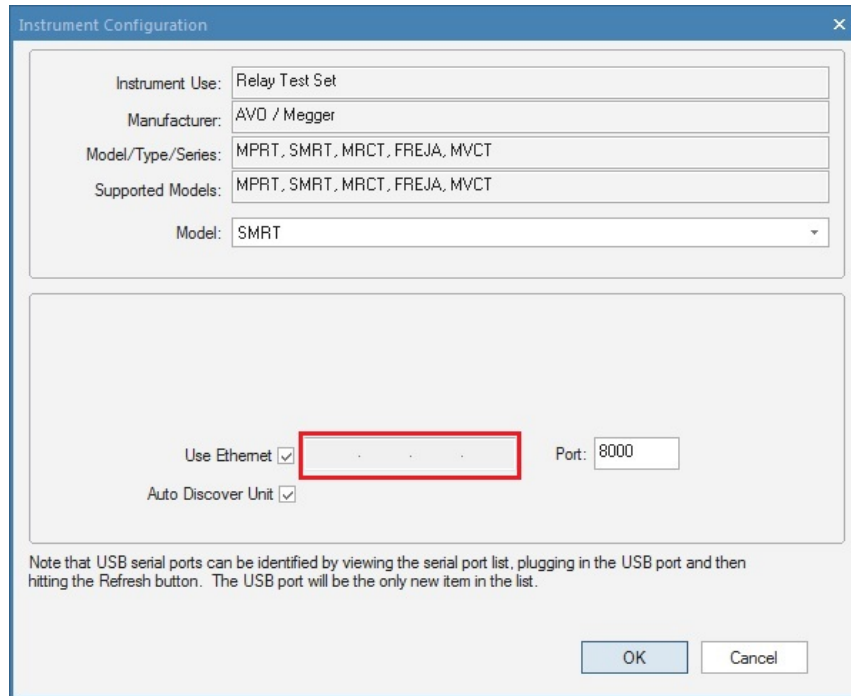

Figure 328 PowerDB Instrument Setup Screen

With the Auto Discover Unit box checked RTMS should find the unit. If not, the IP address can be entered in the box highlighted in the figure above. Also note that the IP address is also printed on the unit nameplate sticker. If the unit is on a network with a DHCP server, the user must use the Auto Discovery mode.

### 2.2.3 IN Ethernet Port

For IEC 61850 testing connect Ethernet OUT port to the substation bus or to the relay under test to receive and send GOOSE messages. Connect the Ethernet IN port to the PC. When used with the Megger GOOSE Configurator software, the SMRT can provide high speed testing of IEC 61850 relays and substations by subscribing to GOOSE messages and mapping to the binary inputs. In addition, it can simulate system conditions such as circuit breaker operation by publishing GOOSE messages mapped to the SMRT binary outputs. With the PC running Megger GOOSE Configurator and connected to the Ethernet IN port, the operator can “sniff” the substation network from the Ethernet OUT port through the IN port with the SMRT serving as the firewall. With this design the operator cannot accidentally trip off the substation or infect a PC virus into the substation LAN.

### 2.2.4 IEC61850/OUT Ethernet Port

The IEC 61850/OUT Ethernet Port is a 10/100BaseTX port and is primarily used to interconnect multiple SMRT units together for synchronous multi-unit operation. It is also be used to provide access to the substation IEC 61850 network (when enabled). The SMRT1D with the IEC 61850 option provides selectable priority, VLAN-ID, and meets the IEC 61850-5 standard Type 1A, Class P two-thirds, for high speed trip and reclose simulations. For multiple unit operation, the unit providing the OUT link is providing the primary phase reference to all units “downstream.” With the PC connected to the PC Port, the SMRT and the PC share the same Ethernet network connection, and thus will not have secure isolation from each other. When testing IEC 61850 devices connect the PC to the IN Ethernet port to isolate the PC from the IEC 61850 substation bus.

### 2.2.4.1 Setting SMRT IP Address for Networks or IEC 61850 Operations



The SMRT1D may be controlled over a network. This provides remote control of the SMRT1D over any distance allowing one PC to control at least two units simultaneously, such as in end to end testing. *Connecting the SMRT1D to a Local Area Network or a Wide Area Network could permit unauthorized operation of the unit.*

Through the IN Ethernet port, the SMRT1D integrates into a network just like a PC or server. Using this feature requires the user to set up the IP configuration of the SMRT1D for their LAN. Note that the SMRT1D when turned on will automatically search for and acquire a network address if connected to a network. If it fails to automatically acquire an address check to make sure you are properly connected using a standard Ethernet cable. **Do not** use a “cross-over” Ethernet cable (a cross over cable is designed for use from your PC to the test set, not to a network). If the unit still fails to acquire an address, then there may be other issues. This will require assistance from your company’s information management department.

## 3.0 Current Sources

### 3.1 Parallel Operation

Each SMRT1D current amplifier can provide 32 A continuous, and up to 60 A for 1.5 s or ninety cycles for testing instantaneous trip elements. When more than 32 A single phase is required for long durations, or 60 A for testing instantaneous elements, two current channels can be connected in parallel to provide 64 A continuous. For higher output currents, two SMRT1D channels can provide up to 120 A.

To parallel the current channels of the unit, perform the following:

If using the current test leads connect each current channel to the relay under test (both red and black terminals to the load). Each Megger test lead is rated 32 A continuous. If using test leads other than those supplied by Megger, ensure that the wire has sufficient size to carry the test current.

 All the return leads will need to be common together **at the load** as shown in the following figure.

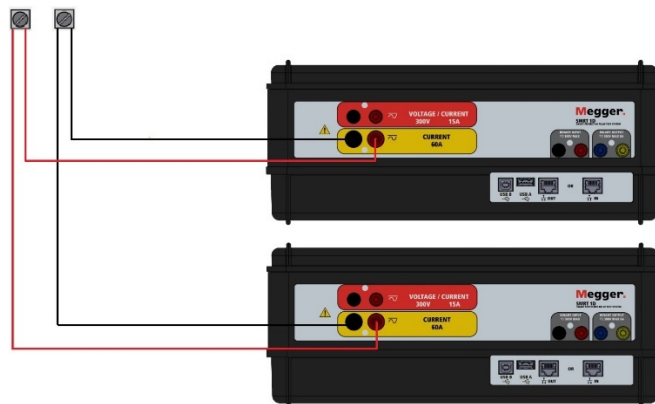

Figure 329 Parallel of Two SMRT1D Current Outputs

### 3.1.1 Manual Test Screen - Single Phase Up To 120 A

For ease of use and operator convenience, go to the Configuration screen and select the Operating Mode of **2 Voltages – 1 Current @ 120A**. When you return to the manual test screen there will be one current channel displayed, as shown in the following figure.

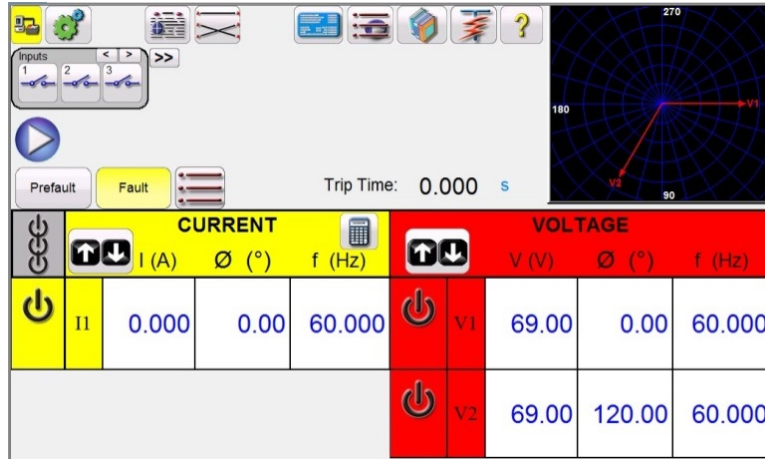





Figure 330 Manual Test Screen – SMRT1D Single Phase Operation

The STVI will automatically set the two currents in phase with each other and divide the current equally between the two current amplifiers. When setting an output, simply enter the value of the desired output current. For example, for an output of 75 A, enter 75, while each current amplifier will be providing 37.5 A. The current can also be phase shifted. Simply enter the desired phase angle and all currents will be phase shifted together.

Always use the ALL ON/OFF  button to turn both current channels on and off together. For manually ramping outputs, if using the PC version of RTMS the  buttons will be displayed. If using an STVI controller the Control Knob icon  will be displayed. Pressing either of these two will present the user with a window to select the desired level of increment for manually ramping the outputs, the desired channel(s) to be ramped, and what is to be adjusted (amplitude, phase angle or frequency).

### 3.2 Currents in Series Operation

Two current channels may be connected in series to double the available compliance voltage. High impedance electromechanical ground (earth) overcurrent relays have always been difficult to test at high multiples of tap due to the winding impedance and saturation characteristics. The peak voltage required can exceed the maximum output voltage of one SMRT1D current output channel, depending on the required test current. By connecting two current outputs in series, the compliance voltage is doubled, providing higher test currents through the load. Connect the two current amplifiers in a “push-push” configuration as shown in the following figure.

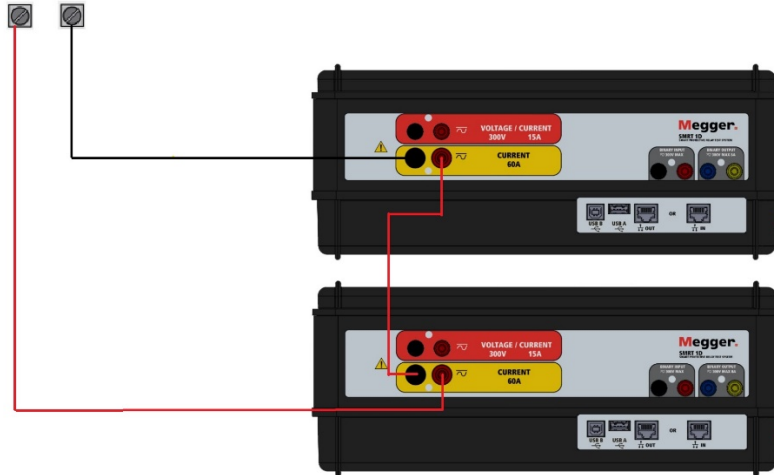



Figure 331 Two SMRT1D Current Channels in Series

The two current channels that are to be used in series set each to the same test current magnitude, and phase angle. Select both current channels and turn output on by pressing or clicking on the ALL ON/OFF button. Always use the ALL ON/OFF button to turn both current channels on and off together. For manually ramping outputs, if using the PC version of RTMS the  $\uparrow\downarrow$  buttons will be displayed. If using an STVI controller the Control Knob icon  will be displayed. Pressing either of these two will present the user with a window to select the desired level of increment for manually ramping the outputs, the desired channel(s) to be ramped, and what is to be adjusted (amplitude, phase angle or frequency).

#### 4.0 Voltage Sources

##### 4.1 Outputs Summed Together

Two voltage channels may be used to sum the voltage outputs to obtain higher than rated voltage provided the load is ungrounded. Connect the load between the voltage channel posts, set  $V_1$  Phase to zero° and set  $V_2$  Phase to 180°. The voltage outputs will add so the total voltage is the sum of the two voltage amplitudes,  $V_1$  and  $V_2$  as can be seen in the following figures.

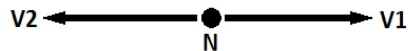

 Note: If an **F** or **C** appears in the fifth digit of the style identification number (i.e., 10NxFxxxx) the voltage returns are floating (isolated from each other and ground).

For the floating commons, the user must connect the associated voltage channels black common returns together, when series operation is required (see the following figures). Remove external commons when testing is completed.

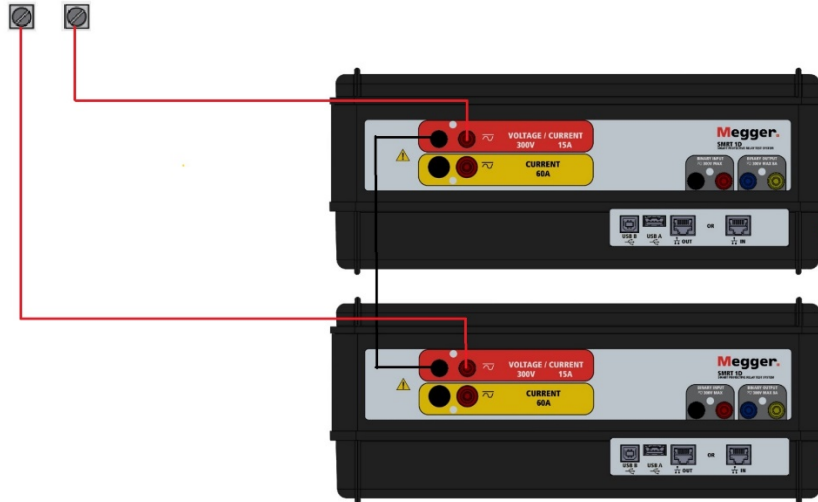

Figure 332 Series of Voltage Channels for **Floating Ungrounded Common Returns**

#### 4.2 3Ø, 3-Wire, Open-Delta

See section 3.4.2 in RTMS for detailed descriptions and use of the Open-Delta.

##### 4.2.1 Balanced Open Delta

The Open-Delta configuration is easy to use when a balanced three-phase source is required because the amplitude and phase relationship can be set directly. No calculations are necessary. When using the Open-Delta configuration, it is suggested to use voltage channel #1, designated  $V_1$ , and voltage channel #2, designated  $V_2$ , while the COMMON binding post is designated  $V_g$ . With this arrangement, the magnitude and phase angle of the potentials can be easily calculated and set. For the balanced three-phase condition  $V_{1g}$  and  $V_{2g}$  are equal in magnitude and separated by an angle of  $60^\circ$ . This is done by setting the  $V_1$  and  $V_2$  potentials equal in magnitude, setting  $0^\circ$  on  $V_1$  and  $300^\circ$  (60 degrees leading assuming that the default phase rotation is set to 360 Lag) on  $V_2$ , see the following figure.

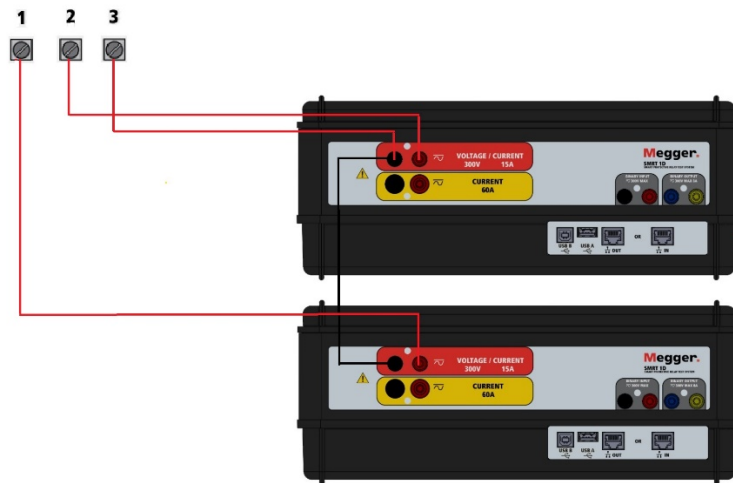

Figure 333 Two SMRT1D's Three Phase Open Delta Connections

# Megger<sup>®</sup>

## Addendum C



\* SMRT36 shown with "P" Plus option (Extra Binary Inputs / Outputs and battery simulator)

## **Model SMRT33/36/43/46. Megger Relay Tester**

## 1.0 Operation

The unit's design is a "modular" concept. All inputs and outputs are clearly marked and logically grouped so continual reference to the instruction manual should not be necessary once the operator is acquainted with the test system. The unit's Top Panel will appear different among units, since each unit may have up to three optional Voltage/Current Generator (VIGEN) Modules installed. The 'N' version consists of a system board with only power and communication ports. The 'P' version adds 8 additional binary inputs, 4 additional binary outputs and a battery simulator.

### 1.1 General Description

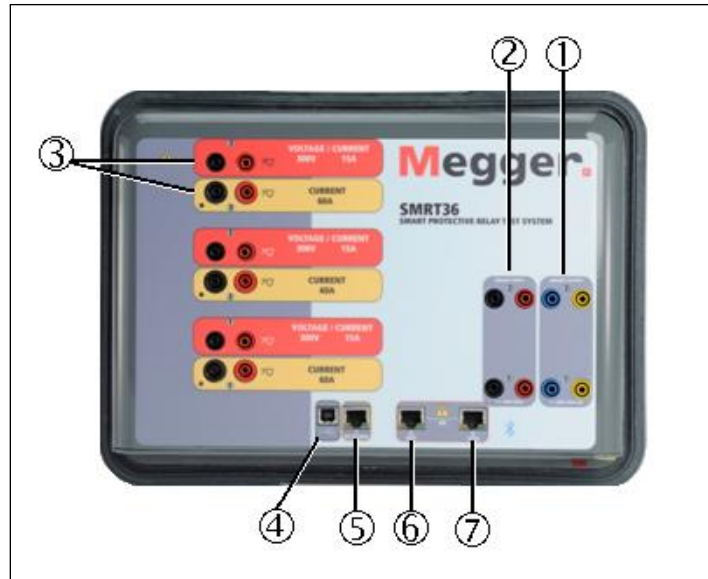

Figure 334 Top Panel (SMRT36 Pictured with Floating Returns Option)

#### 1.1.1 Top Panel

9. ① **Binary Outputs** – the first two VIGEN modules include Binary Inputs and Binary Outputs. Therefore, with a minimum 2 channel unit there are 2 Binary Outputs located on the top panel (numbered 1 and 2). More Binary Outputs are available with the P option see Front Panel section for more information. Each Binary Output can be configured as Normally Open or Normally Closed contacts providing logic to the device under test. The Top Panel Binary Outputs can switch up to 300 VAC or 250 VDC with 8 A continuous. The programmable wait duration is from 1 ms to 10,000 ms.
10. ② **Binary Inputs** – with a minimum 2 channel unit there are 2 Binary Inputs located on the top panel. For typical test applications, binary inputs 1 and 2 have a fixed voltage threshold of 5 V. Newer units may have programmable voltage thresholds on Binary Inputs 1 & 2 from 2 to 150 V AC/DC. For **GPS End-to-End synchronized relay testing Binary 1** may relate to a remote trigger pulse from a GPS satellite receiver for external initiation, or the input of an **IRIG-B** signal (see use of **Wait IRIG-B** input using the STVI Sequencer test). More Binary Inputs are available with the P option see Front Panel section for more information. The Binary Inputs will accept a voltage range of 5 to 300 VAC, or 5 to 250 VDC, or dry Normally Open/Normally Closed contacts.

11. ③ **Voltage/Current Generator Module (or VIGEN)** –There are three available slots for the VIGEN Modules. The slots are numbered 1 to 3 from bottom to top, with the topmost VIGEN numbered 3. The three phase voltages and currents are noted by the red and yellow surrounding each output channel. Phases A, B and C Voltage Channels (V1, V2 and V3) are denoted by the red color. Phases A, B and C Current Channels (I1, I2 and I3) are denoted by the yellow color. When the voltage generators are converted to current generators, they will change on the STVI display as V1 = I4, V2 = I5 and V3 = I6. For more details on the VIGEN output capabilities see section 1.4.

**Note: The SMRT33/43 voltage channels are not convertible to currents.**

12. ④ **USB Interface** – the USB 2.0 Interface requires a Type B “downstream” connector and is primarily used as a communication and control port when used with a PC and Megger RTMS for automated relay testing. A USB cable is not provided with the test set or in the optional accessories. For computer control, an Ethernet cable is provided. However, should the user desire to use the USB port any standard USB A/B cable will work with the unit. May be used when isolation is required for a secure substation access between the SMRT and the IEC 61850 substation network.
13. ⑤ **PC/OUT Ethernet Port** is a 10/100BaseTX port and is the primary PC connection port. This port supports MDI/MDI-X auto crossover configuration, which means both standard and “crossover” Ethernet cables may be used. This port provides the optimal method for downloading EMTP files, DFR streaming, and updating the unit’s firmware as required. The SMRT comes standard with a crossover cable. This port may also be used for connecting to the IEC 61850 substation bus for use in testing IEC 61850 devices. For multiple unit operation, the unit providing the OUT link is providing the primary phase reference to all units “downstream.”
14. ⑥ **IN - 61850 Ethernet Port** is a 10/100BaseTX port and is primarily used to interconnect multiple SMRT units together for synchronous multi-unit operation. It may also be used to provide access to the substation IEC 61850 network. Note that the IN and STVI ports share a common physical port and cannot be used at the same time. With the PC connected to the PC Port, the SMRT and the PC share the same Ethernet network connection, and thus will not have secure isolation from each other.
15. ⑦ **STVI Ethernet Port** – this Ethernet port is a 10/100BaseTX PoE (Power over Ethernet) port and is the STVI connection port. Used for manual operation, and display outputs when under computer control.

### 1.1.2 Front Panel:

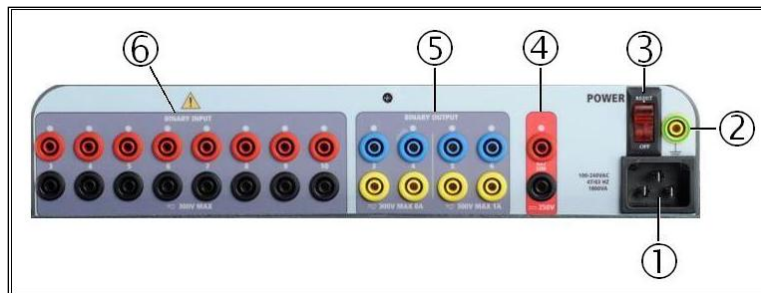



Figure 335 SMRT36 with P Option Front Panel

1. **① Incoming Power/Line Cord** – the input line cord, ground terminal, are mounted on the front panel of the test set for both the N and P option units.

#### Input Line Cord



The test set is equipped with a line cord, which connects to the male connector on the front panel. Verify the input voltage rating on the front panel before connecting the line cord to the power source.

2. **② Earth Ground Jack** – use this terminal to connect chassis ground to earth ground.
  -  A chassis ground (earth) point on the front panel is provided as an additional safety ground.
3. **③ POWER ON/OFF Switch** – used to switch unit on and off. The switch illuminates when power is on.
4. **④ Battery Simulator or AC/DC AUX** – the SMRT36 with the P option provides a variable dc output voltage from 5 to 250 V, at 100 W (4 A Max) providing logic voltage for solid-state relays. When powered ON, the LED above the output terminals illuminates. The SMRT33/36 with the N option does not include a battery simulator. The SMRT46 provides an AC/DC AUX Output with a continuously variable dc output voltage from 5 to 250 V, at 100 W (3.33 A Max) providing logic voltage for solid-state relays, or use as a reference ac voltage source for synchronizing or polarization potential from 0 – 150 V, 100 VA. When powered ON, the LED above the output terminals illuminates.
5. **⑤ Binary Outputs** – the P option provides 4 additional Binary Outputs, numbered 3, 4, 5 and 6. Each Binary Output can be configured as Normally Open or Normally Closed contacts providing logic to the device under test. Binary Outputs 3 and 4 have an AC Rating of 400 V max., I<sub>max</sub>: 8 A, 2000 VA max. breaking capacity, and a DC Rating of 300 V max., I<sub>max</sub>: 8 A, 80 W, with a Response Time: < 10ms. Binary Outputs 5 and 6 are high speed and have an AC/DC Voltage Rating of 400 V peak, I<sub>max</sub>: 1 A, with a Response Time: < 1ms typical. The programmable wait duration is from 1 ms to 10,000 ms. An LED directly above the terminals indicates the status of the contact. ON indicates closed, and OFF indicates open. The SMRT33/36 with the N option does not include the additional Binary Outputs 3 through 6.

6. **Ⓢ Binary Inputs** – the P option provides 8 additional (numbered 3 through 10), independent, galvanically isolated, Start/Stop or Monitor circuits to monitor operation of relay contacts or trip SCR. A continuity light is provided for each input gate. Upon sensing continuity, or voltage applied, the lamp will glow. In addition to serving as wet/dry contacts the Binary Inputs may be programmed to trigger binary output sequence(s). Binary Inputs can also be programmed using Boolean logic for more complex power system simulations. The Binary Inputs will accept a voltage range of 5 to 300 VAC or 5 to 250 VDC, or dry Normally Open/Normally Closed contacts. The SMRT33/36 with the N option does not include the additional Binary Inputs 3 through 10.

## 1.2 Input Power

The input voltage rating may be from 100 to 240 VAC,  $\pm 10\%$ , 50/60 Hz. The maximum input power is 1800 VA. The input is protected by a power ON/OFF switch/circuit breaker.

### 1.2.1. Input Power Cord

Depending on the country, the power cord can come with a NEMA 5-15 male connector, a CEE 7/7 Schuko two prong connector, with International Color Coded pig-tail wires (light blue, brown and green with yellow stripe) with the insulation jacket stripped ready for installation of the appropriate male connector, or with UK power cord.

Model SMRT33/36 **X0XXXXAXXX** comes with a North American power cord (part number 620000).

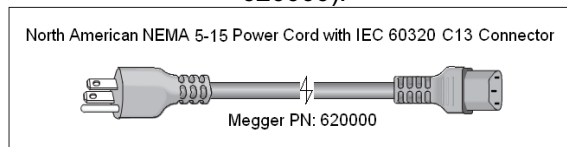

Model SMRT33/36 **X0XXXXEXXX** comes with a Continental Europe power cord (part number 50425).

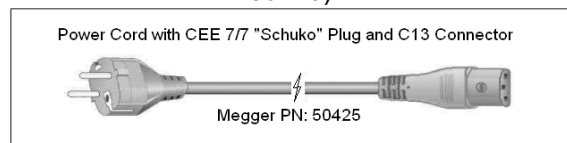

Model SMRT33/36 **X0XXXXIXXX** comes with an International Color Code power cord. The cord, part number 15065, is ready for wiring to the appropriate plug (depending on country). The following colors apply, Brown = Line, Blue = Neutral and Green/Yellow = Ground.

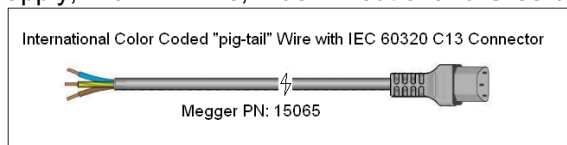

Model SMRT33/36 **X0XXXXUXXX** comes with a UK power cord (part number 90002-989).

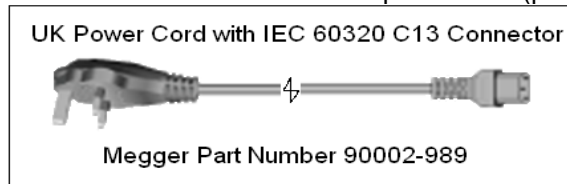

### 1.3 Voltage - Current Generator (VIGEN) Module

Voltages and Currents are noted by the red and yellow surrounding each output channel. Phases 1, 2 and 3 voltage channels are denoted by the red color. Phases 1, 2 and 3 current channels are denoted by the yellow color. All outputs are independent from sudden changes in mains voltage and frequency and are regulated so changes in load impedance do not affect the output. Standard amplifier outputs are isolated or floating. The SMRT units can be ordered with the amplifier common returns tied to chassis ground as an option.

#### 1.3.1. Convertible Voltage/Current Amplifier

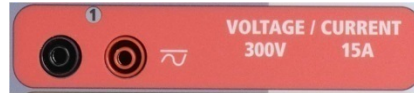

Figure 336 SMRT36/46 Voltage Channel

The SMRT PowerV™ voltage amplifier provides a flat power curve from 30 to 150 V in the 150 V range to permit testing of high current applications such as panel testing.

Voltage Range	Power/Current (Max)
30.00 V	150 VA @ 5.0 A
150.00 V	150 VA Constant Output Power from 30 to 150 V
300.00 V	150 VA @ 0.5 A

Voltage Amplifier in Current Mode<sup>4</sup>:

The SMRT36 voltage amplifier is convertible to a current source with the following output capability. Output power ratings are specified in RMS values and peak power ratings.

Output Current	Power	Max V	Duty Cycle
5 A	150 VA (212 peak)	30.0 V RMS	Continuous
15 A	120 VA	8.0 V RMS	1.5 s or 90 cycles

With a 3 channel SMRT unit, convertible channels in conjunction with the three main current channels, provides 6 currents for testing three phase current differential relays. When the voltage generators are converted to current generators, they will change on the STVI display as current phases 4, 5 and 6.

 The voltage amplifier output is protected from short circuits and thermally protected against prolonged overloads. In case of a short circuit or a thermal overload, the amplifier will automatically turn off, and if the STVI is connected a message to the user will be displayed indicating which condition exists.

#### 1.3.2. Current Amplifier



Figure 337 SMRT36/46 Current Channel

The SMRT current amplifier Constant Power Output feature delivers maximum compliance voltage to the load constantly during the test, and range changing is done automatically, on-the-fly, under load. This

<sup>4</sup> The SMRT33/43 Voltage Amplifier is not convertible to a current channel  
332

ensures better test results, saves time by not having to turn the outputs off to change output taps or ranges, and unlike single range current amplifiers insures a higher compliance voltage at lower test currents. Constant Power Output in many cases eliminates the need to parallel or series current channels together to test high burden relays.

The following are typical output current and associated available compliance voltage values for the SMRT33/43/36/46 Current channel<sup>5</sup>. The per channel output current and power ratings are specified in AC RMS values and peak power ratings. Specified duty cycles are based upon typical room ambient temperature.

Output Current	Power	Max V/Duty Cycle
1 A	15 VA	15.0 V RMS Continuous
4 A	200 VA (282 peak)	50.0 V RMS Continuous
15 A	200 VA (282 peak)	13.4 V RMS Continuous
32 A	200 VA (282 peak)	6.25 V RMS Continuous
45 A <sup>5</sup>	319 VA (424 peak)	6.67 V RMS 1.5 s or 90 cycles
60 A	319 VA (424 peak)	5.00 V RMS 1.5 s or 90 cycles
DC 200 W		

 The current amplifier output is protected from open circuits and thermally protected against prolonged overloads. In case of an open circuit or a thermal overload, the amplifier will automatically turn off, and if the STVI is connected a message to the user will be displayed indicating which condition exists.

#### 1.4 Binary Inputs and Outputs

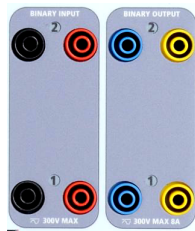

Figure 338 Binary Inputs and Outputs 1 and 2

Binary Inputs and Outputs are clearly marked and logically grouped. The unit's Top Panel will appear different among units, which means Binary Input/Output 1 will always be occupied while Binary Input/Output 2 may, nor may not, depending on the configuration. The 'N' version consists of a system board with only power and communication ports. The 'P' version adds 8 additional binary inputs, 4 additional binary outputs and a battery simulator. The Binary Inputs are used to monitor relay trip contacts for performing pickup and dropout tests as well as for performing timing functions. The Binary Outputs are used to simulate normally open/normally closed contacts for testing breaker failure schemes, or similar power system operations. In addition, they may also be used to switches AC/DC voltages and currents.



Figure 339 "P" Option Binary Inputs 3 to 10 and Binary Outputs 3 to 6

<sup>5</sup> The SMRT33/43 current channel is the same as the SMRT36/46 in terms of VA rating and compliance voltage. The SMRT33/43 current channel is limited to a maximum of 45 A vs. 60 A for the SMRT36/46.  
333

## 1.4.1 Binary Inputs

The binary inputs are specifically designed to measure high speed operation of electro-mechanical, solid-state, and microprocessor-based protection relays. All binary Inputs default to Monitor Mode, Contact change of state, latched OFF.

If using RTMS to change a binary input from Contact change of state to Voltage Applied/Removed click on or touch the Input Type window and a sine wave will appear where the Contact icon was indicating. The input is now set for voltage sensing.

To change the binary input from Monitor mode to Timer Mode, click on or touch the Use as Monitor button and the display window will change to show Use as Trip, Latched, meaning the binary input is now set to stop the timer upon sensing the first contact closure (if the Input Type is set for contact) or upon sensing voltage if the Input Type is set to Voltage Sensing.

### 1.4.1.1 Start, Stop, and Monitor Gates

In the SMRT33/43/36/46 there are up to ten identical, independent, programmable gate circuits that permit simple selection of the desired mode for timing or contact monitoring operation.

To monitor operation of the contacts or trip SCR in the device under test, a light is provided for each gate. The gate circuit is isolated for voltage-sensing and can monitor solid-state logic signals. Each light will illuminate once contacts close or voltage is applied to the gate.

#### 1.4.1.1.1 Dry Contacts Open

Timer stops or a continuity indicator goes out at the opening of normally closed contacts, or when conduction through a semiconductor device, such as a triac or a transistor, is interrupted.

#### 1.4.1.1.2 Dry Contacts Close

Timer stops or a continuity indicator glows at the closing of the normally open contacts, or upon conduction through a semiconductor device such as a triac or a transistor.

#### 1.4.1.1.3 Application or Removal of AC or DC voltage

This will either start the Timer or stop the Timer. The continuity indicator will glow (application) or darkens (removal) upon the application or removal of either an AC or DC voltage. To serve a wide range of test applications the binary inputs have different voltage thresholds. Depending on the age of the unit, binary inputs 1 and 2 may have programmable voltage thresholds from 2 to 150 V. Older units will have fixed voltage thresholds of 5 V AC/DC. On the "P" model there are an additional 8 binary inputs. To monitor TTL signals binary inputs 3 through 6 have a fixed threshold of 3 volts. Binary inputs 7 and 8 have fixed thresholds of 5 V, and binary inputs 9 and 10 have fixed threshold of 30 V (for "noisy" test environments). A higher threshold voltage helps to eliminate false triggers due to a noisy source. Lower thresholds allow starting and stopping of timer from TTL voltage signals. The allowable voltage applied is 5 to 300 VAC or 5 to 300 VDC, current limiting resistors provide protection.

#### 1.4.1.1.4 The Timer can be started when turning on any selected generators.

#### 1.4.1.1.5 The Timer can be started simultaneously with a change in Frequency, Phase Angle, or Amplitude. Also, it can be started simultaneously with a Voltage or Current waveform step.

## 1.4.2 Binary Outputs

Binary Outputs 1 and 2 are located on the top panel, rated for 300 V at 8 A. The SMRT36 “P” system board option provides four additional Binary Outputs numbered 3, 4, 5 and 6. Each Binary Output can be configured as normally open or normally closed contacts providing logic to the device under test. Binary Outputs 3 and 4 have a rating of 300 V AC/DC, 8 A and a maximum of 2000 VA breaking capacity (80 W DC), with a response time of less than 10ms. Binary Outputs 5 and 6 are high speed and have an AC/DC voltage rating of 400 V peak, 1 A and a response time typically less than 1ms.

The contacts may be programmed to open or close, thus simulating circuit breaker operation. The programmable wait duration is from 1 ms to 10,000 ms. A fused test lead (fused at 500 mA) is available as an optional accessory to help protect from blowing the internal fuse of binary outputs 5 & 6. The test lead is blue in color so that the user knows it applies to the blue binary outputs. The barrel holder of the test lead is CE marked with a 1000 V, CAT III rating, and marked FUSED 500 mA/1000 V/50 kA.

## 1.5 Battery Simulator



The SMRT36 “P” model includes the battery simulator, and provides a variable DC output from 5 to 250 VDC rated at 100 W, 4 A max. The SMRT43/46 includes an AC/DC Auxiliary Output that provides a variable DC output from 5 to 250 VDC rated at 100 W, 3.33 A max. User may select from normal setting values of 24, 48, 125, or 250 VDC, or enter the desired output voltage in the window provided, see RTMS Configuration Screen. Source may also be used as a synchronizing or polarization voltage providing 0 – 150 VAC at 100 VA. The output is variable using the STVI Control Knob, or the PC up/down cursor arrows (see the STVI section of the manual).



### CAUTION:

**NOTE: DC voltage is ON and available when the output is turned on using the LCD touch panel or via software command. Do not plug or insert any test lead into the BATTERY SIMULATOR binding posts without first connecting the test leads to the load!**

## 2.0 SETUP

### 2.1 Unpack System

Unpack the unit and check for evidence of any shipping damage. If there is any visual damage, immediately notify the freight carrier to make a damage claim and notify Megger of the damage.



### CAUTION:

**Potentially lethal voltages may be present on the output terminals. It is highly recommended the operator read the user manual thoroughly and understand the test set operation prior to turning power on.**

#### 2.1.1 Initial Start Up

1. With the Ethernet cable supplied with the unit connect the **STVI** Ethernet Port on the SMRT unit to the Ethernet port on the top of the Smart Touch View Interface (STVI). If using RTMS on a PC, connect the **PC/OUT** Ethernet Port on the SMRT unit to the PC Ethernet port.

- Before connecting power to the unit, make sure the POWER ON/OFF Switch is in the OFF position (0). Plug the unit line cord into an appropriate power source and turn the POWER ON/OFF Switch to ON (I). As the SMRT unit goes through its power up sequence, in about a minute the STVI power up screen will appear, then the manual start up screen will appear.

## 2.2 Communication Ports

There are several communication ports. These ports are: one USB, three Ethernet, and an optional Bluetooth wireless port. To connect with Bluetooth, the activation code is 0000 (that is four zeros).

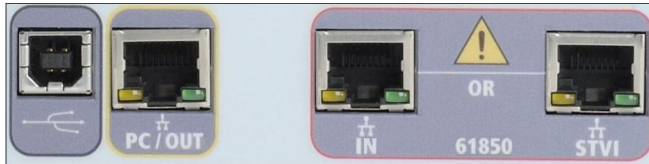

### 2.2.1 USB 2.0 Interface

USB 2.0 Interface requires a Type B “downstream” connector and is primarily used as a communication and control port when used with a PC and Megger RTMS or RTMS on a STVI for automated relay testing. It is recommended that you use the Ethernet port for high speed communication and control of the SMRT unit. Using the USB port will require the user to configure the PC com port for USB operation. Clicking on

the Instrument Setup icon on the PowerDB tool bar , the Instrument Configuration Screen (shown in the following figure)

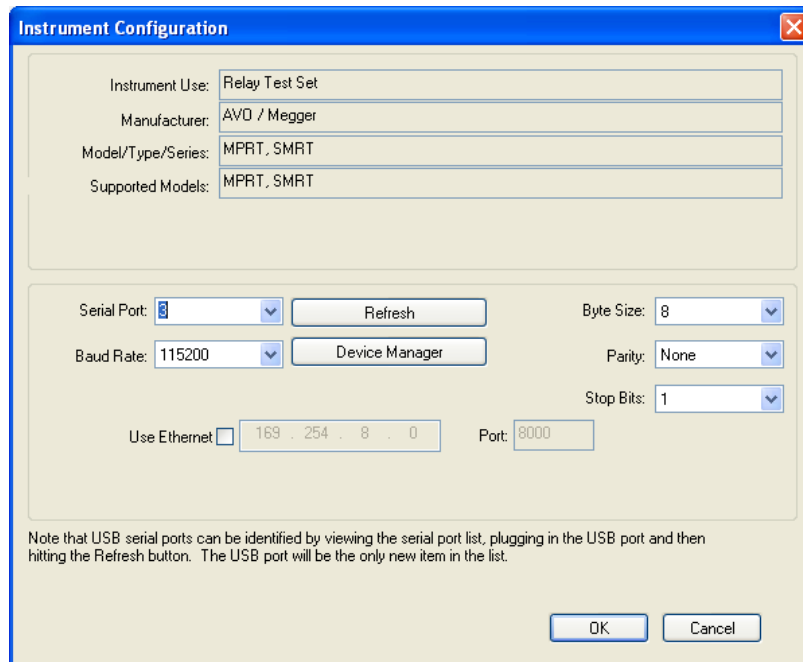

provides the user with access to the PC Device Manager screen. Click on the Device Manager button and navigate to the USB Ports file directory. Since the SMRT33/43/36/46 **defaults to a baud rate of 115,200**, the user will need to configure their USB output com port to match. Returning to the Instrument Configuration screen the user will need to check off the Use Ethernet check box, and set the Baud rate, Byte Size and Stop Bits as shown.

## 2.2.2 PC/OUT Ethernet Port

PC/OUT Ethernet Port is a 10/100BaseTX port and is the primary PC connection port automated relay testing. This port supports MDI/MDI-X auto crossover configuration, which means both standard and “crossover” Ethernet cables may be used. The SMRT comes standard with a crossover cable.

In addition, this port may be used to download large blocks of data into the unit. It is used to download digital samples for DFR playback and download software/firmware updates. Each output channel can store up to 256,000 samples of Digital Data, such as in Digital Fault Recordings for DFR playback, and with up to six channels that equals over 1.5 million samples. Typically, the Ethernet port on the SMRT33/43/36/46 should download the data in 1 s or less. In addition to high-speed downloads of DFR data, the port is also used to talk to the SMRT33/43/36/46 unit via a Network.

This port may also be used to interconnect multiple SMRT units together for synchronous multi-phase operation.

### 2.2.2.1 Setting SMRT IP Address for Operation with a PC

With the Ethernet cable supplied with the unit, connect the **PC/OUT** Ethernet Port on the SMRT unit to the PC Ethernet port. Turn the test set on. As the SMRT unit goes through its power up sequence, in less than a minute the STVI power up screen will appear. If using the PC version of RTMS it will auto-detect the SMRT unit connected to the PC. Once it auto-detects the unit, and determines the configuration of the SMRT unit connected, the Manual screen will appear. The unit might not auto detect due to firewall settings. In this case the firewall can be turned off or you can enter the IP address directly using the PowerDB instrument configuration screen by clicking on the Instrument Setup icon on the PowerDB tool

bar . From the Instrument Configuration Screen, shown in the following figure, click off the check mark in the Auto Discover Unit box.

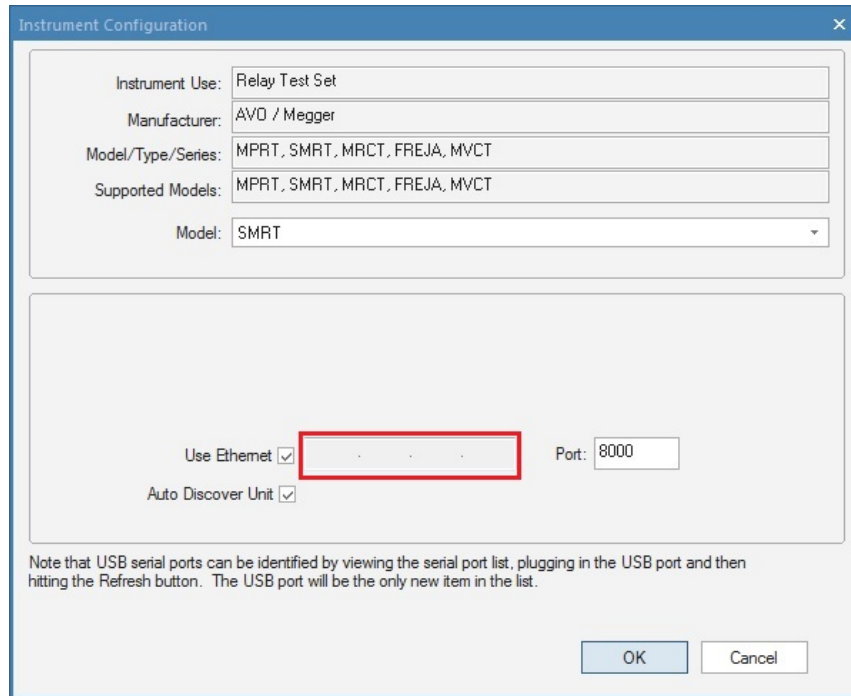

Figure 340 PowerDB Instrument Setup Screen

With the Auto Discover Unit box checked RTMS should find the unit. If not, the IP address can be entered in the box highlighted in the figure above. Also note that the IP address is also printed on the unit nameplate sticker. If the unit is on a network with a DHCP server, the user must use the Auto Discovery mode.

### 2.2.3 STVI Ethernet Port

**STVI** Ethernet Port is a 10/100BaseTX PoE (Power over Ethernet) port, which is the STVI connection port. This port provides power to the STVI using POE (Power Over Ethernet), and manual control of the SMRT unit with the STVI.

#### 2.2.3.1 Setting SMRT IP Address for Operation with STVI

With the Ethernet cable supplied with the unit, connect the **STVI** Ethernet Port on the SMRT top panel to the Ethernet port on the top of the Smart Touch View Interface (STVI). As the SMRT unit goes through its power up sequence, in less than a minute the STVI power up screen will appear. The STVI will auto-detect the SMRT unit (does not require the user to input an IP address). Once it auto-detects the unit, and determines the configuration of the SMRT unit connected, the Manual screen will appear.

### 2.2.4 IN - IEC61850 Ethernet Port

IN Ethernet Port is a 10/100BaseTX port and is used when interconnecting multiple SMRT units together. It also provide access to the substation IEC 61850 network (when enabled). The SMRT33/36/43/46 with the IEC 61850 option provides selectable priority, VLAN-ID, and meets the IEC 61850-5 standard Type 1A, Class P 2/3, for high speed trip and reclose simulations.

#### 2.2.4.1 Setting SMRT IP Address for Networks or IEC 61850 Operations



The SMRT33/43/36 or 46 can be controlled over a network. This provides remote control of the SMRT33/36/43/46 over any distance allowing one PC to control at least two units simultaneously, such as in end to end testing. *Connecting the SMRT33/43/36 or 46 to a Local Area Network or a Wide Area Network could permit unauthorized operation of the unit.*

Through the IN Ethernet port, the SMRT33/36/43/46 integrates into a network just like a PC or server. To use this feature requires the user to setup the IP configuration of the SMRT33/36/43/46 for their LAN. Note that the SMRT33/36/43/46 when turned on will automatically search for and acquire a network address if connected to a network. If it fails to automatically acquire an address check to make sure you are properly connected using a standard Ethernet cable. **Do not** use a “cross-over” Ethernet cable (a cross over cable is designed for use from your PC to the test set, not to a network). If the unit still fails to acquire an address, then there may be other issues. This will require assistance from your company’s information management department.

For IEC 61850 testing connect the IEC61850 IN port to the substation bus or to the relay under test to receive and send GOOSE messages. When used with the Megger GOOSE Configurator in RTMS, the SMRT (when equipped with the IEC 61850 Option) can provide high speed testing of IEC 61850 relays and substations by subscribing to GOOSE messages and mapping to the binary inputs. In addition, it can simulate system conditions such as circuit breaker operation by publishing GOOSE messages mapped to the SMRT33/36/43/46 binary outputs. With the PC connected to the OUT port, and running Megger GOOSE Configurator software (MGC), the operator can “sniff” the substation network. However, if a secure port is desired, where the operator cannot accidentally trip off the substation or infect a PC virus into the substation LAN, connect the PC to the SMRT USB port and sniff the network through the IEC61850 IN port.

### 3.0 Current Sources

#### 3.1 Parallel Operation

Each SMRT33/36/43/46 current amplifier can provide 32 A continuous. The SMRT33/43 can provide up to 45 A, while the SMRT36/46 can provide up to 60 A for 1.5 s for testing instantaneous trip elements. When more than 32 A single phase is required for long durations, or 60 A for testing instantaneous elements, two or three current channels may be connected in parallel to provide 60 or 90 A continuous. For higher output currents three SMRT33/43 channels can provide up to 135 A, while the SMRT36/46 can provide 180 A for short durations.

- Note: If an **F** or a **C** appears in the fifth digit of the style identification number (i.e., 30P1**F**0A0S1) the current returns are floating (isolated from each other and ground). Those units with a style number **G** or **E**, the current returns are common together internally and connected to earth ground.

To parallel the current channels of the unit, perform the following:

If using the sleeved multi-lead current test leads (part number 2008-541), all the black return leads are interconnected together inside the sleeve so they will all share the return current together. Connect each current channel to the relay under test (both red and black terminals to the load). Each Megger test lead is rated 32 A continuous. If using test leads other than those supplied by Megger, ensure that the wire has sufficient size to carry the test current.

□ For the earth grounded common return (G or C) units, there is an internal common ground between the current channel return terminals. If using separate individual test leads, all the return leads will need

to be common together at the load as shown in the following figure. By not connecting a return lead to all the current channels in use, part or all the return current will be forced through the internal ground. That means with a SMRT36/46 3 channel unit up to 180 A could be forced through the internal common ground and may cause damage to the internal common returns. Therefore, it is important that parallel connections must be made at the relay. See the following figure.

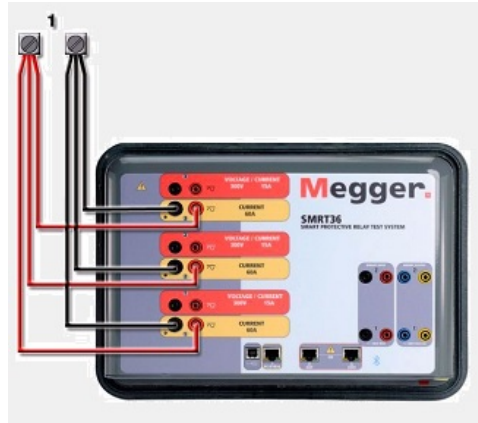

Figure 341 Parallel of All Three Current Outputs

### 3.1.1 Manual Test Screen - Single Phase Up To 180 A<sup>6</sup>

For ease of use and operator convenience, go to the Configuration screen and select the Operating Mode of **3 Voltages – 1 Current @ 180A**. When you return to the manual test screen there will be one current channel displayed, as shown in the following figure.

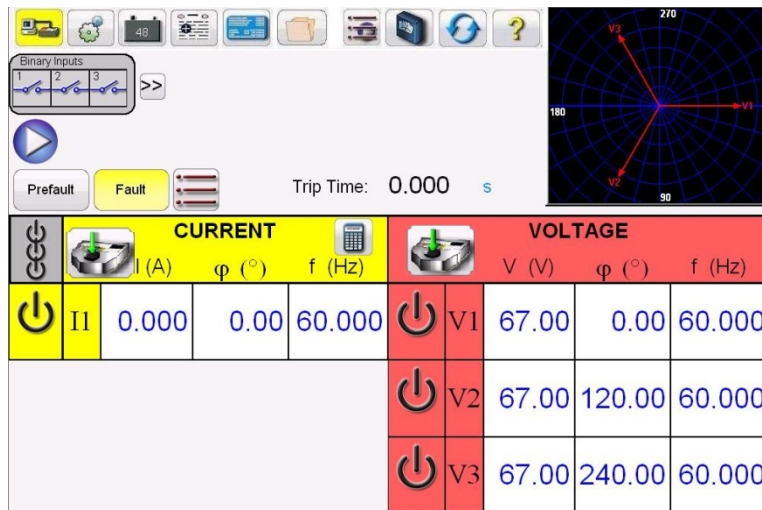

Figure 342 Manual Test Screen – SMRT36 Single Phase Operation

The STVI will automatically set all three currents in phase with each other and divide the current equally between the three current amplifiers. When setting an output, simply enter the value of the desired output

<sup>6</sup> The SMRT33/43 screen will look similar except for a limited maximum output current of 135 A vs. 180 A in the SMRT36/46.

current. For example, for an output of 75 A, enter 75, while each current amplifier will be providing 25 A. The current can also be phase shifted. Simply enter the desired phase angle and all three currents will be phase shifted together.

If two current channels are to be used in parallel, leave the unit in the default three phase configuration. Connect the two current outputs to the load as shown in the following figure.

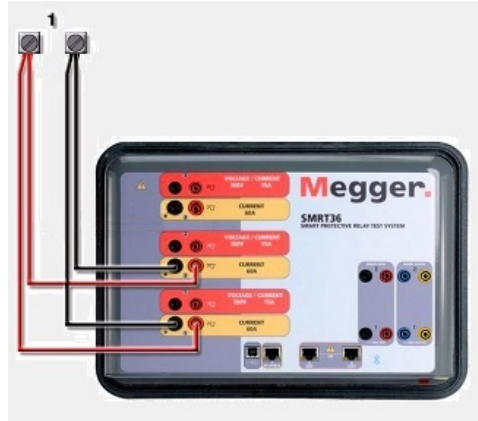



Figure 343 Two Currents in Parallel

Set each channel to one-half of the output requirement. Be sure and reset current channel #2 to 0 degrees so that it will be in-phase with current channel #1. With both current channels selected, turn output on by pressing or clicking on the ALL ON/OFF button. Always use the ALL ON/OFF button to turn both current channels on and off together. For manually ramping outputs, if using the PC version of RTMS the  $\uparrow\downarrow$  buttons will be displayed. If using an STVI controller the Control Knob icon  will be displayed. Pressing either of these two will present the user with a window to select the desired level of increment for manually ramping the outputs, the desired channel(s) to be ramped, and what is to be adjusted (amplitude, phase angle or frequency).

### 3.2 Currents in Series Operation

Two current channels may be connected in series to double the available compliance voltage. High impedance electromechanical ground (earth) overcurrent relays have always been difficult to test at high multiples of tap due to the winding impedance and saturation characteristics. The peak voltage required can exceed the maximum output voltage of one SMRT33/36/43/46 current output channel, depending on the required test current. By connecting two current outputs in series, the compliance voltage is doubled, providing higher test currents through the load. There are two methods to series currents together. For the floating output (F or C) models connect the two current amplifiers in a “push-push” configuration as shown in the following figure.

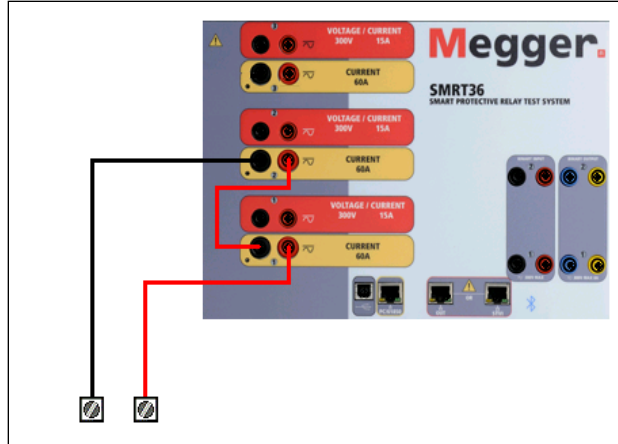



Figure 344 Series Two Currents with Floating Output Unit

The two current channels that are to be used in series set each to the same test current magnitude, and phase angle. Select both current channels and turn output on by pressing or clicking on the ALL ON/OFF button. Always use the ALL ON/OFF button to turn both current channels on and off together. For manually ramping outputs, if using the PC version of RTMS the  $\uparrow\downarrow$  buttons will be displayed. If using an STVI controller the Control Knob icon  will be displayed. Pressing either of these two will present the user with a window to select the desired level of increment for manually ramping the outputs, the desired channel(s) to be ramped, and what is to be adjusted (amplitude, phase angle or frequency).

To series the current channels of the common grounded returns (G or E) unit, perform the following:

Using the current channel test leads, connect the Red output terminals of the two current channels to the relay under test. Even though the two returns associated with the current channels are connected internally with the common returns, place a jumper as shown. This will ensure that the internal common leads will not be damaged.

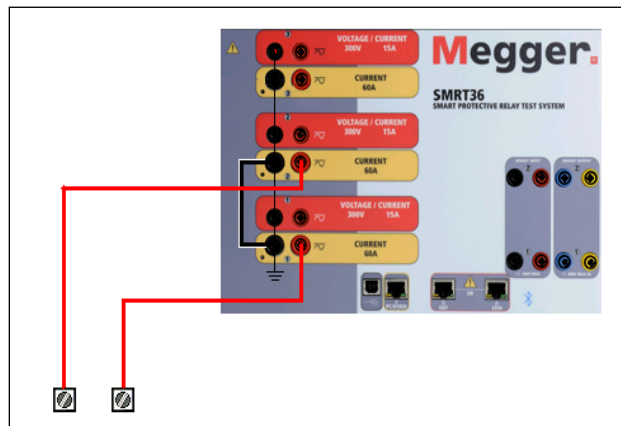



Figure 345 Series of Two Current Channels with Grounded Common Returns

 NOTE: One current channel should be set to 0 degrees and the other current channel should be set to a phase angle of 180 degrees so that the two compliance voltages add across the load. DO NOT attempt to series more than two currents together on a grounded common returns unit.

The two current channels that are to be used in series set each to the same test current magnitude. Initiate the two current channels simultaneously by pressing the ALL ON/OFF button. Always use the ALL ON/OFF button to turn both current channels on and off together. For manually ramping outputs, if using the PC version of RTMS the  $\uparrow\downarrow$  buttons will be displayed. If using an STVI controller the Control Knob icon  will be displayed. Pressing either of these two will present the user with a window to select the desired level of increment for manually ramping the outputs, the desired channel(s) to be ramped, and what is to be adjusted (amplitude, phase angle or frequency).

#### 4.0 Voltage Sources

##### 4.1 Outputs Summed Together

Two voltage channels may be used to sum the voltage outputs to obtain higher than rated voltage provided the load is ungrounded. Connect the load between the voltage channel posts, set  $V_1$  Phase to  $0^\circ$  and set  $V_2$  Phase to  $180^\circ$ . The voltage outputs will add so the total voltage is the sum of the two voltage amplitudes,  $V_1$  and  $V_2$  as can be seen in the following figures.

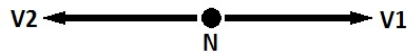

 Note: If an **F** or **C** appears in the 5<sup>th</sup> digit of the style identification number (i.e., 30P1**F**0A0S1) the voltage returns are floating (isolated from each other and ground). Those units with a style number **G** or **E** the voltage returns are common together internally and connected to earth ground.

For the floating common units, the user must connect the associated voltage channels black common returns together, when series operation is required (see the following figures). Remove external commons when testing is completed. DO NOT attempt to series more than two voltage channels together, since the voltage test leads are rated up to 600 V.

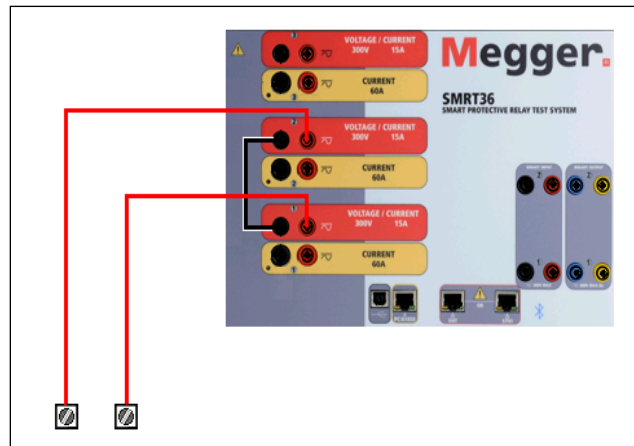

Figure 346 Series of Voltage Channels for **Floating Ungrounded Common Returns**

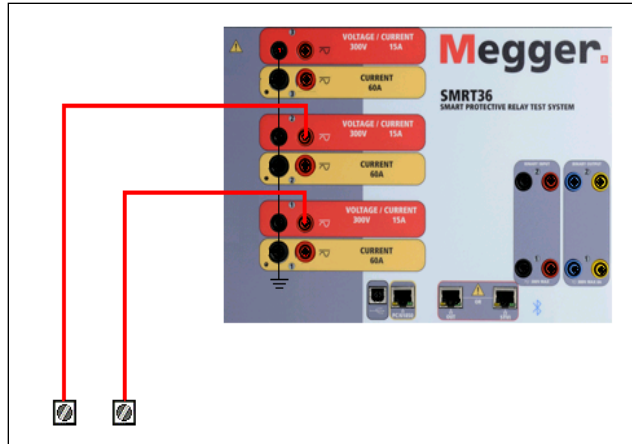

Figure 347 Series of Voltage Channels **with Grounded Common Returns**

#### 4.2 $3\phi$ , 3-Wire, Open-Delta, and T-Connection

See section 3.4.2 in RTMS for detailed descriptions and use of the Open-Delta and T-Connection.

##### 4.2.1 Balanced Open Delta

The Open-Delta configuration is easy to use when a balanced three-phase source is required because the amplitude and phase relationship can be set directly. No calculations are necessary. When using the Open-Delta configuration, it is suggested to use voltage channel #1, designated  $V_1$ , and voltage channel #2, designated  $V_2$ , while the COMMON binding post is designated  $V_g$ . With this arrangement, the magnitude and phase angle of the potentials can be easily calculated and set. For the balanced three-phase condition  $V_{1g}$  and  $V_{2g}$  are equal in magnitude and separated by an angle of  $60^\circ$ . This is done by setting the  $V_1$  and  $V_2$  potentials equal in magnitude, setting  $0^\circ$  on  $V_1$  and  $300^\circ$  ( $60^\circ$  leading assuming that the default phase rotation is set to  $360^\circ$  Lag) on  $V_2$ , see the following figure.

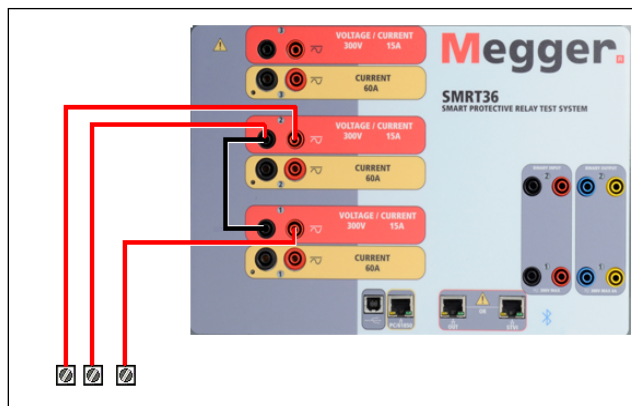

Figure 348 Three Phase Open Delta Connections

#### 4.2.2 T Connection

The second method of obtaining a three-phase, three-wire voltage source is the so-called T-Connection. The method, shown in the following figure, is easier to use when obtaining an unbalanced, phase - to -phase fault simulation since it eliminates calculations. To reduce confusion when using the T-Connection, the voltage output #1 is designated  $V_a$  and its phase angle set at  $0^\circ$ , voltage output #2 is designated  $V_b$  and its phase angle set for  $180^\circ$ , and voltage output #3 is designated  $V_c$  and its phase angle is set for  $270^\circ$ . Any combination of balanced three phase faults or unbalanced phase-to-phase fault conditions can be easily simulated.

**!** NOTE: This method should not be used for low fault voltages, or used on solid state relays that may be sensitive to this type of connection (i.e., 5 volts or less, or for testing ABB or Westinghouse type SKD relays).

**!** Note: If an **F** or **C** appears in the fifth digit of the style identification number (i.e., 30P1F0A0S1) the voltage returns are floating (isolated from each other and ground). Those units with a style number **G** or **E** the voltage returns are common together internally and connected to earth ground.

If using the sleeved multi-lead voltage test leads (part number 2001-395), all the black return leads are interconnected together inside the sleeve so they will all share the return together. Therefore, only one return lead is provided on the relay connection side of the sleeved leads (like the connections in the following figure).

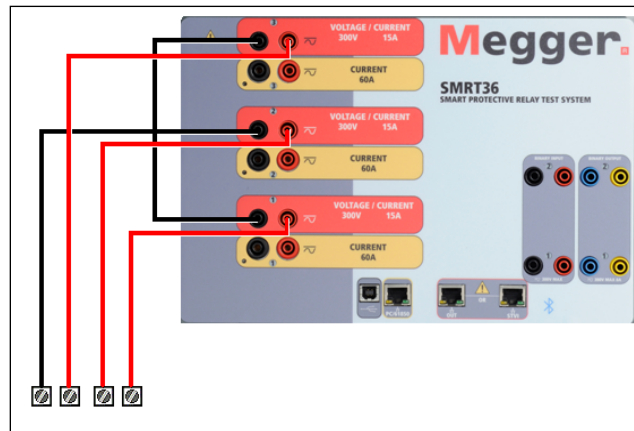

Figure 349 Three Phase Four Wire Test Connections

**!** For the earth grounded common return (G or E) units, there is an internal common ground between the voltage and current channel return terminals. Therefore, only one return lead is required for the voltage channels. If using separate individual test leads, for the floating common units the user must connect the associated voltage channels black common returns together as shown above.

# Addendum D



## Model SMRT36D Megger Relay Tester

## 1.0 Operation

The unit's design is a "modular" concept. All inputs and outputs are clearly marked and logically grouped so continual reference to the instruction manual should not be necessary once the operator is acquainted with the test system. The unit's Top Panel will appear different among units, since each unit may have up to three optional Voltage/Current Generator (VIGEN) Modules installed.

### 1.1 General Description

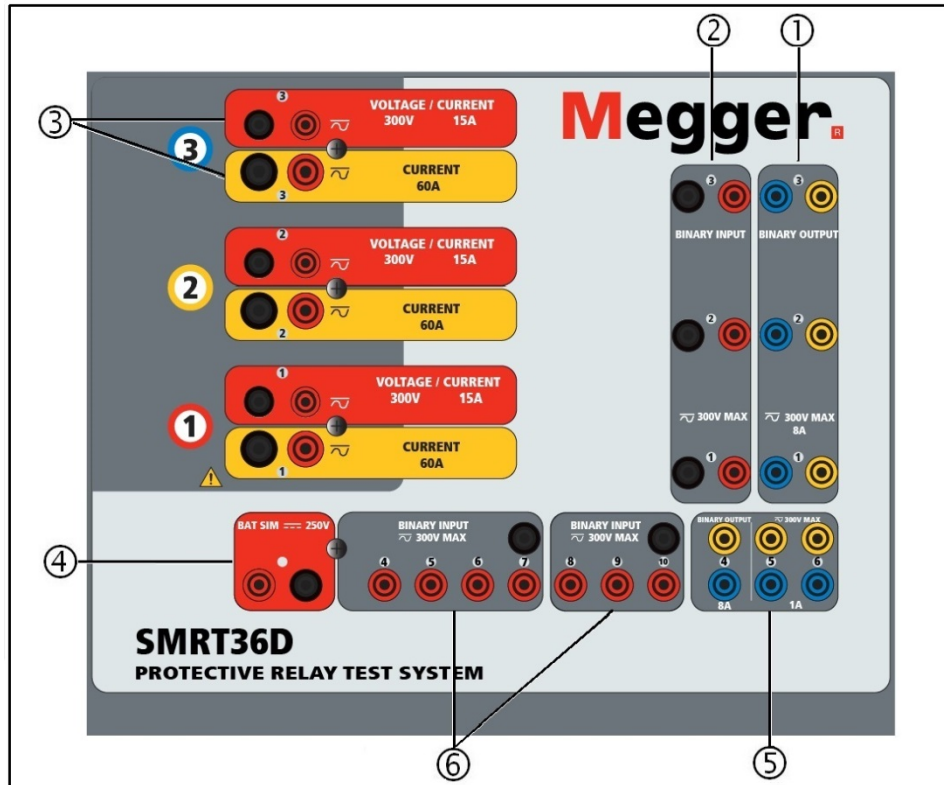

Figure 350 Top Panel SMRT36D (Pictured with Floating Returns Option)

#### 1.1.1 Top Panel

1. **Binary Outputs**<sup>7</sup> – the first three VIGEN modules include Binary Inputs and Binary Outputs. Therefore, with a minimum 2 channel unit there are 2 Binary Outputs located on the top panel (numbered 1 and 2). The 3<sup>rd</sup> Binary Output will be replaced with DC Input terminals if ordering the unit with the Transducer option. Each Binary Output can be configured as Normally Open or Normally Closed contacts providing logic to the device under test. The Binary Outputs 1, 2, and 3 can switch up to 300 VAC or 250 VDC with 8 A continuous. The programmable wait duration is from 1 ms to 10,000 ms.
2. **Binary Inputs**<sup>9</sup> – with a minimum of a 2 channel unit there are 2 Binary Inputs located on the top panel. The 3<sup>rd</sup> Binary Input will be replaced with DC Input terminals if ordering the unit with the Transducer option. To serve a wide range of test applications, the binary inputs 1 and 2 have a fixed voltage threshold of 5 V. Binary input 3 has a fixed threshold of 5 V. For **GPS End-to-End**

<sup>7</sup> If ordering the optional Transducer test feature the number of Binary Outputs and Inputs is reduced by 1  
347

**synchronized relay testing Binary 1** may relate to a remote trigger pulse from a GPS satellite receiver for external initiation, or the input of an **IRIG-B** signal (see use of **Wait IRIG-B** input using the STVI Sequencer test). There are an additional 7<sup>1</sup> binary inputs. To monitor TTL signals binary inputs 4 through 6 have a fixed threshold of 3 V. Binary inputs 7 and 8 have fixed thresholds of 5 volts, and binary inputs 9 and 10 have fixed threshold of 30 V (for “noisy” test environments). In addition to serving as Timer/Monitor inputs, the Binary Inputs may be programmed to trigger binary output sequence(s). Binary Inputs can also be programmed using Boolean logic for more complex power system simulations.



3. **Voltage/Current Generator Module (or VIGEN)** –There are three available slots for the VIGEN Modules. The slots are numbered 1 to 3 from bottom to top, with the topmost VIGEN numbered 3. The three phase voltages and currents are noted by the red and yellow surrounding each output channel. Phases A, B and C Voltage Channels (V1, V2 and V3) are denoted by the red color. Phases A, B and C Current Channels (I1, I2 and I3) are denoted by the yellow color. When the voltage generators are converted to current generators, they will change on the STVI display as V1 = I4, V2 = I5 and V3 = I6. For more details on the VIGEN output capabilities see section 1.4.
4. **Battery Simulator** – the SMRT36D provides a variable dc output voltage from 5 to 250 V, at 100 W (4 A Max) providing logic voltage for solid-state relays. When powered ON, the LED above the output terminals illuminates.
5. **Binary Outputs** – additional Binary Outputs can be configured as Normally Open or Normally Closed contacts providing logic to the device under test. Binary Output 4 has an AC Rating of 400 V max., I<sub>max</sub>: 8 A, 2000 VA maximum breaking capacity, and a DC Rating of 300 V max., I<sub>max</sub>: 8 A, 80 W, with a Response Time: < 10ms. **Binary Outputs 5 and 6 are high speed** and have an AC/DC Voltage Rating of 400 V peak, I<sub>max</sub>: 1 A, with a Response Time: < 1ms typical. The programmable wait duration is from 1 ms to 10,000 ms. An LED directly above the terminals indicates the status of the contact. ON indicates closed, and OFF indicates open.
6. **Binary Inputs** – additional, independent, galvanically isolated, Start/Stop or Monitor circuits to monitor operation of relay contacts or trip SCR. Continuity light is provided for each input gate. Upon sensing continuity, or voltage applied, the lamp will glow. In addition to serving as wet/dry contacts the Binary Inputs may be programmed to trigger binary output sequence(s). Binary Inputs can also be programmed using Boolean logic for more complex power system simulations. The Binary Inputs will accept a voltage range of 5 to 300 VAC or 5 to 250 VDC, or dry Normally Open/Normally Closed contacts.

### 1.1.2 Front Panel:

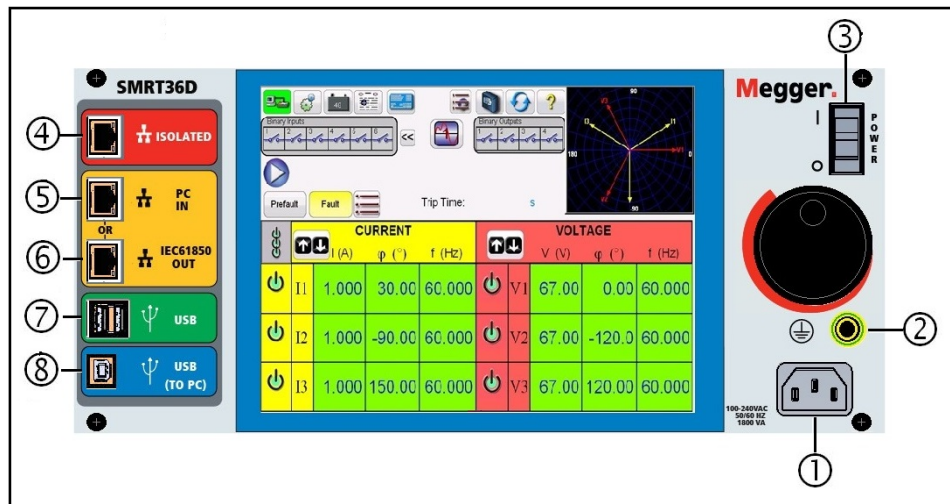

Figure 351 SMRT36D Front Panel

- Incoming Power/Line Cord** ① – the input line cord, ground terminal, are mounted on the front panel of the test set.

#### Input Line Cord



The test set is equipped with a line cord, which connects to the male connector on the front panel. Verify the input voltage rating on the front panel before connecting the line cord to the power source.

- Earth Ground Jack** ② – use this terminal to connect chassis ground to earth ground.



A chassis ground (earth) point on the front panel is provided as an additional safety ground.

- POWER ON/OFF Switch** ③ – used to switch unit on and off.

- ISOLATED** ④ For IEC 61850 testing connect IEC61850/OUT port to the substation bus or to the relay under test to receive and send GOOSE messages. Connect the ISOLATED port to the PC. When used with the Megger GOOSE Configurator in the RTMS, the SMRT can provide high speed testing of IEC 61850 relays and substations by subscribing to GOOSE messages and mapping to the binary inputs. In addition, it can simulate system conditions such as circuit breaker operation by publishing GOOSE messages mapped to the SMRT binary outputs. With the PC running Megger GOOSE Configurator and connected to the ISOLATED port, the operator can “sniff” the substation network from the IEC 61850/OUT port through the ISOLATED port with the SMRT serving as the firewall. With this design the operator cannot accidentally trip off the substation or infect a PC virus into the substation LAN.

- PC/IN** ⑤ Ethernet Port is the primary PC connection port for automated relay testing. This port supports MDI/MDI-X auto crossover configuration, which means both standard and

“crossover” Ethernet cables may be used. Use this port for standard automated relay testing. This port provides the optimal method for downloading EMTP files, DFR streaming, and updating the unit’s firmware as required. For multiple unit operation, the unit providing the OUT link is providing the primary phase reference to all units “downstream.” For multiple unit operation connect the OUT port to the downstream SMRT unit IN port. RTMS will automatically configure when the units are powered up.

12. **IEC61850/OUT** ⑥ Ethernet Port is a 10/100BaseTX port and is primarily used to interconnect multiple SMRT units together for synchronous multi-unit operation. It is also used to provide access to the substation IEC 61850 network. For multiple unit operation, the unit providing the OUT link is providing the primary phase reference to all units “downstream.” With the PC connected to the PC Port, the SMRT and the PC share the same Ethernet network connection, and thus will not have secure isolation from each other. When testing IEC 61850 devices connect the PC to the ISOLATED Ethernet port to isolate the PC from the IEC 61850 substation bus.
13. **USB Interface** ⑦ There is two type A ports available. This port is primarily used to update the firmware in the SMRT as well as update RTMS onboard using a USB memory stick. It may also be used to download test results from the SMRT for download onto another PC with PowerDB software for storage or printing. In addition, the user can use a USB keyboard, as well as a mouse, in conjunction with the STVI. Keyboard and/or mouse are not provided with accessories.
14. **USB (TO PC) Interface** ⑧ – The (TO PC) USB Interface requires a Type B “downstream” connector and is primarily used as a communication and control port when used with a PC and RTMS for automated relay testing. A USB cable is not provided with the test set or in the optional accessories. For computer control, an Ethernet cable is provided. However, should the user desire to use the USB port any standard USB A/B cable will work with the unit. May be used when isolation is required for a secure substation access between the SMRT and the IEC 61850 substation network.

## 1.2 Input Power

The input voltage rating may be from 100 to 240 VAC,  $\pm 10\%$ , 50/60 H. Input current required varies with the number of output modules in use, load, and input voltage value. With three VIGENS, the maximum input power is 1800 VA. The input is protected by a power ON/OFF switch / circuit breaker.

### 1.2.1 Input Power Cord

Depending on the country, the power cord can come with a NEMA 5-15 male connector, a CEE 7/7 Schuko two prong connector, with International Color Coded pig-tail wires (light blue, brown and green with yellow stripe) with the insulation jacket stripped ready for installation of the appropriate male connector, or with UK power cord.

Model SMRT36D **X0XXXXA** comes with a North American power cord (part number 620000).

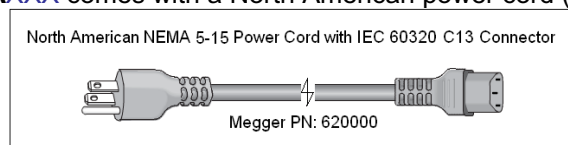

Model SMRT36D X0XXXXEXXX comes with a Continental Europe power cord (part number 50425).

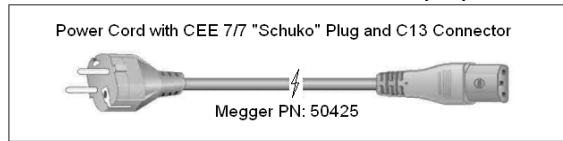

Model SMRT36D X0XXXXIXXX comes with an International Color Code power cord. The cord, part number 15065, is ready for wiring to the appropriate plug (depending on country). The following colors apply, Brown = Line, Blue = Neutral and Green/Yellow = Ground.

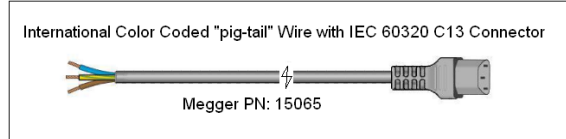

Model SMRT36D X0XXXXUXXX comes with a UK power cord (part number 90002-989).

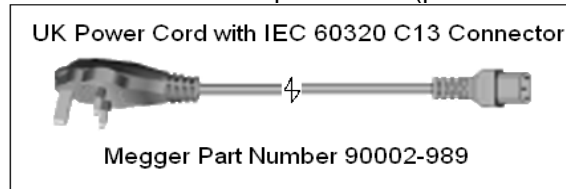

### 1.3 Voltage - Current Generator (VIGEN) Module

Voltages and Currents are noted by the red and yellow surrounding each output channel. Phases 1, 2 and 3 voltage channels are denoted by the red color. Phases 1, 2 and 3 current channels are denoted by the yellow color. All outputs are independent from sudden changes in mains voltage and frequency and are regulated so changes in load impedance do not affect the output. Standard amplifier outputs are isolated or floating. The SMRT units can be ordered with the amplifier common returns tied to chassis ground as an option.

#### 1.3.1. Convertible Voltage/Current Amplifier



The SMRT PowerV™ voltage amplifier provides a flat power curve from 30 to 150 Volts in the 150V range to permit testing of high current applications such as panel testing.

Voltage Range	Power/Current (Max)
30.00 V	150 VA @ 5.0 A
150.00 V	150 VA Constant Output Power from 30 to 150 V
300.00 V	150 VA @ 0.5 A

#### Voltage Amplifier in Current Mode :

The voltage amplifier is convertible to a current source with the following output capability. Output power ratings are specified in RMS values and peak power ratings.

Output Current	Power	Max V	Duty Cycle
5 A	150 VA (212 peak)	30.0 V RMS	Continuous
15 A	120 VA	8.0 V RMS	1.5 s or 90 cycles

With a 3 channel SMRT unit, convertible channels in conjunction with the three main current channels, provides 6 currents for testing three phase current differential relays. When the voltage generators are converted to current generators, they will change on the STVI display as current phases 4, 5 and 6.

**!** The voltage amplifier output is protected from short circuits and thermally protected against prolonged overloads. In case of a short circuit or a thermal overload, the amplifier will automatically turn off, and if the STVI is connected a message to the user will be displayed indicating which condition exists.

### 1.3.2. Current Amplifier

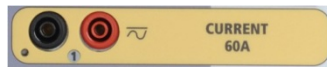

The SMRT current amplifier Constant Power Output feature delivers maximum compliance voltage to the load constantly during the test, and range changing is done automatically, on-the-fly, under load. This ensures better test results, saves time by not having to turn the outputs off to change output taps or ranges, and unlike single range current amplifiers insures a higher compliance voltage at lower test currents. Constant Power Output in many cases eliminates the need to parallel or series current channels together to test high burden relays.

The following are typical output current and associated available compliance voltage values. The per channel output current and power ratings are specified in AC RMS values and peak power ratings. Specified duty cycles are based upon typical room ambient temperature.

Output Current	Power	Max V/Duty Cycle
1 A	15 VA	15.0 V RMS Continuous
4 A	200 VA (282 peak)	50.0 V RMS Continuous
15 A	200 VA (282 peak)	13.4 V RMS Continuous
32 A	200 VA (282 peak)	6.25 V RMS Continuous
60 A	319 VA (424 peak)	5.00 V RMS 1.5 s or 90 cycles
DC 200 W		

**!** The current amplifier output is protected from open circuits and thermally protected against prolonged overloads. In case of an open circuit or a thermal overload, the amplifier will automatically turn off, and if the STVI is connected a message to the user will be displayed indicating which condition exists.

### 1.4 Binary Inputs and Outputs 1 and 2



Figure 352 Binary Inputs and Outputs 1 and 2

Binary Inputs and Outputs are clearly marked and logically grouped. The unit's Top Panel will appear different among units, which means Binary Input/Output 1 will always be occupied, while Binary Input/Output 2 may, nor may not, depending on the configuration. If the Transducer option is installed Binary Input/Output 3 will be replaced by the DC Input terminals, with a different overlay. The Binary Inputs are used to monitor relay trip contacts for performing pickup and dropout tests as well as for performing timing functions. The Binary Outputs are used to simulate normally open/normally closed contacts for testing breaker failure schemes, or similar power system operations. In addition, they may also be used to switches AC/DC voltages and currents.



Figure 353 Binary Inputs 4 to 10 and Binary Outputs 4 to 6

#### 1.4.1 Binary Inputs

The binary inputs are specifically designed to measure high speed operation of electro-mechanical, solid-state, and microprocessor-based protection relays. All binary Inputs default to Monitor Mode, Contact change of state, latched OFF. If using RTMS to change a binary input from Contact change of state to Voltage Applied/Removed click on or touch the Input Type window and a sine wave will appear where the Contact icon was indicating. The input is now set for voltage sensing.

To change the binary input from Monitor mode to Timer Mode, click on or touch the Use as Monitor button and the display window will change to show Use as Trip, Latched, meaning the binary input is now set to stop the timer upon sensing the first contact closure (if the Input Type is set for contact) or upon sensing voltage if the Input Type is set to Voltage Sensing.

##### 1.4.1.1 Start, Stop, and Monitor Gates

In the SMRT36D there are up to ten<sup>1</sup> identical, independent, programmable gate circuits that permit simple selection of the desired mode for timing or contact monitoring operation. To monitor operation of the contacts or trip SCR in the device under test, a light is provided for each gate. The gate circuit is isolated for voltage-sensing and can monitor solid-state logic signals. Each light will illuminate once contacts close or voltage is applied to the gate.

##### 1.4.1.1.1 Dry Contacts Open

Timer stops or a continuity indicator goes out at the opening of normally closed contacts, or when conduction through a semiconductor device, such as a triac or a transistor, is interrupted.

##### 1.4.1.1.2 Dry Contacts Close

Timer stops or a continuity indicator glows at the closing of the normally open contacts, or upon conduction through a semiconductor device such as a triac or a transistor.

##### 1.4.1.1.3 Application or Removal of AC or DC voltage

This will either start the Timer or stop the Timer. The continuity indicator will glow (application) or darkens (removal) upon the application or removal of either an AC or DC voltage. To serve a wide range of test applications, the binary inputs have different voltage thresholds. For typical test applications, binary inputs

1 and 2 have a fixed voltage threshold of 5 V. Binary input three has a fixed threshold of 5 V. To monitor TTL signals binary inputs 4 through 6 have a fixed threshold of 3 V. Binary inputs 7 and 8 have fixed thresholds of 5 V, and binary inputs 9 and 10 have fixed threshold of 30 V (for “noisy” test environments). A higher threshold voltage helps to eliminate false triggers due to a noisy source. Lower thresholds allow starting and stopping of timer from TTL voltage signals. The allowable voltage applied is 5 to 300 VAC or 5 to 300 VDC, current limiting resistors provide protection.

1.4.1.1.4 The Timer can be started when turning on any selected generators.

1.4.1.1.5 The Timer can be started simultaneously with a change in Frequency, Phase Angle, or Amplitude. Also, it can be started simultaneously with a Voltage or Current waveform step.

## 1.4.2 Binary Outputs

Binary Outputs 1 and 2 are rated for 300 V at 8 A. Each Binary Output can be configured as normally open or normally closed contacts providing logic to the device under test. Binary Outputs 3 and 4 have a rating of 300 V AC/DC, 8 A and a maximum of 2000 VA breaking capacity (80 W DC), with a response time of less than 10ms. Binary Outputs 5 and 6 are high speed and have an AC/DC voltage rating of 400 V peak, 1 A and a response time typically less than 1ms.

The contacts may be programmed to open or close, thus simulating circuit breaker operation. The programmable wait duration is from 1 ms to 10,000 ms. A fused test lead (fused at 500 mA) is available as an optional accessory to help protect from blowing the internal fuse of binary outputs five & six. The test lead is blue in color so that the user knows it applies to the blue binary outputs. The barrel holder of the test lead is CE marked with a 1000 V, CAT III rating, and marked FUSED 500 mA/1000 V/50 kA.

## 1.5 Battery Simulator



Figure 354 Battery Simulator (BAT SIM)

The SMRT36D includes a battery simulator that provides a variable DC output from 5 to 250 VDC rated at 100 W, 4 A max. User may select from normal setting values of 24, 48, 125, or 250 VDC, or enter the desired output voltage in the window provided, see the STVI Configuration Screen. The output is variable using the STVI Control Knob, or the PC up/down cursor arrows (see the STVI section of the manual).



### CAUTION:

**NOTE: DC voltage is ON and available when the output is turned on using the touch panel or via software command. Do not plug or insert any test lead into the BATTERY SIMULATOR binding posts without first connecting the test leads to the load!**

## 2.0 SETUP

### 2.1 Unpack System

Unpack the unit and check for evidence of any shipping damage. If there is any visual damage, immediately notify the freight carrier to make a damage claim and notify Megger of the damage.



**CAUTION:**

**Potentially lethal voltages may be present on the output terminals. It is highly recommended the operator read the user manual thoroughly and understand the test set operation prior to turning power on.**

2.1.1 Initial Start Up

1. If using RTMS on a PC, connect the **PC/IN** Ethernet Port on the SMRT unit to the PC Ethernet port.
2. Before connecting power to the unit, make sure the POWER ON/OFF Switch is in the OFF position (0). Plug the unit line cord into an appropriate power source and turn the POWER ON/OFF Switch to ON (I). As the SMRT unit goes through its power up sequence, in about a minute the STVI power up screen will appear, then the manual start up screen will appear.

2.2 **Communication Ports**

There are several communication ports. These ports are: two USB, three Ethernet, and an optional Bluetooth wireless port. To connect with Bluetooth, the activation code is 0000 (that is four zeros).

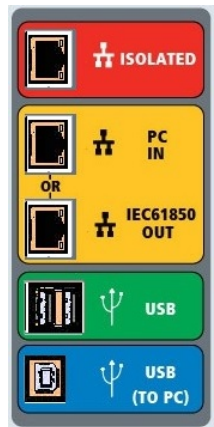
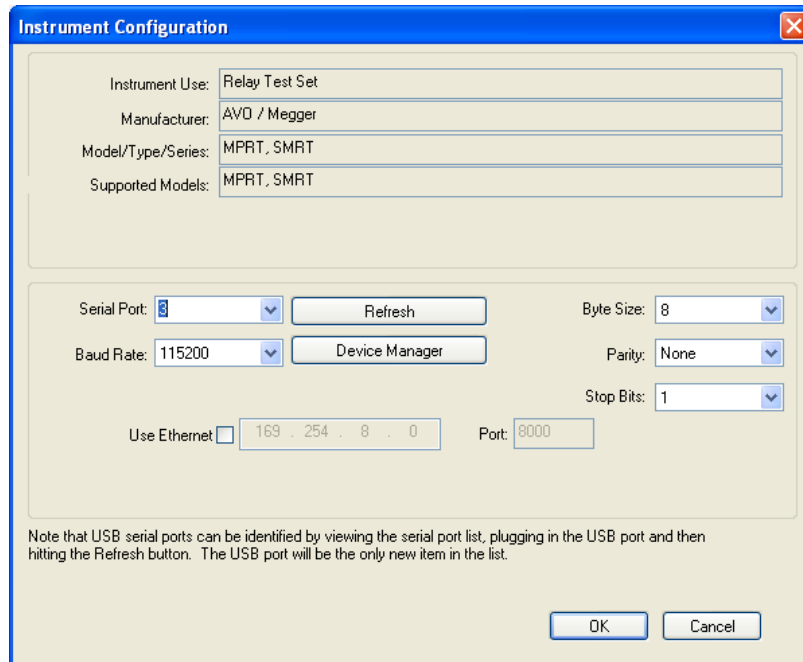

Figure 355 SMRT36D Communication Ports

2.2.1 **USB 2.0 Interface**

The USB Type A ports are intended for use with downloading RTMS, SMRT firmware, or stored PowerDB test results. A USB keyboard or mouse can also be used with the STVI. USB TO PC Interface requires a Type B “downstream” connector and is primarily used as a communication and control port when used with a PC and Megger RTMS or RTMS on a STVI for automated relay testing. It is recommended that you use the Ethernet port for high speed communication and control of the SMRT unit. Using the USB port will require the user to configure the PC com port for USB operation. Clicking on the Instrument Setup icon on

the PowerDB tool bar , the Instrument Configuration Screen (shown in the following figure)



provides the user with access to the PC Device Manager screen. Click on the Device Manager button and navigate to the USB Ports file directory. Since the SMRT36D **defaults to a baud rate of 115,200**, the user will need to configure their USB output com port to match. Returning to the Instrument Configuration screen the user will need to check off the Use Ethernet check box, and set the Baud rate, Byte Size and Stop Bits as shown.

## 2.2.2 PC/IN Ethernet Port

**PC/IN** Ethernet Port is the primary PC connection port for automated relay testing. This port supports MDI/MDI-X auto crossover configuration, which means both standard and “crossover” Ethernet cables may be used. Use this port for standard automated relay testing. This port provides the optimal method for downloading EMTP files, DFR streaming, and updating the unit’s firmware as required. For multiple unit operation, the unit providing the OUT link is providing the primary phase reference to all units “downstream.” For multiple unit operation connect the OUT port to the downstream SMRT unit IN port. RTMS will automatically configure when the units are powered up.

### 2.2.2.1 Setting SMRT IP Address for Operation with a PC

With the Ethernet cable supplied with the unit, connect the **PC/IN** Ethernet Port on the SMRT unit to the PC Ethernet port. Turn the test set on. As the SMRT unit goes through its power up sequence, in less than a minute the STVI power up screen will appear. If using the PC version of RTMS it will auto-detect the SMRT unit connected to the PC. Once it auto-detects the unit, and determines the configuration of the SMRT unit connected, the Manual screen will appear. The unit might not auto detect due to firewall settings. In this case the firewall can be turned off or you can enter the IP address directly using the PowerDB instrument configuration screen by clicking on the Instrument Setup icon on the PowerDB tool

bar . From the Instrument Configuration Screen, shown in the following figure, click off the check mark in the Auto Discover Unit box.

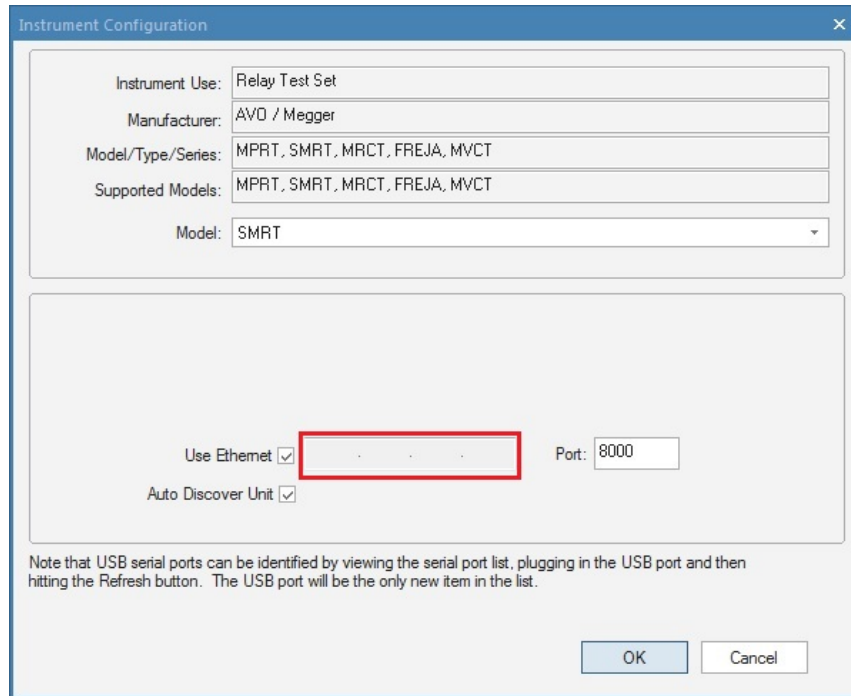

Figure 356 PowerDB Instrument Setup Screen

With the Auto Discover Unit box checked RTMS should find the unit. If not, the IP address can be entered in the box highlighted in the figure above. Also note that the IP address is also printed on the unit nameplate sticker. If the unit is on a network with a DHCP server, the user must use the Auto Discovery mode.

### 2.2.3 ISOLATED Ethernet Port

For IEC 61850 testing connect IEC61850/OUT port to the substation bus or to the relay under test to receive and send GOOSE messages. Connect the ISOLATED port to the PC. When used with the Megger GOOSE Configurator in the RTMS, the SMRT can provide high speed testing of IEC 61850 relays and substations by subscribing to GOOSE messages and mapping to the binary inputs. In addition, it can simulate system conditions such as circuit breaker operation by publishing GOOSE messages mapped to the SMRT binary outputs. With the PC running Megger GOOSE Configurator (MGC) and connected to the ISOLATED port, the operator can “sniff” the substation network from the IEC 61850/OUT port through the ISOLATED port with the SMRT serving as the firewall. With this design the operator cannot accidentally trip off the substation or inflect a PC virus into the substation LAN.

### 2.2.4 IEC61850/OUT Ethernet Port

The IEC 61850/OUT Ethernet Port is a 10/100BaseTX port and is primarily used to interconnect multiple SMRT units together for synchronous multi-unit operation. It is also be used to provide access to the substation IEC 61850 network (when enabled). The SMRT36D with the IEC 61850 option provides selectable priority, VLAN-ID, and meets the IEC 61850-5 standard Type 1A, Class P two-thirds, for high speed trip and reclose simulations. For multiple unit operation, the unit providing the OUT link is providing the primary phase reference to all units “downstream.” With the PC connected to the PC Port, the SMRT and the PC share the same Ethernet network connection, and thus will not have secure isolation from

each other. When testing IEC 61850 devices connect the PC to the ISOLATED Ethernet port to isolate the PC from the IEC 61850 substation bus.

#### 2.2.4.1 Setting SMRT IP Address for Networks or IEC 61850 Operations



The SMRT36D may be controlled over a network. This provides remote control of the SMRT36D over any distance allowing one PC to control at least two units simultaneously, such as in end to end testing. *Connecting the SMRT36D to a Local Area Network or a Wide Area Network could permit unauthorized operation of the unit.*

Through the PC IN Ethernet port, the SMRT36D integrates into a network just like a PC or server. Using this feature requires the user to set up the IP configuration of the SMRT36D for their LAN. Note that the SMRT36D when turned on will automatically search for and acquire a network address if connected to a network. If it fails to automatically acquire an address check to make sure you are properly connected using a standard Ethernet cable. **Do not** use a “cross-over” Ethernet cable (a cross over cable is designed for use from your PC to the test set, not to a network). If the unit still fails to acquire an address, then there may be other issues. This will require assistance from your company’s information management department.

### 3.0 Current Sources

#### 3.1 Parallel Operation

Each SMRT current amplifier can provide 32 A continuous, and up to 60 A for 1.5 s or 90 cycles for testing instantaneous trip elements. When more than 32 A single phase is required for long durations, or 60 A for testing instantaneous elements, two or three current channels may be connected in parallel to provide 60 or 90 A continuous, and up to 120 or 180 A for short durations.

- Note: If an **F** or a **C** appears in the fifth digit of the style identification number (i.e., 30P1F0A0S1) the current returns are floating (isolated from each other and ground). Those units with a style number **G** or **E**, the current returns are common together internally and connected to earth ground.

To parallel the current channels of the unit, perform the following:

If using the sleeved multi-lead current test leads (part number 2008-541), all the black return leads are interconnected together inside the sleeve so they will all share the return current together. Connect each current channel to the relay under test (both red and black terminals to the load). Each Megger test lead is rated 32 A continuous. If using test leads other than those supplied by Megger, ensure that the wire has sufficient size to carry the test current.

! For the earth grounded common return (G or C) units, there is an internal common ground between the current channel return terminals. If using separate individual test leads, all the return leads will need to be common together at the load as shown in the following figure. By not connecting a return lead to all the current channels in use, part or all the return current will be forced through the internal ground. That means with a 3-channel unit up to 180 A could be forced through the internal common ground and may cause damage to the internal common returns. Therefore, it is important that parallel connections must be made at the relay. See the following figure.

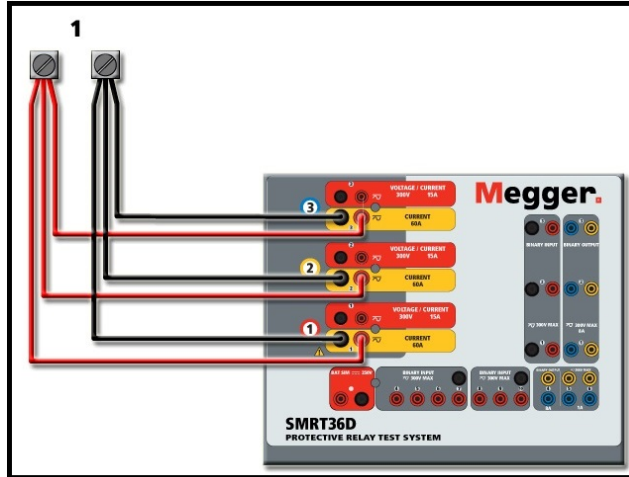

Figure 357 Parallel of All Three Current Outputs

### 3.1.1 Manual Test Screen - Single Phase Up To 180 A

For ease of use and operator convenience, go to the Configuration screen and select the Operating Mode of **3 Voltages – 1 Current @ 180A**. When you return to the manual test screen there will be one current channel displayed, as shown in the following figure.

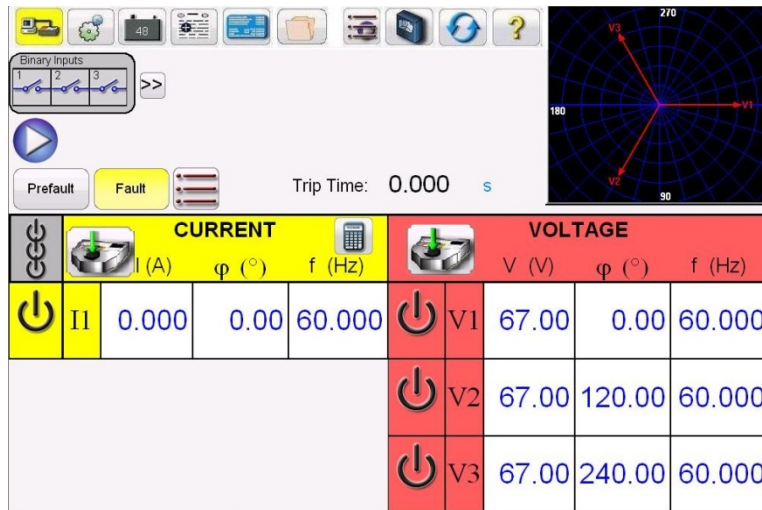

Figure 358 Manual Test Screen – Single Phase Operation

The STVI will automatically set all three currents in phase with each other and divide the current equally between the three current amplifiers. When setting an output, simply enter the value of the desired output current. For example, for an output of 75 A, enter 75, while each current amplifier will be providing 25 A. The current can also be phase shifted. Simply enter the desired phase angle and all three currents will be phase shifted together.

If two current channels are to be used in parallel, leave the unit in the default three phase configuration. Connect the two current outputs to the load as shown in the following figure.

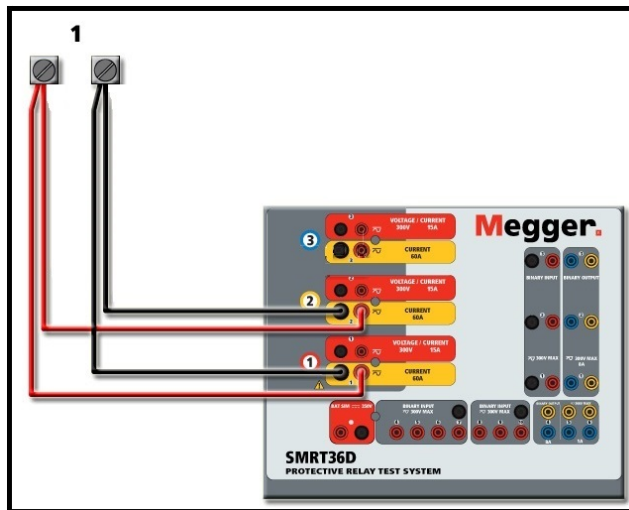



Figure 359 Two Currents in Parallel

Set each channel to one-half of the output requirement. Be sure and **reset current channel #2 to 0 degrees** so that it will be in-phase with current channel #1. With both current channels selected, turn output on by pressing or clicking on the ALL ON/OFF button. Always use the ALL ON/OFF button to turn both current channels on and off together. For manually ramping outputs, if using the PC version of RTMS the  $\uparrow\downarrow$  buttons will be displayed. If using the touch screen, the Control Knob icon  will be displayed. Pressing either of these two will present the user with a window to select the desired level of increment for manually ramping the outputs, the desired channel(s) to be ramped, and what is to be adjusted (amplitude, phase angle or frequency).

### 3.2 Currents in Series Operation

Two current channels may be connected in series to double the available compliance voltage. High impedance electromechanical ground (earth) overcurrent relays have always been difficult to test at high multiples of tap due to the winding impedance and saturation characteristics. The peak voltage required can exceed the maximum output voltage of one SMRT36D current output channel, depending on the required test current. By connecting two current outputs in series, the compliance voltage is doubled, providing higher test currents through the load. There are two methods to series currents together. For the **floating output** (F or C) models connect the two current amplifiers in a “push-push” configuration as shown in the following figure.

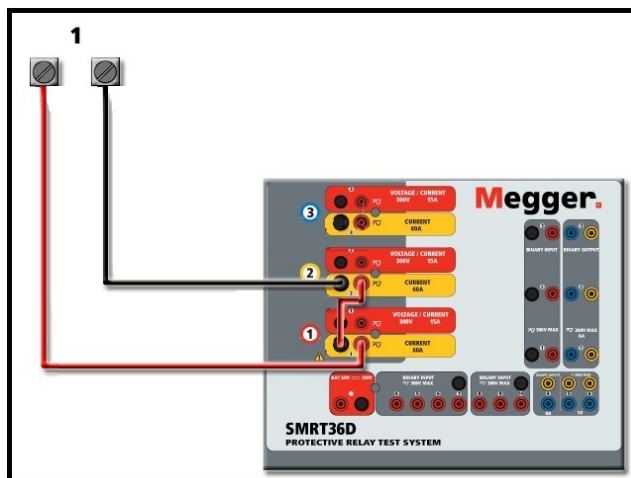



Figure 360 Series Two Currents with Floating Output Unit

The two current channels that are to be used in series set each to the same test current magnitude, and phase angle. Select both current channels and turn output on by pressing or clicking on the ALL ON/OFF button. Always use the ALL ON/OFF button to turn both current channels on and off together. For manually ramping outputs, if using the PC version of RTMS the  $\uparrow\downarrow$  buttons will be displayed. If using the touch screen, the Control Knob icon  will be displayed. Pressing either of these two will present the user with a window to select the desired level of increment for manually ramping the outputs, the desired channel(s) to be ramped, and what is to be adjusted (amplitude, phase angle or frequency).

To series the current channels of the **common grounded returns** (G or E) unit, perform the following: Using the current channel test leads, connect the Red output terminals of the two current channels to the relay under test. Even though the two returns associated with the current channels are connected internally with the common returns, place a jumper as shown. This will ensure that the internal common leads will not be damaged.

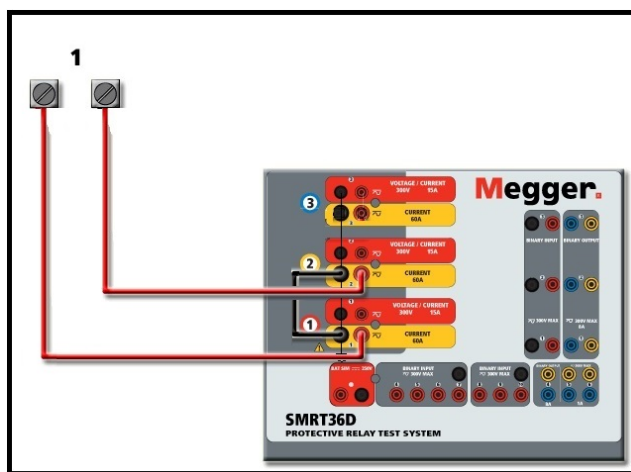



Figure 361 Series of Two Current Channels with Grounded Common Returns

- NOTE: One current channel should be set to 0 degrees and the other current channel should be set to a phase angle of 180 degrees so that the two compliance voltages add across the load. DO NOT attempt to series more than two currents together on a grounded common returns unit.

The two current channels that are to be used in series set each to the same test current magnitude. Initiate the two current channels simultaneously by pressing the ALL ON/OFF button. Always use the ALL ON/OFF button to turn both current channels on and off together. For manually ramping outputs, if using the PC version of RTMS the  $\uparrow\downarrow$  buttons will be displayed. If using the touch screen, the Control Knob icon  will be displayed. Pressing either of these two will present the user with a window to select the desired level of increment for manually ramping the outputs, the desired channel(s) to be ramped, and what is to be adjusted (amplitude, phase angle or frequency).

#### 4.0 Voltage Sources

##### 4.1 Outputs Summed Together

Two voltage channels may be used to sum the voltage outputs to obtain higher than rated voltage provided the load is ungrounded. Connect the load between the voltage channel posts, set  $V_1$  Phase to  $0^\circ$  and set  $V_2$  Phase to  $180^\circ$ . The voltage outputs will add so the total voltage is the sum of the two voltage amplitudes,  $V_1$  and  $V_2$  as can be seen in the following figures.

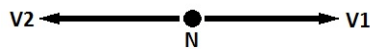

 Note: If an **F** or **C** appears in the 5<sup>th</sup> digit of the style identification number (i.e., 30P1**F**0A0S1) the voltage returns are **floating** (isolated from each other and ground). Those units with a style number **G** or **E** the voltage returns are **common together internally and connected to earth ground**.

For the **floating common** units, the user must connect the associated voltage channels black common returns together, when series operation is required (see the following figures). Remove external commons when testing is completed. DO NOT attempt to series more than two voltage channels together.

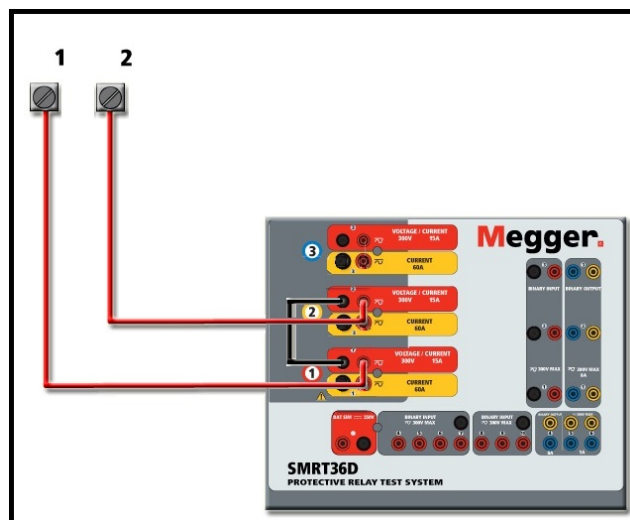

Figure 362 Series of Voltage Channels for **Floating Ungrounded Common Returns**

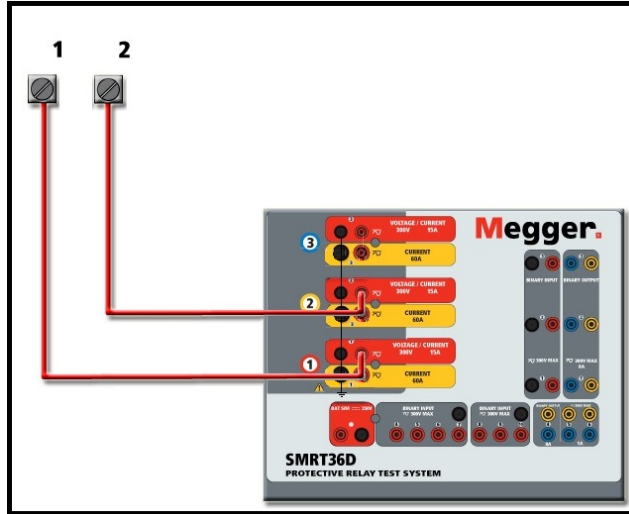

Figure 363 Series of Voltage Channels with Grounded Common Returns

#### 4.2 3Ø, 3-Wire, Open-Delta, and T-Connection

See section 3.4.2 in RTMS for detailed descriptions and use of the Open-Delta and T-Connection.

##### 4.2.1 Balanced Open Delta

The Open-Delta configuration is easy to use when a balanced three-phase source is required because the amplitude and phase relationship can be set directly. No calculations are necessary. When using the Open-Delta configuration, it is suggested to use voltage channel #1, designated  $V_1$ , and voltage channel #2, designated  $V_2$ , while the COMMON binding post is designated  $V_g$ . With this arrangement, the magnitude and phase angle of the potentials can be easily calculated and set. For the balanced three-phase condition  $V_{1g}$  and  $V_{2g}$  are equal in magnitude and separated by an angle of  $60^\circ$ . This is done by setting the  $V_1$  and  $V_2$  potentials equal in magnitude, setting  $0^\circ$  on  $V_1$  and  $300^\circ$  ( $60^\circ$  leading assuming that the default phase rotation is set to  $360^\circ$  Lag) on  $V_2$ , see the following figure.

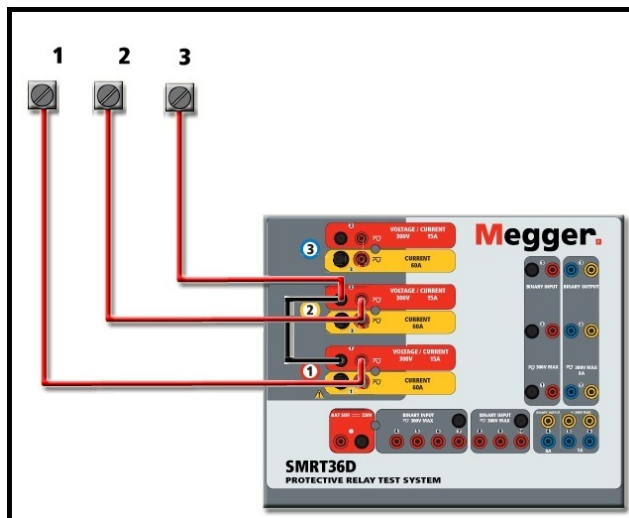

Figure 364 Three Phase Open Delta Connections

#### 4.2.2 T Connection

The second method of obtaining a three-phase, three-wire voltage source is the so-called T-Connection. The method, shown in the following figure, is easier to use when obtaining an unbalanced, phase - to -phase fault simulation since it eliminates calculations. To reduce confusion when using the T-Connection, the voltage output #1 is designated  $V_a$  and its phase angle set at  $0^\circ$ , voltage output #2 is designated  $V_b$  and its phase angle set for  $180^\circ$ , and voltage output #3 is designated  $V_c$  and its phase angle is set for  $270^\circ$ . Any combination of balanced three phase faults or unbalanced phase-to-phase fault conditions can be easily simulated. The following figure indicates these phase relationships.

**!** NOTE: This method should not be used for low fault voltages, or used on solid state relays that may be sensitive to this type of connection (i.e., 5 volts or less, or for testing ABB or Westinghouse type SKD relays).

#### 4.3 $3\phi$ , 4-Wire, Y-Connection

A three-phase, four-wire potential system can be provided using three output modules. The vector relationships are referenced below. This Y-Connection has the advantage of being able to supply a higher line-to-line voltage ( $1.73 \times$  phase-to-neutral voltage). It is ideally suited for simulating phase-to-ground faults. Voltage channel #1 is designated as  $V_a$  with its phase relationship set for  $0^\circ$ . Voltage channel #2 is then designated as  $V_b$  and phase angle set for  $120^\circ$ . Finally, voltage channel #3 is designated  $V_c$  and phase angle set for  $240^\circ$  (for a 1-2-3 counterclockwise rotation).  $V_a$ ,  $V_b$  and  $V_c$  are connected to the voltage potential binding posts on the respective test sets.

**!** Note: If an **F** or **C** appears in the 5<sup>th</sup> digit of the style identification number (i.e., 30P1**F**0A0S1) the voltage returns are floating (isolated from each other and ground). Those units with a style number **G** or **E** the voltage returns are common together internally and connected to earth ground.

If using the sleeved multi-lead voltage test leads (part number 2001-395), all the black return leads are interconnected together inside the sleeve so they will all share the return together. Therefore, only one return lead is provided on the relay connection side of the sleeved leads (like the connections in the following figure).

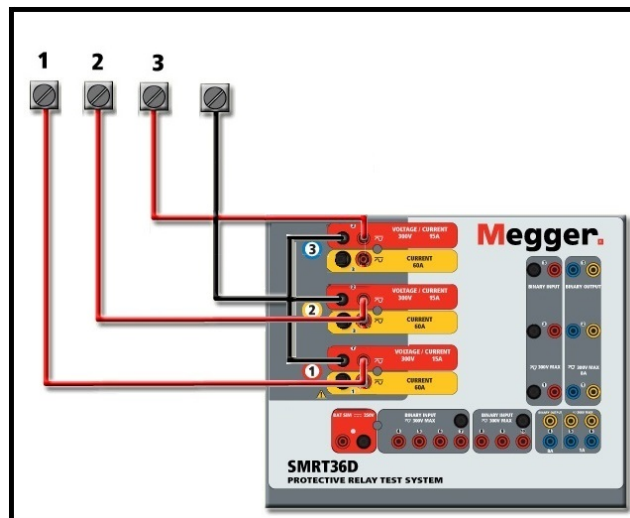

Figure 365 Three Phase Four Wire Test Connections

- For the earth grounded common return (G or E) units, there is an internal common ground between the voltage and current channel return terminals. Therefore, only one return lead is required for the voltage channels. If using separate individual test leads, for the floating common units the user must connect the associated voltage channels black common returns together as shown above.

# Addendum E



**Model SMRT43D/46D.  
Megger Relay Tester**

## 1.0 Operation

The unit's design is a "modular" concept. All inputs and outputs are clearly marked and logically grouped so continual reference to the instruction manual should not be necessary once the operator is acquainted with the test system. The unit's Top Panel will appear different among units, since each unit may have up to three optional Voltage/Current Generator (VIGEN) Modules installed.

### 1.1 General Description

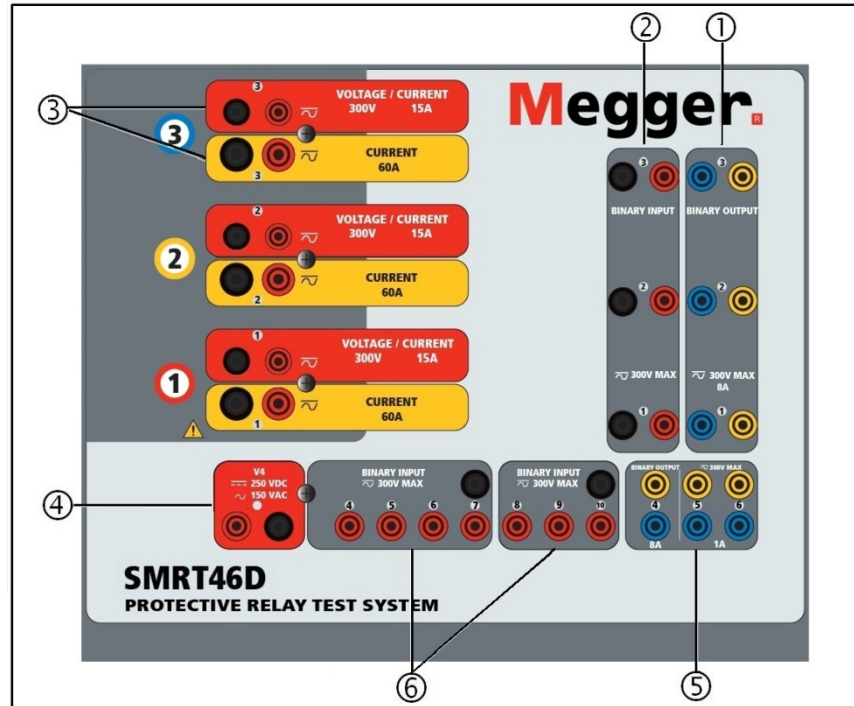

Figure 366 Top Panel SMRT46D (Pictured with Floating Returns Option)

#### 1.1.1 Top Panel

7. ① **Binary Outputs**<sup>8</sup> – the first three VIGEN modules include Binary Inputs and Binary Outputs. Therefore, with a minimum 2 channel unit there are 2 Binary Outputs located on the top panel (numbered 1 and 2). The 3<sup>rd</sup> Binary Output will be replaced with DC Input terminals if ordering the unit with the Transducer option. Each Binary Output can be configured as Normally Open or Normally Closed contacts providing logic to the device under test. The Binary Outputs 1, 2, and 3 can switch up to 300 VAC or 250 VDC with 8 A continuous. The programmable wait duration is from 1 ms to 10,000 ms.
8. ② **Binary Inputs**<sup>9</sup> – with a minimum 2 channel unit there are 2 Binary Inputs located on the top panel. The 3<sup>rd</sup> Binary Input will be replaced with DC Input terminals if ordering the unit with the Transducer option. To serve a wide range of test applications the binary inputs have different voltage thresholds. Depending on the age of the unit, for typical test applications, binary inputs 1 and 2 may have programmable voltage thresholds from 2 to 150 V. Older units will have a fixed voltage threshold of 5 V. Binary input 3 has a fixed

<sup>8</sup> If ordering the optional Transducer test feature the number of Binary Outputs and Inputs is reduced by 1

threshold of 5 V. For **GPS End-to-End synchronized relay testing Binary 1** may relate to a remote trigger pulse from a GPS satellite receiver for external initiation, or the input of an **IRIG-B** signal (see use of **Wait IRIG-B** input using the STVI Sequencer test). There are an additional 7<sup>1</sup> binary inputs. To monitor TTL signals binary inputs 4 through 6 have a fixed threshold of 3 V. Binary inputs 7 and 8 have fixed thresholds of 5 V, and binary inputs 9 and 10 have fixed threshold of 30 V (for “noisy” test environments). In addition to serving as Timer/Monitor inputs, the Binary Inputs may be programmed to trigger binary output sequence(s). Binary Inputs can also be programmed using Boolean logic for more complex power system simulations.



9. ③ **Voltage/Current Generator Module (or VIGEN)** –There are three available slots for the VIGEN Modules. The slots are numbered 1 to 3 from bottom to top, with the topmost VIGEN numbered 3. The three phase voltages and currents are noted by the red and yellow surrounding each output channel. Phases A, B and C Voltage Channels (V1, V2 and V3) are denoted by the red color. Phases A, B and C Current Channels (I1, I2 and I3) are denoted by the yellow color. When the voltage generators are converted to current generators, they will change on the STVI display as V1 = I4, V2 = I5 and V3 = I6. For more details on the VIGEN output capabilities see section 1.4.
  
10. ④ **AC/DC AUX (V4) Output** – the SMRT46D provides an AC/DC AUX Voltage Output with a continuously variable dc output voltage from 10 to 250 V, at 100 W (3.33 A Max) providing logic voltage for solid-state relays, or use as a reference ac voltage source for synchronizing or polarization potential from 0 – 150 V, 100 VA. When powered ON, the LED above the output terminals illuminates.
  
11. ⑤ **Binary Outputs** – additional Binary Outputs can be configured as Normally Open or Normally Closed contacts providing logic to the device under test. Binary Output 4 has an AC Rating of 400 V max., I<sub>max</sub>: 8 A, 2000 VA maximum breaking capacity, and a DC Rating of 300 V max., I<sub>max</sub>: 8 A, 80 W, with a Response Time: < 10ms. **Binary Outputs 5 and 6 are high speed** and have an AC/DC Voltage Rating of 400 V peak, I<sub>max</sub>: 1 A, with a Response Time: < 1ms typical. The programmable wait duration is from 1 ms to 10,000 ms. An LED directly above the terminals indicates the status of the contact. ON indicates closed, and OFF indicates open.
  
12. ⑥ **Binary Inputs** – additional, independent, galvanically isolated, Start/Stop or Monitor circuits to monitor operation of relay contacts or trip SCR. Continuity light is provided for each input gate. Upon sensing continuity, or voltage applied, the lamp will glow. In addition to serving as wet/dry contacts the Binary Inputs may be programmed to trigger binary output sequence(s). Binary Inputs can also be programmed using Boolean logic for more complex power system simulations. The Binary Inputs will accept a voltage range of 5 to 300 VAC or 5 to 250 VDC, or dry Normally Open/Normally Closed contacts.

### 1.1.2 Front Panel:

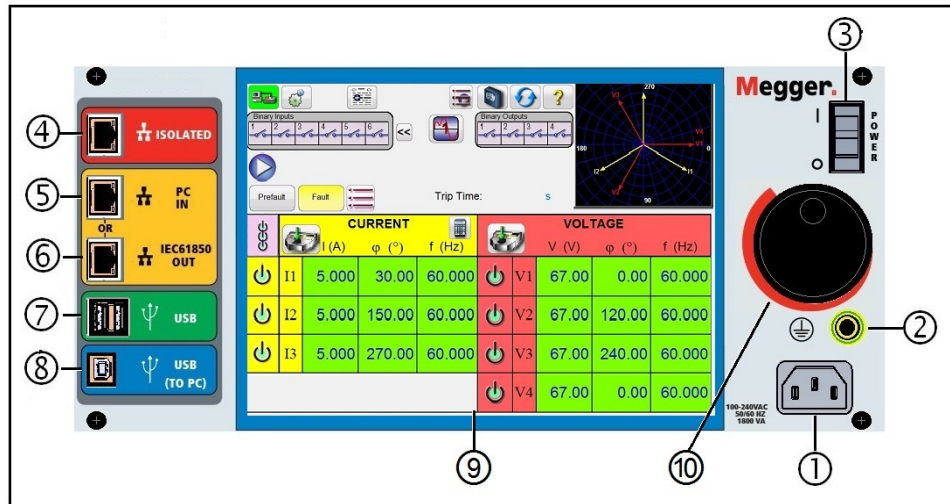

Figure 367 SMRT46D Front Panel

1. **Incoming Power/Line Cord** ① – the input line cord, ground terminal, are mounted on the front panel of the test set.

#### Input Line Cord



The test set is equipped with a line cord, which connects to the male connector on the front panel. Verify the input voltage rating on the front panel before connecting the line cord to the power source.

2. **Earth Ground Jack** ② – use this terminal to connect chassis ground to earth ground.



A chassis ground (earth) point on the front panel is provided as an additional safety ground.

3. **POWER ON/OFF Switch** ③ – used to switch unit on and off.
4. **ISOLATED** ④ For IEC 61850 testing connect IEC61850/OUT port to the substation bus or to the relay under test to receive and send GOOSE messages. Connect the ISOLATED port to the PC. When used with the Megger GOOSE Configurator in RTMS, the SMRT can provide high speed testing of IEC 61850 relays and substations by subscribing to GOOSE messages and mapping to the binary inputs. In addition, it can simulate system conditions such as circuit breaker operation by publishing GOOSE messages mapped to the SMRT binary outputs. With the PC running Megger GOOSE Configurator (MGC) and connected to the ISOLATED port, the operator can “sniff” the substation network from the IEC 61850/OUT port through the ISOLATED port with the SMRT serving as the firewall. With this design the operator cannot accidentally trip off the substation or inflect a PC virus into the substation LAN.
5. **PC/IN** ⑤ Ethernet Port is the primary PC connection port for automated relay testing. This port supports MDI/MDI-X auto crossover configuration, which means both standard

and “crossover” Ethernet cables may be used. Use this port for standard automated relay testing. This port provides the optimal method for downloading EMTP files, DFR streaming, and updating the unit’s firmware as required. For multiple unit operation, the unit providing the OUT link provides the primary phase reference to all units “downstream.” For multiple unit operation connect the OUT port to the downstream SMRT unit IN port. RTMS will automatically configure when the units are powered up.

6. **IEC61850/OUT** ⑥ Ethernet Port is a 10/100BaseTX port and is primarily used to interconnect multiple SMRT units together for synchronous multi-unit operation. It is also used to provide access to the substation IEC 61850 network. For multiple unit operation, the unit providing the OUT link provides the primary phase reference to all units “downstream.” With the PC connected to the PC Port, the SMRT and the PC share the same Ethernet network connection, and thus will not have secure isolation from each other. When testing IEC 61850 devices connect the PC to the ISOLATED Ethernet port to isolate the PC from the IEC 61850 substation bus.
7. **USB Interface** ⑦ There is two type A ports available. This port is primarily used to update the firmware in the SMRT as well as update RTMS onboard using a USB memory stick. It may also be used to download test results from the SMRT for download onto another PC with PowerDB software for storage or printing. In addition, the user can use a USB keyboard, as well as a mouse, in conjunction with the STVI. Keyboard and/or mouse are not provided with accessories.
8. **USB (TO PC) Interface** ⑧ – The (TO PC) USB Interface requires a Type B “downstream” connector and is primarily used as a communication and control port when used with a PC and Megger RTMS for automated relay testing. A USB cable is not provided with the test set or in the optional accessories. For computer control, an Ethernet cable is provided. However, should the user desire to use the USB port any standard USB A/B cable will work with the unit. May be used when isolation is required for a secure substation access between the SMRT and the IEC 61850 substation network.

## 1.2 Input Power

The input voltage rating may be from 100 to 240 VAC,  $\pm 10\%$ , 50/60 H. Input current required varies with the number of output modules in use, load, and input voltage value. With three VIGENS, the maximum input power is 1800VA. The input is protected by a power ON/OFF switch/circuit breaker.

### 1.2.1 Input Power Cord

Depending on the country, the power cord can come with a NEMA 5-15 male connector, a CEE 7/7 Schuko two prong connector, with International Color Coded pig-tail wires (light blue, brown and green with yellow stripe) with the insulation jacket stripped ready for installation of the appropriate male connector, or with UK power cord.

Model SMRT46D X0XXXXAXXX comes with a North American power cord (part number 620000).

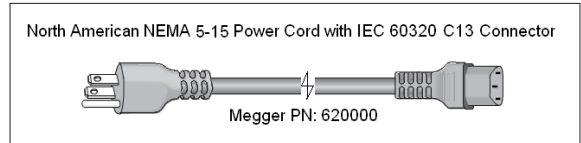

Model SMRT46D **X0XXXXEXXX** comes with a Continental Europe power cord (part number 50425).

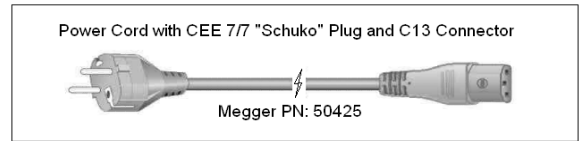

Model SMRT46D **X0XXXXIXXX** comes with an International Color Code power cord. The cord, part number 15065, is ready for wiring to the appropriate plug (depending on country). The following colors apply, Brown = Line, Blue = Neutral and Green/Yellow = Ground.

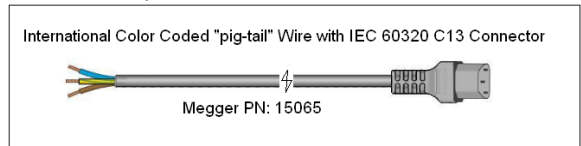

Model SMRT46D **X0XXXXUXXX** comes with a UK power cord (part number 90002-989).



### 1.3 Voltage - Current Generator (VIGEN) Module

Voltages and Currents are noted by the red and yellow surrounding each output channel. Phases 1, 2 and 3 voltage channels are denoted by the red color. Phases 1, 2 and 3 current channels are denoted by the yellow color. All outputs are independent from sudden changes in mains voltage and frequency and are regulated so changes in load impedance do not affect the output. Standard amplifier outputs are isolated or floating. The SMRT units can be ordered with the amplifier common returns tied to chassis ground as an option.

#### 1.3.1. Convertible Voltage/Current Amplifier

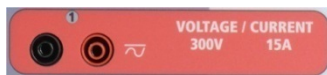

The SMRT PowerV™ voltage amplifier provides a flat power curve from 30 to 150 V in the 150 V range to permit testing of high current applications such as panel testing.

<b>Voltage Range</b>	<b>Power/Current (Max)</b>
30.00 V	150 VA @ 5.0 A
150.00 V	150 VA Constant Output Power from 30 to 150 V
300.00 V	150 VA @ 0.5 A

### Voltage Amplifier in Current Mode :

The voltage amplifier is convertible to a current source with the following output capability. Output power ratings are specified in RMS values and peak power ratings.

Note: the SMRT43D voltage channels are not convertible to currents

Output Current	Power	Max V	Duty Cycle
5 A	150 VA (212 peak)	30.0 V RMS	Continuous
15 A	120 VA	8.0 V RMS	1.5 s or 90 cycles

With a 3 channel SMRT unit, convertible channels in conjunction with the three main current channels, provides 6 currents for testing three phase current differential relays. When the voltage generators are converted to current generators, they will change on the STVI display as current phases 4, 5 and 6.

 The voltage amplifier output is protected from short circuits and thermally protected against prolonged overloads. In case of a short circuit or a thermal overload, the amplifier will automatically turn off, and if the STVI is connected a message to the user will be displayed indicating which condition exists.

### 1.3.2. Current Amplifier



The SMRT current amplifier Constant Power Output feature delivers maximum compliance voltage to the load constantly during the test, and range changing is done automatically, on-the-fly, under load. This ensures better test results, saves time by not having to turn the outputs off to change output taps or ranges, and unlike single range current amplifiers insures a higher compliance voltage at lower test currents. Constant Power Output in many cases eliminates the need to parallel or series current channels together to test high burden relays.

The following are typical output current and associated available compliance voltage values. The per channel output current and power ratings are specified in AC RMS values and peak power ratings. Specified duty cycles are based upon typical room ambient temperature.

Output Current	Power	Max V/Duty Cycle
1 A	15 VA	15.0 V RMS Continuous
4 A	200 VA (282 peak)	50.0 V RMS Continuous
15 A	200 VA (282 peak)	13.4 V RMS Continuous
32 A	200 VA (282 peak)	6.25 V RMS Continuous
45 A <sup>9</sup>	319 VA (424 peak)	6.67 V RMS 1.5 s or 90 cycles
60 A	319 VA (424 peak)	5.00 V RMS 1.5 s or 90 cycles
DC 200 W		

 The current amplifier output is protected from open circuits and thermally protected against prolonged overloads. In case of an open circuit or a thermal overload, the amplifier will

<sup>9</sup> The SMRT43D is limited to 45 A for 1.5 s or 90 cycles

automatically turn off, and if the STVI is connected a message to the user will be displayed indicating which condition exists.

## 1.4 Binary Inputs and Outputs



Figure 368 Binary Inputs and Outputs 1 and 2

Binary Inputs and Outputs are clearly marked and logically grouped. The unit's Top Panel will appear different among units, which means Binary Input/Output 1 will always be occupied, while Binary Input/Output 2 may, nor may not, depending on the configuration. If the Transducer option is installed Binary Input/Output 3 will be replaced by the DC Input terminals, with a different overlay. The Binary Inputs are used to monitor relay trip contacts for performing pickup and dropout tests as well as for performing timing functions. The Binary Outputs are used to simulate normally open/normally closed contacts for testing breaker failure schemes, or similar power system operations. In addition, they may also be used to switches AC/DC voltages and currents.



Figure 369 Binary Inputs 4 to 10 and Binary Outputs 4 to 6

### 1.4.1 Binary Inputs

The binary inputs are specifically designed to measure high speed operation of electro-mechanical, solid-state, and microprocessor-based protection relays. All binary Inputs default to Monitor Mode, Contact change of state, latched OFF. If using RTMS to change a binary input from Contact change of state to Voltage Applied/Removed click on or touch the Input Type window and a sine wave will appear where the Contact icon was indicating. The input is now set for voltage sensing.

To change the binary input from Monitor mode to Timer Mode, click on or touch the Use as Monitor button and the display window will change to show Use as Trip, Latched, meaning the binary input is now set to stop the timer upon sensing the first contact closure (if the Input Type is set for contact) or upon sensing voltage if the Input Type is set to Voltage Sensing.

#### 1.4.1.1 Start, Stop, and Monitor Gates

In the SMRT43D/46D there are up to ten<sup>1</sup> identical, independent, programmable gate circuits that permit simple selection of the desired mode for timing or contact monitoring operation. To monitor operation of the contacts or trip SCR in the device under test, a light is provided for each gate. The gate circuit is isolated for voltage-sensing and can monitor solid-state logic signals. Each light will illuminate once contacts close or voltage is applied to the gate.

#### 1.4.1.1.1 Dry Contacts Open

Timer stops or a continuity indicator goes out at the opening of normally closed contacts, or when conduction through a semiconductor device, such as a triac or a transistor, is interrupted.

#### 1.4.1.1.2 Dry Contacts Close

Timer stops or a continuity indicator glows at the closing of the normally open contacts, or upon conduction through a semiconductor device such as a triac or a transistor.

#### 1.4.1.1.3 Application or Removal of AC or DC voltage

This will either start the Timer or stop the Timer. The continuity indicator will glow (application) or darkens (removal) upon the application or removal of either an AC or DC voltage. To serve a wide range of test applications the binary inputs have different voltage thresholds. Depending on the age of the unit, for typical test applications, binary inputs 1 and 2 may have programmable voltage thresholds from 2 to 150 V. Older units will have a fixed voltage threshold of 5 V AC/DC. Binary input 3 has a fixed threshold of 5 V. To monitor TTL signals binary inputs 4 through 6 have a fixed threshold of 3 V. Binary inputs 7 and 8 have fixed thresholds of 5 V, and binary inputs 9 and 10 have fixed threshold of 30 V (for “noisy” test environments). A higher threshold voltage helps to eliminate false triggers due to a noisy source. Lower thresholds allow starting and stopping of timer from TTL voltage signals. The allowable voltage applied is 5 to 300 VAC or 5 to 300 VDC, current limiting resistors provide protection.

1.4.1.1.4 The Timer can be started when turning on any selected generators.

1.4.1.1.5 The Timer can be started simultaneously with a change in Frequency, Phase Angle, or Amplitude. Also, it can be started simultaneously with a Voltage or Current waveform step.

#### 1.4.2 Binary Outputs

Binary Outputs 1 and 2 are rated for 300 V at 8 A. Each Binary Output can be configured as normally open or normally closed contacts providing logic to the device under test. Binary Outputs 3 and 4 have a rating of 300 V AC/DC, 8 A and a maximum of 2000 VA breaking capacity (80 W DC), with a response time of less than 10ms. Binary Outputs 5 and 6 are high speed and have an AC/DC voltage rating of 400 V peak, 1 A and a response time typically less than 1ms.

The contacts may be programmed to open or close, thus simulating circuit breaker operation. The programmable wait duration is from 1 ms to 10,000 ms. A fused test lead (fused at 500 mA) is available as an optional accessory to help protect from blowing the internal fuse of binary outputs 5 & 6. The test lead is blue in color so that the user knows it applies to the blue binary outputs. The barrel holder of the test lead is CE marked with a 1000 V, CAT III rating, and marked FUSED 500 mA/1000 V/50 kA.

#### 1.5 AC/DC AUX Output (V4)

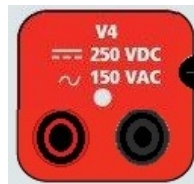

Figure 370 AC/DC AUX V4 Output Terminal

The SMRT43D and 46D includes an AC/DC Auxiliary Output that provides a variable DC output from 5 to 250 VDC rated at 100 W, 3.33 A max. User may select from normal setting values of 24, 48, 125, or 250 VDC, or enter the desired output voltage in the window provided, see RTMS Configuration Screen. Source may also be used as a synchronizing or polarization voltage providing 0 – 150 Volts AC at 100 VA. The output is variable using the STVI Control Knob, or the PC up/down cursor arrows (see the STVI section of the manual).



**CAUTION:**

**NOTE: DC voltage is ON and available when the output is turned on using the touch panel or via software command. Do not plug or insert any test lead into the V4 binding posts without first connecting the test leads to the load!**

2.0 **SETUP**

2.1 Unpack System

Unpack the unit and check for evidence of any shipping damage. If there is any visual damage, immediately notify the freight carrier to make a damage claim and notify Megger of the damage.



**CAUTION:**

**Potentially lethal voltages may be present on the output terminals. It is highly recommended the operator read the user manual thoroughly and understand the test set operation prior to turning power on.**

2.1.1 Initial Start Up

1. If using RTMS on a PC, connect the **PC/IN** Ethernet Port on the SMRT unit to the PC Ethernet port.
2. Before connecting power to the unit, make sure the POWER ON/OFF Switch is in the OFF position (O). Plug the unit line cord into an appropriate power source and turn the POWER ON/OFF Switch to ON (I). As the SMRT unit goes through its power up sequence, in about a minute the STVI power up screen will appear, then the manual start up screen will appear.

2.2 **Communication Ports**

There are several communication ports. These ports are: two USB, three Ethernet, and an optional Bluetooth wireless port. To connect with Bluetooth, the activation code is 0000 (that is four zeros).

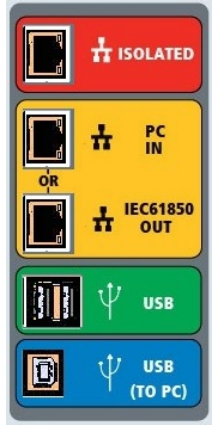

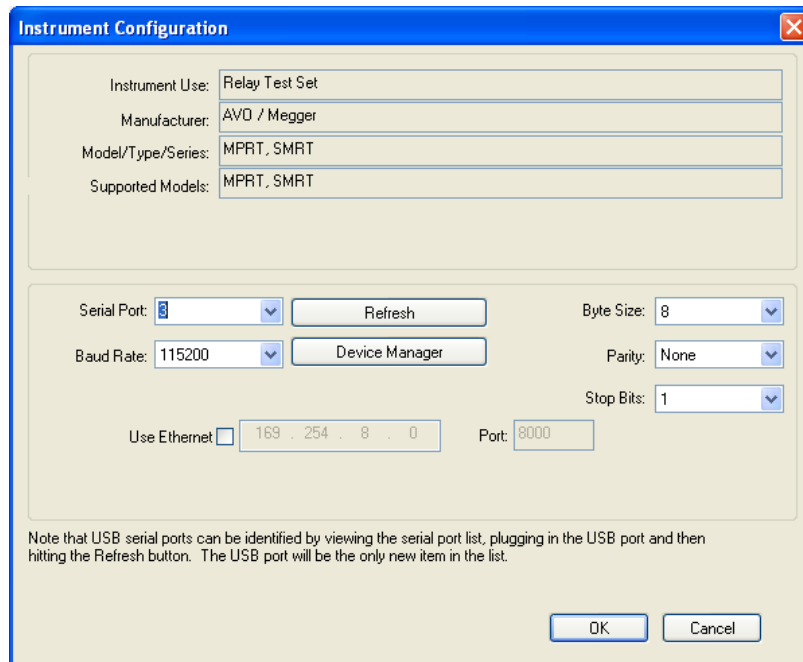

Figure 371 SMRT46D Communication Ports

### 2.2.1 USB 2.0 Interface

The USB Type A ports are intended for use with downloading RTMS, SMRT firmware, or stored PowerDB test results. A USB keyboard or mouse can also be used with the STVI. USB TO PC Interface requires a Type B “downstream” connector and is primarily used as a communication and control port when used with a PC and Megger RTMS or RTMS on the STVI for automated relay testing. It is recommended that you use the Ethernet port for high speed communication and control of the SMRT unit. Using the USB port will require the user to configure the PC com port

for USB operation. Clicking on the Instrument Setup icon on the PowerDB tool bar , the Instrument Configuration Screen (shown in the following figure)



provides the user with access to the PC Device Manager screen. Click on the Device Manager button and navigate to the USB Ports file directory. Since the SMRT46D **defaults to a baud rate of 115,200**, the user will need to configure their USB output com port to match. Returning to the

Instrument Configuration screen the user will need to check off the Use Ethernet check box, and set the Baud rate, Byte Size and Stop Bits as shown.

### 2.2.2 PC/IN Ethernet Port

**PC/IN** Ethernet Port is the primary PC connection port for automated relay testing. This port supports MDI/MDI-X auto crossover configuration, which means both standard and “crossover” Ethernet cables may be used. Use this port for standard automated relay testing. This port provides the optimal method for downloading EMTP files, DFR streaming, and updating the unit’s firmware as required. For multiple unit operation, the unit providing the OUT link provides the primary phase reference to all units “downstream.” For multiple unit operation connect the OUT port to the downstream SMRT unit IN port. RTMS will automatically configure when the units are powered up.

#### 2.2.2.1 Setting SMRT IP Address for Operation with a PC

With the Ethernet cable supplied with the unit, connect the **PC/IN** Ethernet Port on the SMRT unit to the PC Ethernet port. Turn the test set on. As the SMRT unit goes through its power up sequence, in less than a minute the STVI power up screen will appear. If using the PC version of RTMS it will auto-detect the SMRT unit connected to the PC. Once it auto-detects the unit, and determines the configuration of the SMRT unit connected, the Manual screen will appear. The unit might not auto detect due to firewall settings. In this case the firewall can be turned off or you can enter the IP address directly using the PowerDB instrument configuration screen by clicking

on the Instrument Setup icon on the PowerDB tool bar . From the Instrument Configuration Screen, shown in the following figure, click off the check mark in the Auto Discover Unit box.

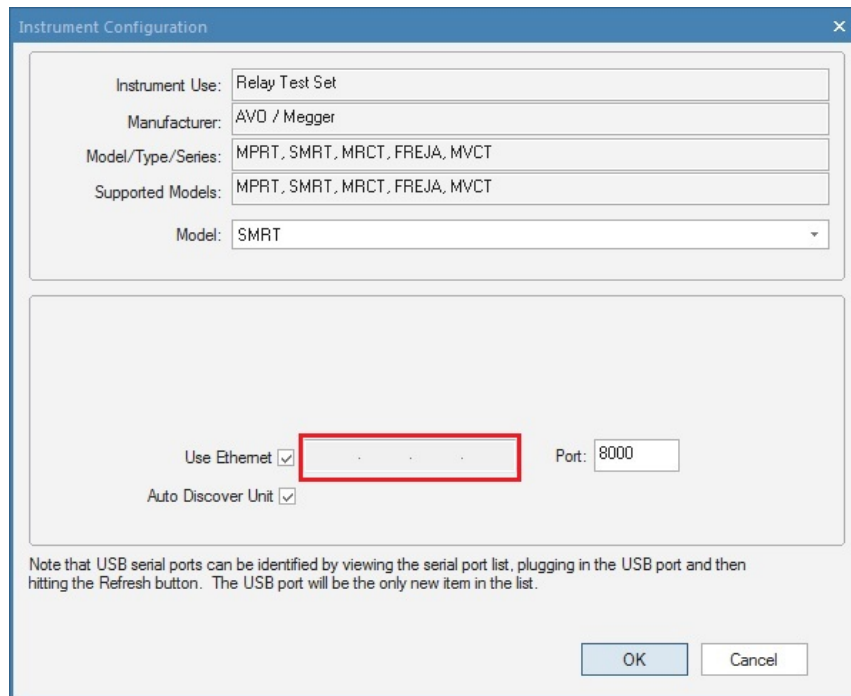

Figure 372 PowerDB Instrument Setup Screen

With the Auto Discover Unit box checked RTMS should find the unit. If not, the IP address can be entered in the box highlighted in the figure above. Also note that the IP address is also printed on

the unit nameplate sticker. If the unit is on a network with a DHCP server, the user must use the Auto Discovery mode.

### 2.2.3 ISOLATED Ethernet Port

For IEC 61850 testing connect IEC61850/OUT port to the substation bus or to the relay under test to receive and send GOOSE messages. Connect the ISOLATED port to the PC. When used with the Megger GOOSE Configurator software, the SMRT can provide high speed testing of IEC 61850 relays and substations by subscribing to GOOSE messages and mapping to the binary inputs. In addition, it can simulate system conditions such as circuit breaker operation by publishing GOOSE messages mapped to the SMRT binary outputs. With the PC running Megger GOOSE Configurator and connected to the ISOLATED port, the operator can “sniff” the substation network from the IEC 61850/OUT port through the ISOLATED port with the SMRT serving as the firewall. With this design the operator cannot accidentally trip off the substation or inflict a PC virus into the substation LAN.

### 2.2.4 IEC61850/OUT Ethernet Port

The IEC 61850/OUT Ethernet Port is a 10/100BaseTX port and is primarily used to interconnect multiple SMRT units together for synchronous multi-unit operation. It is also be used to provide access to the substation IEC 61850 network (when enabled). The SMRT46D with the IEC 61850 option provides selectable priority, VLAN-ID, and meets the IEC 61850-5 standard Type 1A, Class P 2/3, for high speed trip and reclose simulations. For multiple unit operation, the unit providing the OUT link is providing the primary phase reference to all units “downstream.” With the PC connected to the PC Port, the SMRT and the PC share the same Ethernet network connection, and thus will not have secure isolation from each other. When testing IEC 61850 devices connect the PC to the ISOLATED Ethernet port to isolate the PC from the IEC 61850 substation bus.

#### 2.2.4.1 Setting SMRT IP Address for Networks or IEC 61850 Operations



The SMRT43D or 46D may be controlled over a network. This provides remote control of the SMRT unit over any distance allowing one PC to control at least two units simultaneously, such as in end to end testing. *Connecting the SMRT43D or 46D to a Local Area Network or a Wide Area Network could permit unauthorized operation of the unit.*

Through the PC IN Ethernet port, the SMRT36D/46D integrates into a network just like a PC or server. Using this feature requires the user to set up the IP configuration of the SMRT43D/46D for their LAN. Note that the SMRT43D/46D when turned on will automatically search for and acquire a network address if connected to a network. If it fails to automatically acquire an address check to make sure you are properly connected using a standard Ethernet cable. **Do not** use a “cross-over” Ethernet cable (a cross over cable is designed for use from your PC to the test set, not to a network). If the unit still fails to acquire an address, then there may be other issues. This will require assistance from your company’s information management department.

## 3.0 Current Sources

### 3.1 Parallel Operation

Each SMRT46D current amplifier can provide 32 A continuous, and up to 60 A for 1.5 s or 90 cycles for testing instantaneous trip elements. When more than 32 A single phase is required for long durations, or 60 A for testing instantaneous elements, two or three current channels may be connected in parallel to provide 60 or 90 A continuous, and up to 120 or 180 A for short durations. Note the SMRT43D is limited to 45 A per channel, up to 135 A in parallel operation for 1.5 s or 90 cycles.

Note: If an **F** or a **C** appears in the 5<sup>th</sup> digit of the style identification number (i.e., 30P1F0A0S1) the current returns are floating (isolated from each other and ground). Those units with a style number **G** or **E**, the current returns are common together internally and connected to earth ground.

To parallel the current channels of the unit, perform the following:

If using the sleeved multi-lead current test leads (part number 2001-396), all the black return leads are interconnected together inside the sleeve so they will all share the return current together. Connect each current channel to the relay under test (both red and black terminals to the load). Each Megger test lead is rated 32 A continuous. If using test leads other than those supplied by Megger, ensure that the wire has sufficient size to carry the test current.

! For the earth grounded common return (G or C) units, there is an internal common ground between the current channel return terminals. If using separate individual test leads, all the return leads will need to be common together at the load as shown in the following figure. By not connecting a return lead to all the current channels in use, part or all the return current will be forced through the internal ground. That means with a 3 channel SMRT46D unit, up to 180 A could be forced through the internal common ground and may cause damage to the internal common returns. Therefore, it is important that parallel connections must be made at the relay. See the following figure.

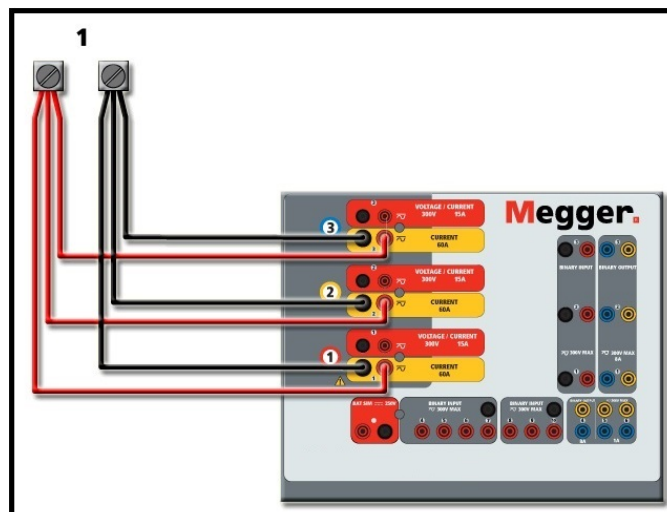

Figure 373 Parallel of All Three Current Outputs

### 3.1.1 Manual Test Screen - Single Phase Up To 180 A<sup>9</sup>

For ease of use and operator convenience, go to the Configuration screen and select the Operating Mode of **3 Voltages – 1 Current @ 180A**. When you return to the manual test screen there will be one current channel displayed, as shown in the following figure.

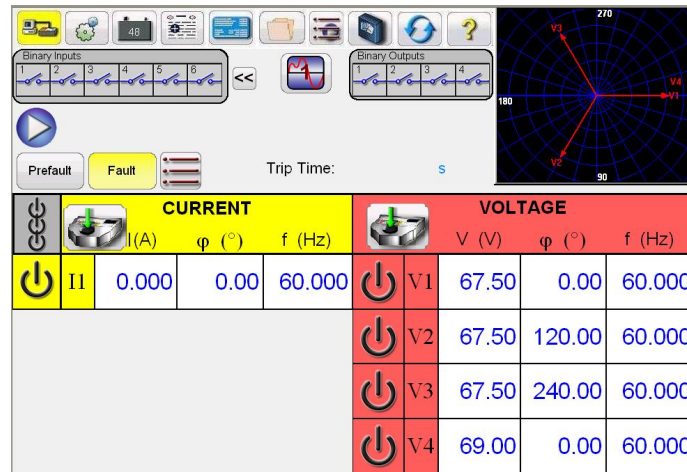

Figure 374 Manual Test Screen – Single Phase Operation

The STVI will automatically set all three currents in phase with each other and divide the current equally between the three current amplifiers. When setting an output, simply enter the value of the desired output current. For example, for an output of 75 A, enter 75, while each current amplifier will be providing 25 A. The current can also be phase shifted. Simply enter the desired phase angle and all three currents will be phase shifted together.

If two current channels are to be used in parallel, leave the unit in the default three phase configuration. Connect the two current outputs to the load as shown in the following figure.

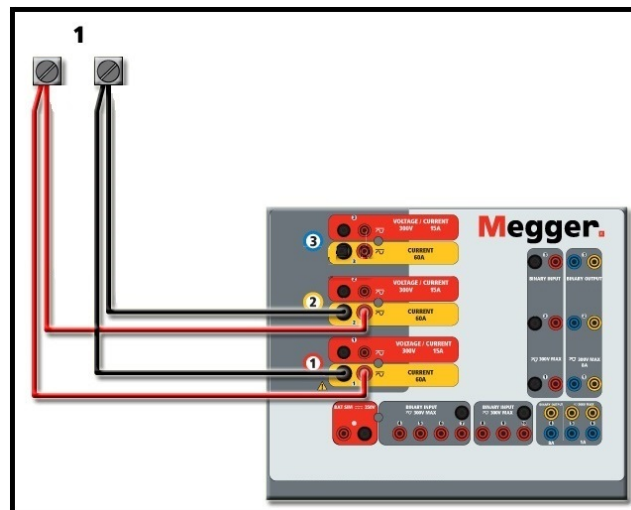



Figure 375 Two Currents in Parallel

Set each channel to one-half of the output requirement. Be sure and **reset current channel #2 to 0 degrees** so that it will be in-phase with current channel #1. With both current channels selected, turn output on by pressing or clicking on the ALL ON/OFF button. Always use the ALL ON/OFF button to turn both current channels on and off together. For manually ramping outputs, if using the PC version of RTMS the  $\uparrow \downarrow$  buttons will be displayed. If using the touch screen, the

Control Knob icon  will be displayed. Pressing either of these two will present the user with a window to select the desired level of increment for manually ramping the outputs, the desired channel(s) to be ramped, and what is to be adjusted (amplitude, phase angle or frequency).

### 3.2 Currents in Series Operation

Two current channels may be connected in series to double the available compliance voltage. High impedance electromechanical ground (earth) overcurrent relays have always been difficult to test at high multiples of tap due to the winding impedance and saturation characteristics. The peak voltage required can exceed the maximum output voltage of one SMRT43D/46D current output channel, depending on the required test current. By connecting two current outputs in series, the compliance voltage is doubled, providing higher test currents through the load. There are two methods to series currents together. For the **floating output** (F or C) models connect the two current amplifiers in a “push-push” configuration as shown in the following figure.

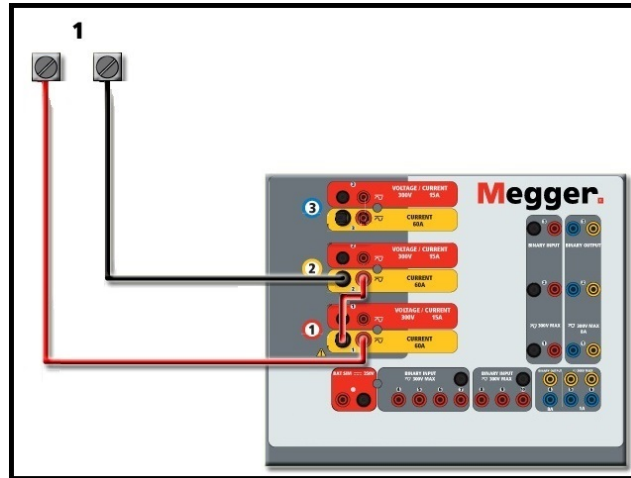



Figure 376 Series Two Currents with Floating Output Unit

The two current channels that are to be used in series set each to the same test current magnitude, and phase angle. Select both current channels and turn output on by pressing or clicking on the ALL ON/OFF button. Always use the ALL ON/OFF button to turn both current channels on and off together. For manually ramping outputs, if using the PC version of RTMS the  $\updownarrow$  buttons will be displayed. If using the touch screen, the Control Knob icon  will be displayed. Pressing either of these two will present the user with a window to select the desired level of increment for manually ramping the outputs, the desired channel(s) to be ramped, and what is to be adjusted (amplitude, phase angle or frequency).

To series the current channels of the **common grounded returns** (G or E) unit, perform the following:

Using the current channel test leads, connect the Red output terminals of the two current channels to the relay under test. Even though the two returns associated with the current channels are connected internally with the common returns, place a jumper as shown. This will ensure that the internal common leads will not be damaged.

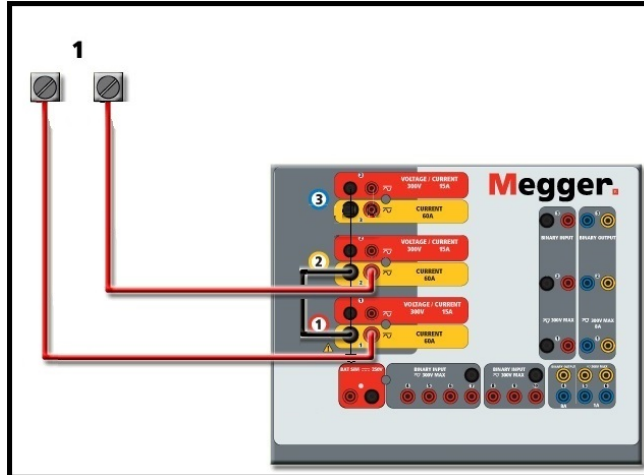



Figure 377 Series of Two Current Channels with Grounded Common Returns

- NOTE: One current channel should be set to 0 degrees and the other current channel should be set to a phase angle of 180 degrees so that the two compliance voltages add across the load. DO NOT attempt to series more than two currents together on a grounded common returns unit.

The two current channels that are to be used in series set each to the same test current magnitude. Initiate the two current channels simultaneously by pressing the ALL ON/OFF button. Always use the ALL ON/OFF button to turn both current channels on and off together. For manually ramping outputs, if using the PC version of RTMS the  $\uparrow\downarrow$  buttons will be displayed. If

using the touch screen, the Control Knob icon  will be displayed. Pressing either of these two will present the user with a window to select the desired level of increment for manually ramping the outputs, the desired channel(s) to be ramped, and what is to be adjusted (amplitude, phase angle or frequency).

#### 4.0 Voltage Sources

##### 4.1 Outputs Summed Together

Two voltage channels may be used to sum the voltage outputs to obtain higher than rated voltage provided the load is ungrounded. Connect the load between the voltage channel posts, set  $V_1$  Phase to  $0^\circ$  and set  $V_2$  Phase to  $180^\circ$ . The voltage outputs will add so the total voltage is the sum of the two voltage amplitudes,  $V_1$  and  $V_2$  as can be seen in the following figures.

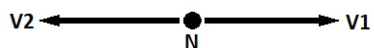

- Note: If an **F** or **C** appears in the 5<sup>th</sup> digit of the style identification number (i.e., 30P1**F**0A0S1) the voltage returns are **floating** (isolated from each other and ground). Those units with a style number **G** or **E** the voltage returns are **common together internally and connected to earth ground**.

For the **floating common** units, the user must connect the associated voltage channels black common returns together, when series operation is required (see the following figures). Remove external commons when testing is completed. DO NOT attempt to series more than two voltage channels together.

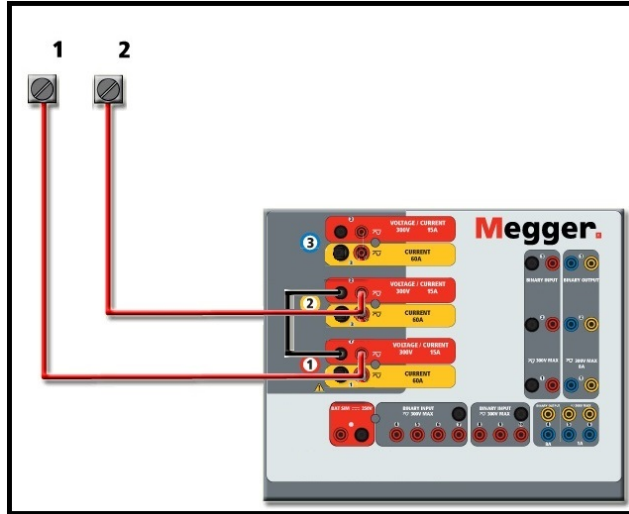

Figure 378 Series of Voltage Channels for **Floating Ungrounded Common Returns**

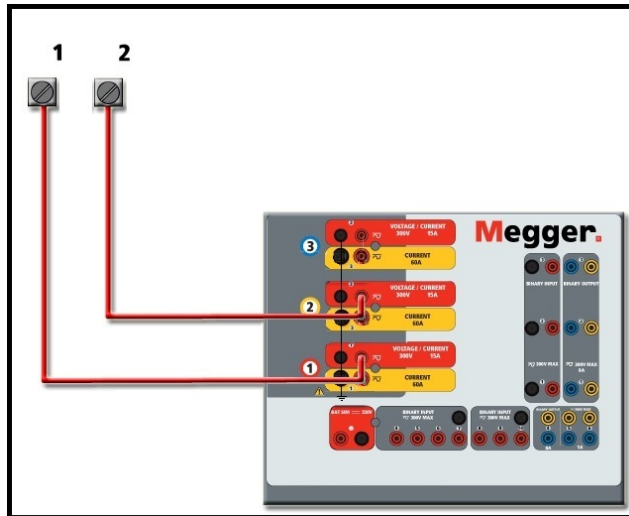

Figure 379 Series of Voltage Channels **with Grounded Common Returns**

#### 4.2 3Ø, 3-Wire, Open-Delta, and T-Connection

See section 3.4.2 in RTMS for detailed descriptions and use of the Open-Delta and T-Connection.

##### 4.2.1 Balanced Open Delta

The Open-Delta configuration is easy to use when a balanced three-phase source is required because the amplitude and phase relationship can be set directly. No calculations are necessary. When using the Open-Delta configuration, it is suggested to use voltage channel #1, designated  $V_1$ , and voltage channel #2, designated  $V_2$ , while the COMMON binding post is designated  $V_g$ . With this arrangement, the magnitude and phase angle of the potentials can be easily calculated and set. For the balanced three-phase condition  $V_{1g}$  and  $V_{2g}$  are equal in magnitude and separated by an angle of  $60^\circ$ . This is done by setting the  $V_1$  and  $V_2$  potentials equal in magnitude,

setting  $0^\circ$  on  $V_1$  and  $300^\circ$  ( $60^\circ$  leading assuming that the default phase rotation is set to  $360^\circ$  Lag) on  $V_2$ , see the following figure.

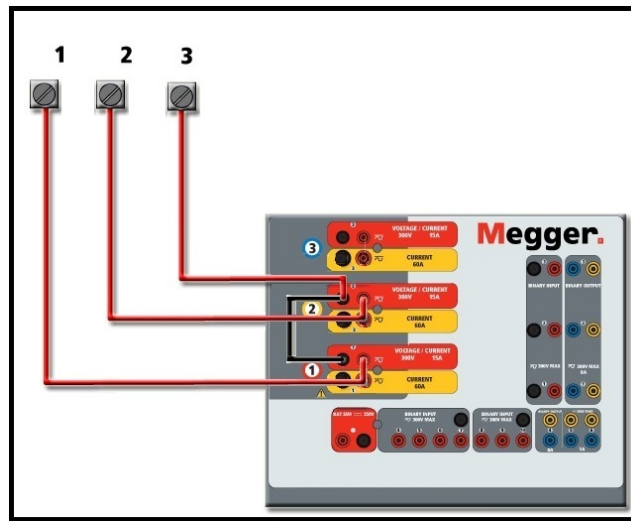

Figure 380 Three Phase Open Delta Connections

#### 4.2.2 T Connection

The second method of obtaining a three-phase, three-wire voltage source is the so-called T-Connection. The method, shown in the following figure, is easier to use when obtaining an unbalanced, phase - to -phase fault simulation since it eliminates calculations. To reduce confusion when using the T-Connection, the voltage output #1 is designated  $V_a$  and its phase angle set at  $0^\circ$ , voltage output #2 is designated  $V_b$  and its phase angle set for  $180^\circ$ , and voltage output #3 is designated  $V_c$  and its phase angle is set for  $270^\circ$ . Any combination of balanced three phase faults or unbalanced phase-to-phase fault conditions can be easily simulated. The following figure indicates these phase relationships.

**!** NOTE: This method should not be used for low fault voltages, or used on solid state relays that may be sensitive to this type of connection (i.e., 5 V or less, or for testing ABB or Westinghouse type SKD relays).

#### 4.3 $3\phi$ , 4-Wire, Y-Connection

A three-phase, four-wire potential system can be provided using three output modules. The vector relationships are referenced below. This Y-Connection has the advantage of being able to supply a higher line-to-line voltage ( $1.73 \times$  phase-to-neutral voltage). It is ideally suited for simulating phase-to-ground faults. Voltage channel #1 is designated as  $V_a$  with its phase relationship set for  $0^\circ$ . Voltage channel #2 is then designated as  $V_b$  and phase angle set for  $120^\circ$ . Finally, voltage channel #3 is designated  $V_c$  and phase angle set for  $240^\circ$  (for a 1-2-3 counterclockwise rotation).  $V_a$ ,  $V_b$  and  $V_c$  are connected to the voltage potential binding posts on the respective test sets.

**!** Note: If an **F** or **C** appears in the fifth digit of the style identification number (i.e., 30P1**F**0A0S1) the voltage returns are floating (isolated from each other and ground). Those units with a style number **G** or **E** the voltage returns are common together internally and connected to earth ground.

If using the sleeved multi-lead voltage test leads (part number 2001-395), all the black return leads are interconnected together inside the sleeve so they will all share the return together. Therefore, only one return lead is provided on the relay connection side of the sleeved leads (like the connections in the following figure).

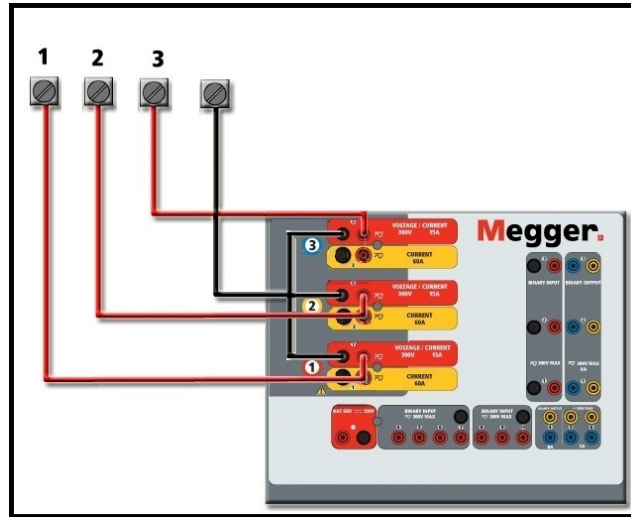

Figure 381 Three Phase Four Wire Test Connections

- For the earth grounded common return (G or E) units, there is an internal common ground between the voltage and current channel return terminals. Therefore, only one return lead is required for the voltage channels. If using separate individual test leads, for the floating common units the user must connect the associated voltage channels black common returns together as shown above.

# Megger<sup>®</sup>

## Addendum F



\* SMRT410 shown with DIGEN and "P" Plus options

## **Model SMRT410** **Megger Relay Tester**

## 1.0 Operation

The unit's design is a "modular" concept. All inputs and outputs are clearly marked and logically grouped so continual reference to the instruction manual should not be necessary once the operator is acquainted with the test system. The unit's Top Panel will appear different among units, since each unit may have up to three optional Voltage/Current Generator (VIGEN) Modules installed. The 'N' version consists of a system board with only power and communication ports. The 'P' version adds 8 additional binary inputs, 4 additional binary outputs and a battery simulator.

### 1.1 General Description

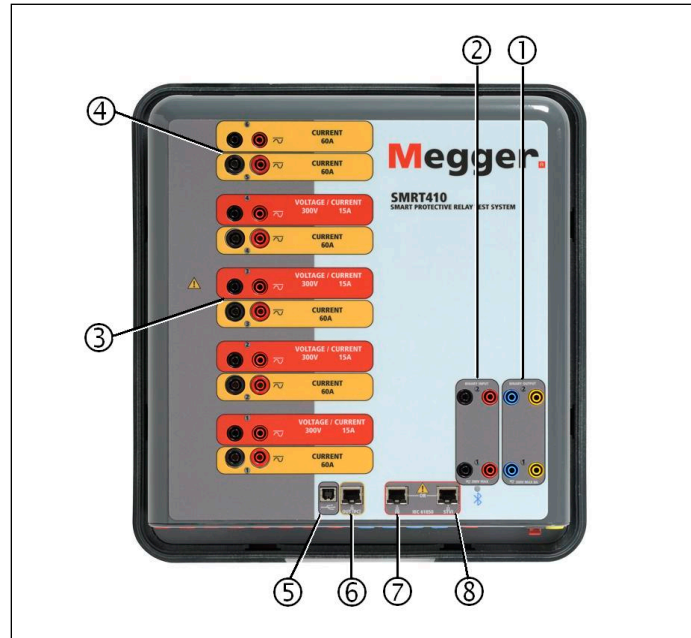

Figure 382 Top Panel SMRT410 (Pictured with Floating Returns and DIGEN Options)

#### 1.1.1 Top Panel

1. **Binary Outputs** – the first two VIGEN modules include Binary Inputs and Binary Outputs. Therefore, with a minimum 2 channel unit there are 2 Binary Outputs located on the top panel (numbered 1 and 2). More Binary Outputs are available with the P option see Front Panel section for more information. Each Binary Output can be configured as Normally Open or Normally Closed contacts providing logic to the device under test. The Top Panel Binary Outputs can switch up to 300 VAC or 250 VDC with 8 A continuous. The programmable wait duration is from 1 ms to 10,000 ms.
2. **Binary Inputs** – with a minimum of a 2 channel unit there are 2 Binary Inputs located on the top panel. Depending on the age of the unit, for typical test applications binary inputs 1 and 2 have a programmable voltage threshold from 2 to 150 V. Older units will have a fixed voltage threshold of 5 V AC/DC. For **GPS End-to-End synchronized relay testing Binary 1** may relate to a remote trigger pulse from a GPS satellite receiver for external initiation, or the input of an **IRIG-B** signal (see use of **Wait IRIG-B** input using the STVI Sequencer test). More Binary Inputs are available with the P option see Front Panel section for more information. The Binary Inputs will accept a voltage range of 5 to 300 VAC, or 5 to 250 VDC, or dry Normally Open/Normally Closed contacts.

3. **Voltage/Current Generator Module (or VIGEN)** –There are four available slots for the VIGEN Modules. The slots are numbered 1 to 4 from bottom to top, with the topmost VIGEN numbered 4. The four voltages and currents are noted by the red and yellow surrounding each output channel. Phases A, B, C and D Voltage Channels (V1, V2, V3 and V4) are denoted by the red color. Phases A, B, C and D Current Channels (I1, I2, I3 and I4) are denoted by the yellow color. When the voltage generators are converted to current generators, they will change on the STVI display as V1 = I5, V2 = I6, V3 = I7, and V4 = I8. For more details on the VIGEN output capabilities see section 1.4.
4. **Current/Current Generator Module (or DIGEN)** –There is one available slot for the DIGEN Module. Note that a 4 channel unit will not have the DIGEN slot. SMRT410 with the DIGEN option, the VIGEN Modules are numbered 1 to 4 from bottom to top, with the topmost VIGEN numbered 4. The DIGEN current channels are numbered 5 and 6. When the voltage generators are converted to current generators, they will change on the STVI display as V1 = I7, V2 = I8, V3 = I9, and V4 = I10. For more details on the VIGEN output capabilities see section 1.4.
5. **USB Interface** – the USB 2.0 Interface requires a Type B “downstream” connector and is primarily used as a communication and control port when used with a PC and Megger RTMS for automated relay testing. A USB cable is not provided with the test set or in the optional accessories. For computer control, an Ethernet cable is provided. However, should the user desire to use the USB port any standard USB A/B cable will work with the unit. May be used when isolation is required for a secure substation access between the SMRT and the IEC 61850 substation network.
6. **PC/OUT Ethernet Port** is a 10/100BaseTX port and is the primary PC connection port. This port supports MDI/MDI-X auto crossover configuration, which means both standard and “crossover” Ethernet cables may be used. This port provides the optimal method for downloading EMTP files, DFR streaming, and updating the unit’s firmware as required. The SMRT comes standard with a crossover cable. This port may also be used for connecting to the IEC 61850 substation bus for use in testing IEC 61850 devices. For multiple unit operation, the unit providing the OUT link provides the primary phase reference to all units “downstream.”
7. **IN - 61850 Ethernet Port** is a 10/100BaseTX port and is primarily used to interconnect multiple SMRT units together for synchronous multi-unit operation. It may also be used to provide access to the substation IEC 61850 network. Note that the IN and STVI ports share a common physical port and cannot be used at the same time. With the PC connected to the PC Port, the SMRT and the PC share the same Ethernet network connection, and thus will not have secure isolation from each other.
8. **STVI Ethernet Port** – this Ethernet port is a 10/100BaseTX PoE (Power over Ethernet) port and is the STVI connection port. Used for manual operation, and display outputs when under computer control.



### 1.1.2 Front Panel:

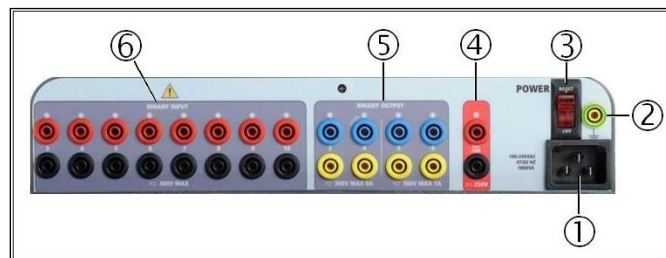

Figure 383 SMRT410 with P Option Front Panel

1. **Incoming Power/Line Cord** ① – the input line cord, ground terminal, are mounted on the front panel of the test set for both the N and P option units.

#### Input Line Cord



The test set is equipped with a line cord, which connects to the male connector on the front panel. Verify the input voltage before connecting the line cord to the power source.

2. **Earth Ground Jack** ② – use this terminal to connect chassis ground to earth ground.



A chassis ground (earth) point on the front panel is provided as an additional safety ground. Some units have a loss of ground sensing circuit as an optional feature. Should the safety ground be lost the software will issue a warning message that the ground has been lost and will not allow the unit to operate until the ground is reestablished.

3. **POWER ON/OFF Switch** ③ – used to switch unit on and off. The switch illuminates when power is on.
4. **Battery Simulator** ④ – the SMRT410 with the P option provides a variable DC output voltage from 5 to 250 V, at 100 W (4 A Max) providing logic voltage for solid-state relays. When powered ON, the LED above the output terminals illuminates. The SMRT410 with the N option does not include a battery simulator.
5. **Binary Outputs** ⑤ – the P option provides 4 additional Binary Outputs, numbered 3, 4, 5 and 6. Each Binary Output can be configured as Normally Open or Normally Closed contacts providing logic to the device under test. Binary Outputs 3 and 4 have an AC Rating of 400 V max., I<sub>max</sub>: 8 A, 2000 VA max. breaking capacity, and a DC Rating of 300 V max., I<sub>max</sub>: 8 A, 80 W, with a Response Time: < 10ms. Binary Outputs 5 and 6 are high speed and have an AC/DC Voltage Rating of 400 V peak, I<sub>max</sub>: 1 A, with a Response Time: < 1ms typical. The programmable wait duration is from 1 ms to 10,000 ms. An LED directly above the terminals indicates the status of the contact. ON indicates closed, and OFF indicates open. The SMRT410 with the N option does not include the additional Binary Outputs 3 through 6.
6. **Binary Inputs** ⑥ – the P option provides 8 additional (numbered 3 through 10), independent, galvanically isolated, Start/Stop or Monitor circuits to monitor operation of relay contacts or trip SCR. A continuity light is provided for each input gate. Upon sensing continuity, or voltage applied, the lamp will glow. In addition to serving as wet/dry contacts the Binary Inputs may be programmed to trigger binary output sequence(s). Binary Inputs can also be programmed using Boolean logic for more complex power system simulations. The Binary Inputs will accept a voltage range of 5 to 300 VAC or 5 to 250 VDC, or dry Normally Open/Normally Closed contacts. The SMRT410 with the N option does not include the additional Binary Inputs 3 through 10.

## 1.2 Input Power

The input voltage rating may be from 100 to 240 VAC,  $\pm 10\%$ , 50/60 Hz. Input current required varies with the number of output modules in use, load, and input voltage value. With three

VIGENS, the maximum input power is 1800 VA. The input is protected by a power ON/OFF switch/circuit breaker.

### 1.2.1. Input Power Cord

Depending on the country, the power cord can come with a NEMA 5-15 male connector, a CEE 7/7 Schuko two prong connector, with International Color Coded pig-tail wires (light blue, brown and green with yellow stripe) with the insulation jacket stripped ready for installation of the appropriate male connector, or with UK power cord.

Model SMRT410 **XXXXXXA** comes with a North American power cord (part number 620000).

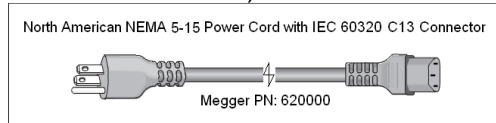

Model SMRT410 **XXXXXXE** comes with a Continental Europe power cord (part number 50425).

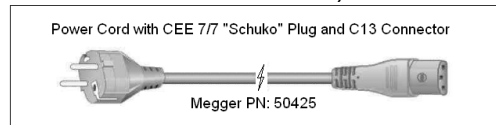

Model SMRT410 **XXXXXXI** comes with an International Color Code power cord. The cord, part number 15065, is ready for wiring to the appropriate plug (depending on country). The following colors apply, Brown = Line, Blue = Neutral and Green/Yellow = Ground.

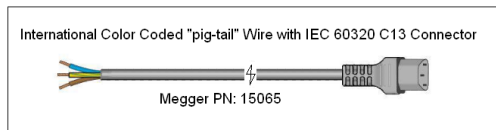

Model SMRT410 **XXXXXXU** comes with a UK power cord (part number 90002-989).

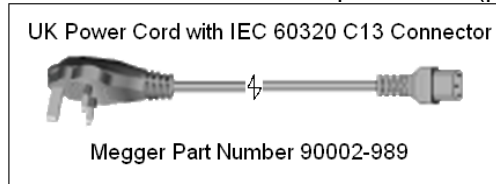

## 1.3 Voltage - Current Generator (VIGEN) and Double-Current (DIGEN) Modules

Voltages and Currents are noted by the red and yellow surrounding each output channel. Phases 1, 2, 3 and 4 voltage channels are denoted by the red color. Phases 1, 2, 3 and 4 current channels are denoted by the yellow color. The optional Double Current module includes two current channels phases 5 and 6 and are also surrounded by yellow. All outputs are independent from sudden changes in mains voltage and frequency and are regulated so changes in load impedance do not affect the output. All amplifier outputs are isolated or floating. The SMRT units can be ordered with the amplifier common returns tied to chassis ground as an option.

### 1.3.1. Convertible Voltage/Current Amplifier

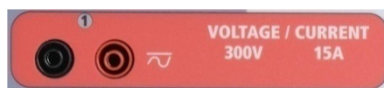

The SMRT PowerV™ voltage amplifier provides a flat power curve from 30 to 150 V in the 150 V range to permit testing of high current applications such as panel testing. The following outputs are provided.

Voltage Range	Power/Current (Max)
30.00 V	150 VA @ 5.0 A
150.00 V	150 VA Constant Output Power from 30 to 150 V
300.00 V	150 VA @ 0.5 A

Voltage Amplifier in Current Mode :

The voltage amplifier is convertible to a current source with the following output capability. Output power ratings are specified in RMS values and peak power ratings.

Output Current	Power	Max V	Duty Cycle
5 A	150 VA (212 peak)	30.0 V RMS	Continuous
15 A	120 VA	8.0 V RMS	1.5 s or 90 cycles

With a 4 channel SMRT unit, convertible channels in conjunction with the four main current channels, provides 8 currents. When the voltage generators are converted to current generators, they will change on the STVI display as current phases 5, 6, 7, and 8. If the optional Double-Current (DIGEN) module is installed, the convertible channels will be labeled current phases 7, 8, 9, and 10.

 The voltage amplifier output is protected from short circuits and thermally protected against prolonged overloads. In case of a short circuit or a thermal overload, the amplifier will automatically turn off, and if the STVI is connected a message to the user will be displayed indicating which condition exists.

### 1.3.2. Current Amplifier



The SMRT current amplifier delivers maximum compliance voltage to the load constantly during the test, and range changing is done automatically, on-the-fly, under load. This ensures better test results, saves time by not having to turn the outputs off to change output taps or ranges, and unlike single range current amplifiers ensures a higher compliance voltage at lower test currents. Constant power output in many cases eliminates the need to parallel or series current channels together to test high burden relays. The following are typical output current and associated available compliance voltage values. The per channel output current and power ratings are specified in AC RMS values and peak power ratings. Specified duty cycles are based upon typical room temperature.

Output Current	Power	Max V/Duty Cycle
1 A	15 VA	15.0 V RMS Continuous
4 A	200 VA (282 peak)	50.0 V RMS Continuous
15 A	200 VA (282 peak)	13.4 V RMS Continuous
32 A	200 VA (282 peak)	6.25 V RMS Continuous
60 A	319 VA (424 peak)	5.00 V RMS 1.5 s or 90 cycles
DC 200 W		

 The current amplifier output is protected from open circuits and thermally protected against prolonged overloads. In case of an open circuit or a thermal overload, the amplifier will automatically turn off, and if the STVI is connected a message to the user will be displayed indicating which condition exists.

## 1.4 Binary Inputs and Outputs

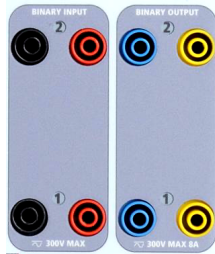

Figure 384 Binary Inputs and Outputs 1 and 2

Binary Inputs and Outputs are clearly marked and logically grouped. The unit's Top Panel will appear different among units, which means Binary Input/Output 1 will always be occupied while Binary Input/Output 2 may, nor may not, depending on the configuration. The 'N' version consists of a system board with only power and communication ports. The 'P' version adds 8 additional binary inputs, 4 additional binary outputs and a battery simulator. The Binary Inputs are used to monitor relay trip contacts for performing pickup and dropout tests as well as for performing timing functions. The Binary Outputs are used to simulate normally open/normally closed contacts for testing breaker failure schemes, or similar power system operations. In addition, they may also be used to switches AC/DC voltages and currents.



Figure 385 "P" Option Binary Inputs 3 to 10 and Binary Outputs 3 to 6

### 1.4.1 Binary Inputs

The binary inputs are specifically designed to measure high speed operation of electro-mechanical, solid-state, and microprocessor-based protection relays. All binary Inputs default to Monitor Mode, Contact change of state, latched OFF.

If using RTMS to change a binary input from Contact change of state to Voltage Applied/Removed click on or touch the Input Type window and a sine wave will appear where the Contact icon was indicating. The input is now set for voltage sensing.

To change the binary input from Monitor mode to Timer Mode, click on or touch the Use as Monitor button and the display window will change to show Use as Trip, Latched, meaning the binary input is now set to stop the timer upon sensing the first contact closure (if the Input Type is set for contact) or upon sensing voltage if the Input Type is set to Voltage Sensing.

#### 1.4.1.1 Start, Stop, and Monitor Gates

In the SMRT410 there are up to ten identical, independent, programmable gate circuits that permit simple selection of the desired mode for timing or contact monitoring operation.

To monitor operation of the contacts or trip SCR in the device under test, a light is provided for each gate. The gate circuit is isolated for voltage-sensing and can monitor solid-state logic signals. Each light will illuminate once contacts close or voltage is applied to the gate.

#### 1.4.1.1.1 Dry Contacts Open

Timer stops or a continuity indicator goes out at the opening of normally closed contacts, or when conduction through a semiconductor device, such as a triac or a transistor, is interrupted.

#### 1.4.1.1.2 Dry Contacts Close

Timer stops or a continuity indicator glows at the closing of the normally open contacts, or upon conduction through a semiconductor device such as a triac or a transistor.

#### 1.4.1.1.3 Application or Removal of AC or DC voltage

This will either start the Timer or stop the Timer. The continuity indicator will glow (application) or darkens (removal) upon the application or removal of either an AC or DC voltage. To serve a wide range of test applications, the binary inputs have different voltage thresholds. Depending on the age of the unit, for typical test applications, binary inputs 1 and 2 have programmable voltage thresholds from 2 to 150 V. Older units have a fixed voltage threshold of 5 V AC/DC. On the "P" model there are an additional 8 binary inputs. To monitor TTL signals binary inputs 3 through 6 have a fixed threshold of 3 V. Binary inputs 7 and 8 have fixed thresholds of 5 V, and binary inputs 9 and 10 have fixed thresholds of 30 V (for "noisy" test environments). A higher threshold voltage helps to eliminate false triggers due to a noisy source. Lower thresholds allow the starting and stopping of timer from TTL voltage signals. The allowable voltage applied is 5 to 300 VAC or 5 to 300 VDC, current limiting resistors provide protection.

1.4.1.1.4 The Timer can be started when turning on any selected generators.

1.4.1.1.5 The Timer can be started simultaneously with a change in Frequency, Phase Angle, or Amplitude. Also, it can be started simultaneously with a Voltage or Current waveform step.

### 1.4.2 Binary Outputs

Binary Outputs 1 and 2 are located on the top panel, rated for 300 V at 8 A. The SMRT410 "P" system board option provides four additional Binary Outputs numbered 3, 4, 5 and 6. Each Binary Output can be configured as normally open or normally closed contacts providing logic to the device under test. Binary Outputs 3 and 4 have a rating of 300 V AC/DC, 8 A and a maximum of 2000 VA breaking capacity (80 W DC), with a response time of less than 10 ms. Binary Outputs 5 and 6 are high speed and have an AC/DC voltage rating of 400 V peak, 1 A and a response time typically less than 1ms.

The contacts may be programmed to open or close, thus simulating circuit breaker operation. The programmable wait duration is from 1 ms to 10,000 ms. A fused test lead (fused at 500 mA) is available as an optional accessory to help protect from blowing the internal fuse of binary outputs 5 & 6. The test lead is blue in color so that the user knows it applies to the blue binary outputs. The barrel holder of the test lead is CE marked with a 1000 V, CAT III rating, and marked FUSED 500 mA/1000 V/50 kA.

## 1.5 Battery Simulator



The SMRT410 "P" model includes the battery simulator and provides a variable DC output from 5 to 250 VDC rated at 100 W, 4 A max. User may select from normal setting values of 24, 48, 125, or 250 VDC, or enter the desired output voltage in the window provided, see the STVI Configuration Screen. The primary application is to provide DC logic voltage to solid-state and microprocessor relays.

Figure 386 Battery Simulator (BAT SIM)



**CAUTION:**

**NOTE:** DC voltage is ON and available when the output is turned on using the LCD touch panel or via software command. Do not plug or insert any test lead into the BATTERY SIMULATOR binding posts without first connecting the test leads to the load!

2.0 **SETUP**

2.1 **Unpack System**

Unpack the unit and check for evidence of any shipping damage. If there is any visual damage, immediately notify the freight carrier to make a damage claim and notify Megger of the damage.



**CAUTION:**

**Potentially lethal voltages may be present on the output terminals. It is highly recommended the operator read the user manual thoroughly and understand the test set operation prior to turning power on.**

2.1.1 **Initial Start Up**

3. With the Ethernet cable supplied with the unit connect the **STVI** Ethernet Port on the SMRT unit to the Ethernet port on the top of the Smart Touch View Interface (STVI). If using RTMS on a PC, connect the **PC/OUT** Ethernet Port on the SMRT unit to the PC Ethernet port.
4. Before connecting power to the unit, make sure the POWER ON/OFF Switch is in the OFF position (0). Plug the unit line cord into an appropriate power source and turn the POWER ON/OFF Switch to ON (I). As the SMRT unit goes through its power up sequence, in about a minute the STVI power up screen will appear, then the manual start up screen will appear.

2.2 **Communication Ports**

There are several communication ports. These ports are: one USB, three Ethernet, and an optional Bluetooth wireless port. To connect with Bluetooth, the activation code is 0000 (that is four zeros).

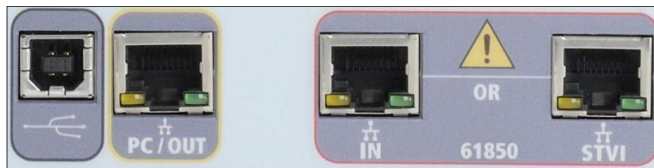

### 2.2.1 USB 2.0 Interface

USB 2.0 Interface requires a Type B “downstream” connector and is primarily used as a communication and control port when used with a PC and Megger RTMS or RTMS on the STVI for automated relay testing.

### 2.2.2 PC/OUT Ethernet Port

PC/OUT Ethernet Port is a 10/100BaseTX port and is the primary PC connection port automated relay testing. This port supports MDI/MDI-X auto crossover configuration, which means both standard and “crossover” Ethernet cables may be used. The SMRT comes standard with a crossover cable.

In addition, this port may be used to download large blocks of data into the unit. It is used to download digital samples for DFR playback and download software/firmware updates. Each output channel can store up to 256,000 samples of Digital Data, such as in Digital Fault Recordings for DFR playback, and with up to six channels that equals over 1.5 million samples. The Ethernet port on the SMRT410 should download the data in 1 s or less. In addition to high-speed downloads of DFR data, the port is also used to talk to the SMRT410 unit via a Network.

This port may also be used to interconnect multiple SMRT units together for synchronous multi-phase operation.

#### 2.2.2.1 Setting SMRT IP Address for Operation with a PC

With the Ethernet cable supplied with the unit, connect the **PC/OUT** Ethernet Port on the SMRT unit to the PC Ethernet port. Turn the test set on. As the SMRT unit goes through its power up sequence, in less than a minute the STVI power up screen will appear. If using the PC version of RTMS it will auto-detect the SMRT unit connected to the PC. Once it auto-detects the unit, and determines the configuration of the SMRT unit connected, the Manual screen will appear. The unit might not auto detect due to firewall settings. In this case the firewall can be turned off or you can enter the IP address directly using the PowerDB instrument configuration screen by clicking

on the Instrument Setup icon on the PowerDB tool bar . From the Instrument Configuration Screen, shown in the following figure, click off the check mark in the Auto Discover Unit box.

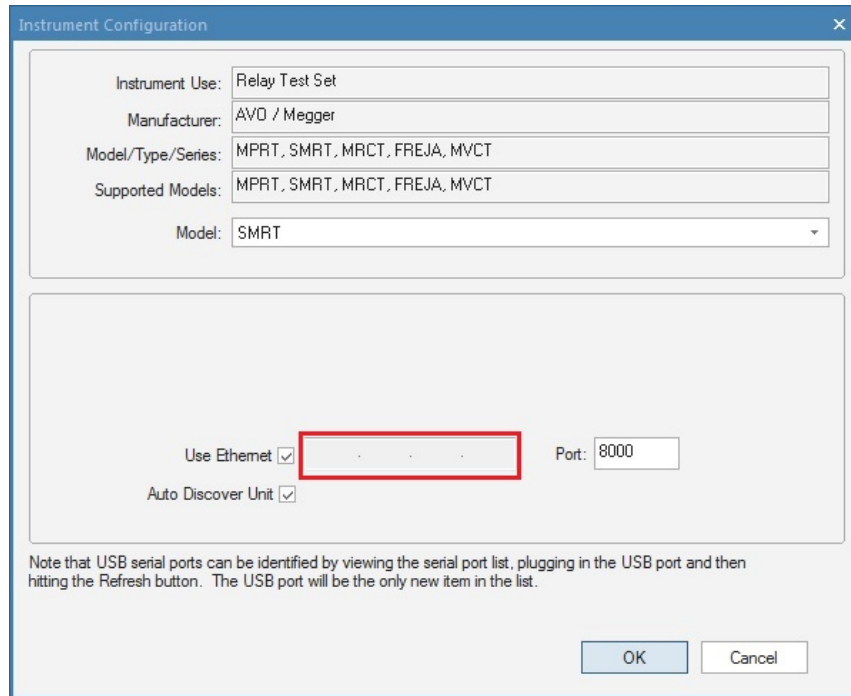

Figure 387 PowerDB Instrument Setup Screen

With the Auto Discover Unit box checked RTMS should find the unit. If not, the IP address can be entered in the box highlighted in the figure above. Also note that the IP address is also printed on the unit nameplate sticker. If the unit is on a network with a DHCP server, the user must use the Auto Discovery mode.

### 2.2.3 STVI Ethernet Port

**STVI** Ethernet Port is a 10/100BaseTX PoE (Power over Ethernet) port, which is the STVI connection port. This port provides power to the STVI using POE (Power Over Ethernet), and manual control of the SMRT unit with the STVI.

#### 2.2.3.1 Setting SMRT IP Address for Operation with STVI

With the Ethernet cable supplied with the unit, connect the **STVI** Ethernet Port on the SMRT top panel to the Ethernet port on the top of the Smart Touch View Interface (STVI). As the SMRT unit goes through its power up sequence, in less than a minute the STVI power up screen will appear. The STVI will auto-detect the SMRT410 (does not require the user to input an IP address). Once it auto-detects the unit, and determines the configuration of the SMRT unit connected; the Manual screen will appear.

### 2.2.4 IN - IEC61850 Ethernet Port

IN Ethernet Port is a 10/100BaseTX port and is used when interconnecting multiple SMRT units together. It also provides access to the substation IEC 61850 network (when enabled). The SMRT410 with the IEC 61850 option provides selectable priority, VLAN-ID, and meets the IEC 61850-5 standard Type 1A, Class P 2/3, for high speed trip and reclose simulations.

### 2.2.4.1 Setting SMRT IP Address for Networks or IEC 61850 Operations



The SMRT410 may be controlled over a network. This provides remote control of the SMRT410 over any distance allowing one PC to control at least two units simultaneously, such as in end to end testing.



Connecting the SMRT410 to a Local Area Network or a Wide Area Network could permit unauthorized operation of the unit.

Through the IN Ethernet port, the SMRT410 integrates into a network just like a PC or server. Using this feature requires the user to setup the IP configuration of the SMRT410 for their LAN. Note that the SMRT410, when turned on will automatically search for and acquire a network address if connected to a network. If it fails to automatically acquire an address check to make sure you are properly connected using a standard Ethernet cable. **Do not** use the cross over Ethernet cable supplied with the test set (a cross over cable is designed for use from your PC to the test set, not to a network). If the unit still fails to acquire an address, then there may be other issues. This will require assistance from your company's information management department.

For IEC 61850 testing connect the IEC61850 IN port to the substation bus or to the relay under test to receive and send GOOSE messages. When used with the Megger GOOSE Configurator in RTMS, the SMRT410 can provide high speed testing of IEC 61850 relays and substations by subscribing to GOOSE messages and mapping to the binary inputs. In addition, it can simulate system conditions such as circuit breaker operation by publishing GOOSE messages mapped to the SMRT410 binary outputs. With the PC connected to the OUT port, and running Megger GOOSE Configurator (MGC), the operator can "sniff" the substation network. However, if a secure port is desired, where the operator cannot accidentally trip off the substation or inflect a PC virus into the substation LAN, connect the PC to the SMRT USB port and sniff the network through the IEC61850 IN port.

## 3.0 Current Sources

### 3.1 Parallel Operation

Each SMRT current amplifier can provide 32 A continuous, and up to 60 A for 1.5 s for testing instantaneous trip elements. When more than 32 A single phase is required for long durations, or 60 A for testing instantaneous elements, three or more current channels may be connected in parallel to provide 90 up 180 A continuous, and from 180 up to 360 A for short durations.



Note: If an **F** appears in the 5<sup>th</sup> digit of the style identification number (i.e., 40P1**F**0A0S1) the current returns are floating (isolated from each other and ground). Those units with a style number **G**, the current returns are common together internally and connected to earth ground.

To parallel the current channels of the unit, perform the following:

If using the sleeved multi-lead current test leads (part number 2001-396), all the black return leads are interconnected together inside the sleeve so they will all share the return current together. Connect each current channel to the relay under test (both red and black terminals to the load). Each Megger test lead is rated 32 A continuous. If using test leads other than those supplied by Megger, ensure that the wire has sufficient size to carry the test current.



For the earth grounded common return (G) units, there is an internal common ground between the current channel return terminals. If using separate individual test leads, all the return leads will need to be common together at the load as shown in the following figure. By not

connecting a return lead to all the current channels in use, part or all the return current will be forced through the internal ground. That means with 4 channels in parallel up to 240 A could be forced through the internal common ground and will cause damage to the internal common returns. Therefore, it is important that parallel connections must be made at the relay. See the following figure.

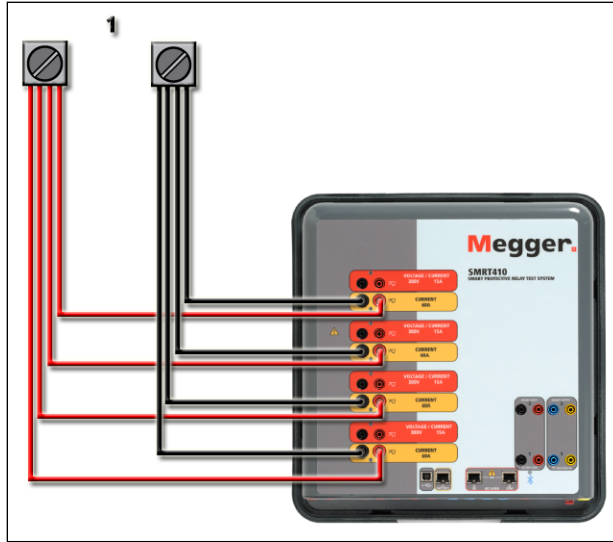

Figure 388 Parallel of Four Current Outputs

### 3.1.1 Manual Test Screen - Single Phase Up To 240 A

For ease of use and operator convenience, go to the Configuration screen and select the Operating Mode of **4 Voltages – 1 Current @ 240A**. When you return to the manual test screen there will be one current channel displayed, as shown in the following figure.

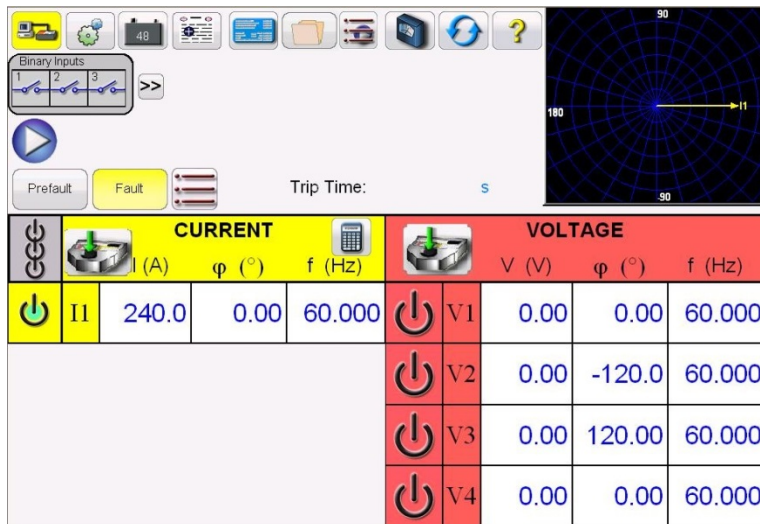

Figure 389 Manual Test Screen – 4 Channel SMRT410 Single Phase Operation

The STVI will automatically set all four currents in phase with each other and divide the current equally between the four current amplifiers. When setting an output, simply enter the value of the

desired output current. For example, for an output of 100 A, enter 100, while each current amplifier will be providing 25 A. The current can also be phase shifted. Simply enter the desired phase angle and all four currents will be phase shifted together.

If two current channels are to be used in parallel, leave the unit in the default four phase configuration. Connect the two current outputs to the load as shown in the following figure.

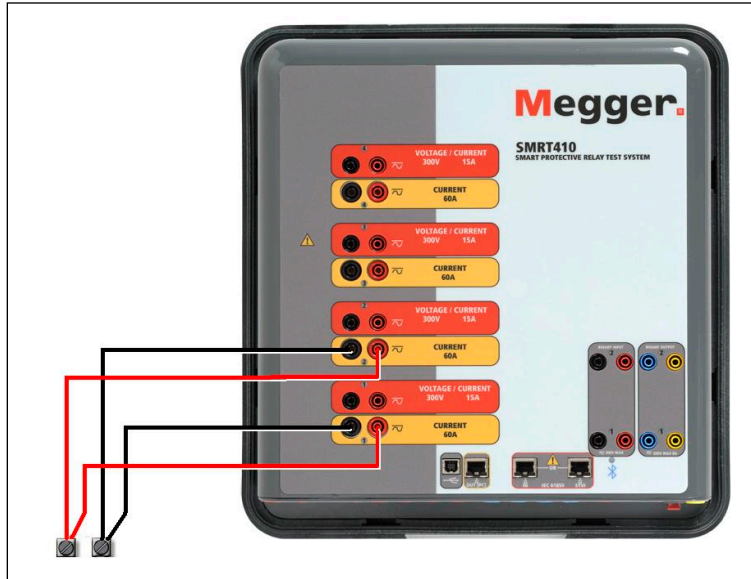



Figure 390 Two Currents in Parallel

Set each channel to one-half of the output requirement. Be sure and reset current channel #2 to 0 degrees so that it will be in-phase with current channel #1. With both current channels selected, turn output on by pressing or clicking on the ALL ON/OFF button. Always use the ALL ON/OFF button to turn both current channels on and off together. For manually ramping outputs, if using the PC version of RTMS the  $\uparrow\downarrow$  buttons will be displayed. If using an STVI controller the Control

Knob icon  will be displayed. Pressing either of these two will present the user with a window to select the desired level of increment for manually ramping the outputs, the desired channel(s) to be ramped, and what is to be adjusted (amplitude, phase angle or frequency).

### 3.2 Currents in Series Operation

Two current channels may be connected in series to double the available compliance voltage. High impedance electromechanical ground (earth) overcurrent relays have always been difficult to assess at high multiples of tap due to the winding impedance and saturation characteristics. The peak voltage required can exceed the maximum output voltage of one SMRT410 current output channel, depending on the required test current. By connecting two current outputs in series, the compliance voltage is doubled, providing higher test currents through the load. There are two methods to series currents together. For the floating output (F) models connect the two current amplifiers in a “push-push” configuration as shown in the following figure.

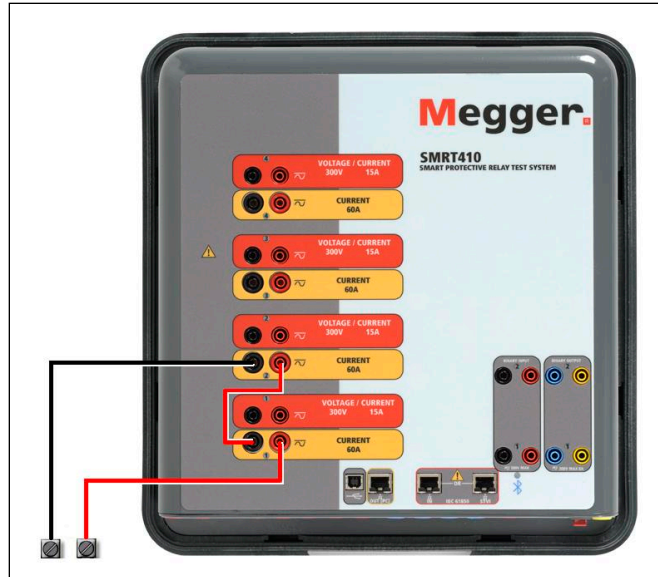



Figure 391 Series Two Currents with Floating Output Unit

The two current channels that are to be used in series set each to the same test current magnitude, and phase angle. Select both current channels and turn output on by pressing or clicking on the ALL ON/OFF button. Always use the ALL ON/OFF button to turn both current channels on and off together. For manually ramping outputs, if using the PC version of RTMS the

↑↓ buttons will be displayed. If using an STVI controller the Control Knob icon  will be displayed. Pressing either of these two will present the user with a window to select the desired level of increment for manually ramping the outputs, the desired channel(s) to be ramped, and what is to be adjusted (amplitude, phase angle or frequency).

To series the current channels of the common grounded returns (G) unit, perform the following:

Using the current channel test leads, connect the Red output terminals of the two current channels to the relay under test. Even though the two returns associated with the current channels are connected internally with the common returns, place a jumper as shown. This will ensure that the internal common leads will not be damaged.

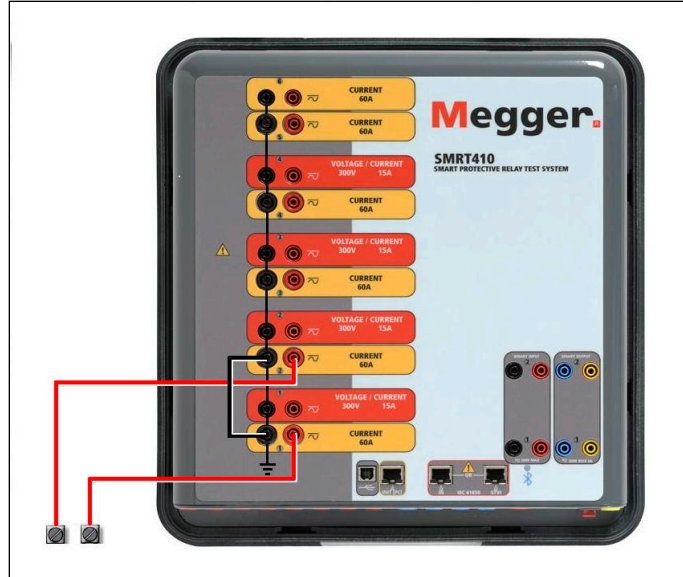



Figure 392 Series of Two Current Channels with Grounded Common Returns

**!** NOTE: One current channel should be set to 0 degrees and the other current channel should be set to a phase angle of 180 degrees so that the two compliance voltages add across the load. DO NOT attempt to series more than two currents together on a grounded common returns unit.

The two current channels that are to be used in series set each to the same test current magnitude. Initiate the two current channels simultaneously by pressing the ALL ON/OFF button. Always use the ALL ON/OFF button to turn both current channels on and off together. For manually ramping outputs, if using the PC version of RTMS the  $\uparrow\downarrow$  buttons will be displayed. If using an STVI controller the Control Knob icon  will be displayed. Pressing either of these two will present the user with a window to select the desired level of increment for manually ramping the outputs, the desired channel(s) to be ramped, and what is to be adjusted (amplitude, phase angle or frequency).

#### 4.0 Voltage Sources

##### 4.1 Outputs Summed Together

Two voltage channels may be used to sum the voltage outputs to obtain higher than rated voltage provided the load is ungrounded. Connect the load between the voltage channel posts, set  $V_1$  Phase to  $0^\circ$  and set  $V_2$  Phase to  $180^\circ$ . The voltage outputs will add so the total voltage is the sum of the two voltage amplitudes,  $V_1$  and  $V_2$  as can be seen in the picture below.

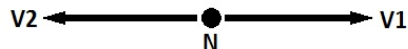

**!** Note: If an **F** appears in the 5<sup>th</sup> digit of the style identification number (i.e., 40P1**F**0A0S1) the voltage returns are floating (isolated from each other and ground). Those units with a style number **G** the voltage returns are common together internally and connected to earth ground.

For the floating common units, the user must connect the associated voltage channels black common returns together, when series operation is required (see the following figures). Remove external commons when testing is completed.



DO NOT attempt to series more than two voltage channels together. The test leads are rated for 600 V maximum.

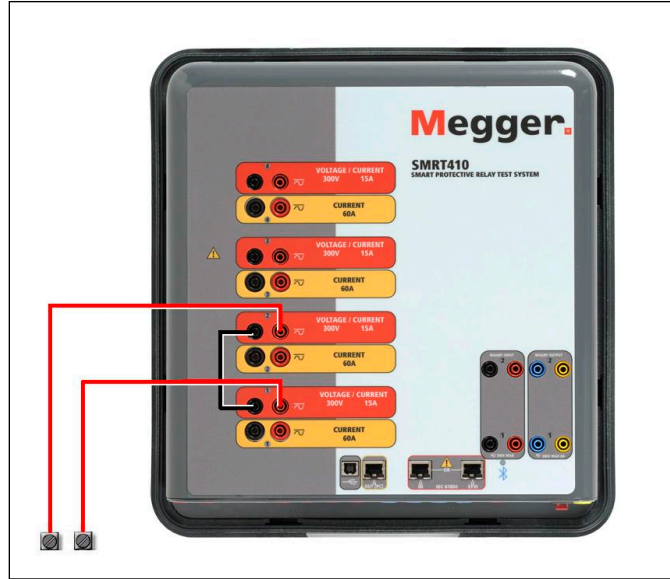

Figure 393 Series of Voltage Channels for Floating Ungrounded Common Returns

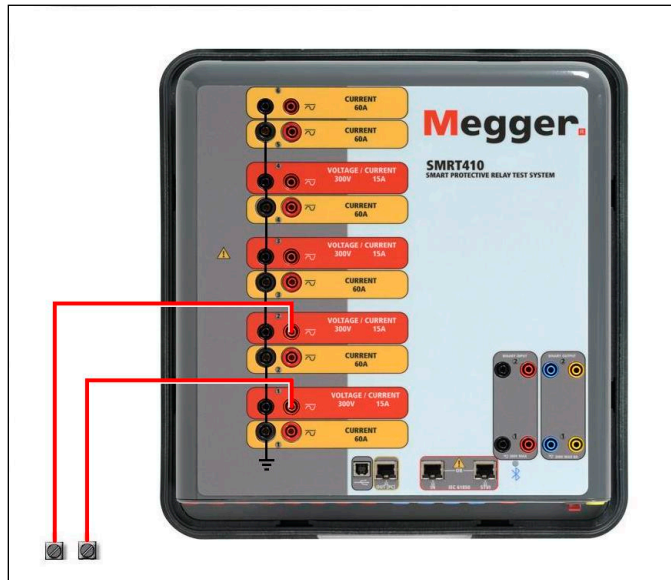

Figure 394 Series of Voltage Channels with Grounded Common Returns

## 4.2 3Ø, 3-Wire, Open-Delta, and T-Connection

See section 3.4.2 in RTMS for detailed descriptions and use of the Open-Delta and T-Connection.

### 4.2.1 Balanced Open Delta

The Open-Delta configuration is easy to use when a balanced three-phase source is required because the amplitude and phase relationship can be set directly. No calculations are necessary. When using the Open-Delta configuration, it is suggested to use voltage channel #1, designated  $V_1$ , and voltage channel #2, designated  $V_2$ , while the COMMON binding post is designated  $V_g$ . With this arrangement, the magnitude and phase angle of the potentials can be easily calculated and set. For the balanced three-phase condition  $V_{1g}$  and  $V_{2g}$  are equal in magnitude and separated by an angle of  $60^\circ$ . This is done by setting the  $V_1$  and  $V_2$  potentials equal in magnitude, setting  $0^\circ$  on  $V_1$  and  $300^\circ$  ( $60^\circ$  leading assuming that the default phase rotation is set to  $360^\circ$  Lag) on  $V_2$ , see the following figure.

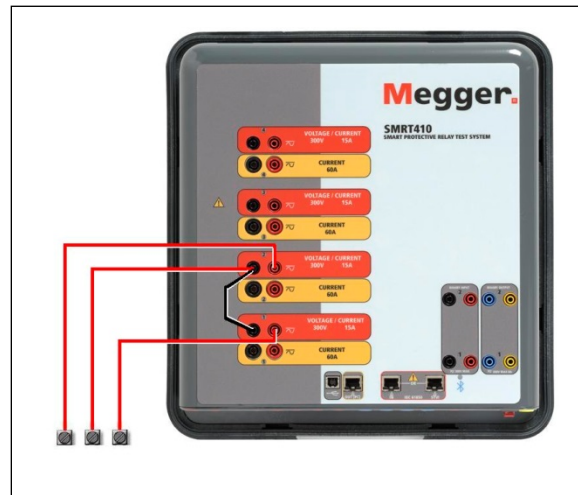

Figure 395 Three Phase Open Delta Connections

### 4.2.2 T Connection

The second method of obtaining a three-phase, three-wire voltage source is the so-called T-Connection. The method, shown in the following figure, is easier to use when obtaining an unbalanced, phase - to -phase fault simulation since it eliminates calculations. To reduce confusion when using the T-Connection, the voltage output #1 is designated  $V_a$  and its phase angle set at  $0^\circ$ , voltage output #2 is designated  $V_b$  and its phase angle set for  $180^\circ$ , and voltage output #3 is designated  $V_c$  and its phase angle is set for  $270^\circ$ . Any combination of balanced three phase faults or unbalanced phase-to-phase fault conditions can be easily simulated.

**!** NOTE: This method should not be used for low fault voltages, or used on solid state relays that may be sensitive to this type of connection (i.e., 5 V or less, or for testing ABB or Westinghouse type SKD relays).

### 4.3 3Ø, 4-Wire, Y-Connection

A three-phase, four-wire potential system can be provided using three output modules. The vector relationships are referenced below. This Y-Connection has the advantage of being able to supply a higher line-to-line voltage (1.73 x phase-to-neutral voltage). It is ideally suited for simulating phase-to-ground faults. Voltage channel #1 is designated as  $V_a$  with its phase relationship set for  $0^\circ$ . Voltage channel #2 is then designated as  $V_b$  and phase angle set for  $120^\circ$ . Finally, voltage channel #3 is designated  $V_c$  and phase angle set for  $240^\circ$  (for a 1-2-3 counterclockwise rotation).  $V_a$ ,  $V_b$  and  $V_c$  are connected to the voltage potential binding posts on the respective test sets.

**!** Note: If an **F** appears in the fifth digit of the style identification number (i.e., 40P1**F**0A0S1) the voltage returns are floating (isolated from each other and ground). Those units with a style number of **G** voltage returns are common together internally and connected to earth ground.

If using the sleeved multi-lead voltage test leads (part number 2001-395), all the black return leads are interconnected together inside the sleeve so they will all share the return together. Therefore, only one return lead is provided on the relay connection side of the sleeved leads (like the connections in the following figure).

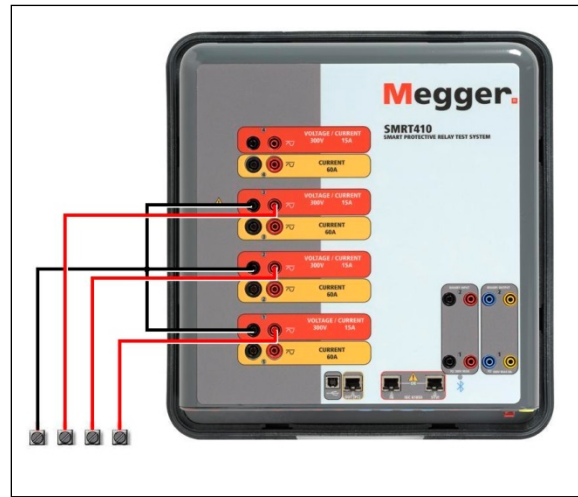

Figure 396 Three Phase Four Wire Test Connections

**!** For the earth grounded common return (G) units, there is an internal common ground between the voltage and current channel return terminals. Therefore, only one return lead is required for the voltage channels. If using separate individual test leads, for the floating common units the user must connect the associated voltage channels black common returns together as shown above.

# Megger<sup>®</sup>

## Addendum G



### **Model SMRT410D** **Multi-Phase Relay Test System**

## 1.0 Operation

The unit's design is a "modular" concept. All inputs and outputs are clearly marked and logically grouped so continual reference to the instruction manual should not be necessary once the operator is acquainted with the test system. The unit's Top Panel will appear different among units, since each unit may have up to four optional Voltage/Current Generator (VIGEN) Modules, or optional Transducer input terminals installed.

### 1.1 General Description

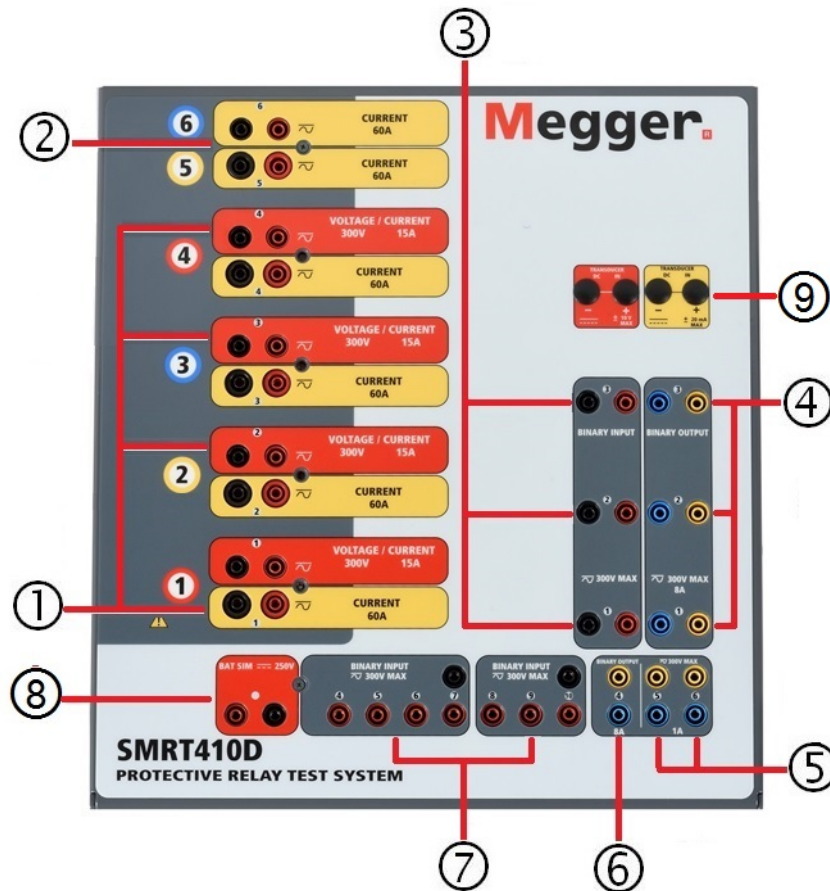

Figure 397 Top Panel SMRT410D (Pictured with Floating Returns and DIGEN Options)

#### 1.1.1 Top Panel

1. **Voltage/Current Generator Module (or VIGEN) ①** – There is four available slots for the VIGEN Modules. The slots are numbered 1 to 4 from bottom to top, with the topmost VIGEN numbered 4. The four voltages and currents are noted by the red and yellow surrounding each output channel. Phases A, B, C and D Voltage Channels (V1, V2, V3 and V4) are denoted by the red color. Phases A, B, C and D Current Channels (I1, I2, I3 and I4) are denoted by the yellow color. When the voltage generators are converted to current generators, they will change on the STVI display as V1 = I5, V2 = I6, V3 = I7, and V4 = I8.
2. **Current/Current Generator Module (or DIGEN) ②** – There is one available slot for the DIGEN Module. SMRT410D with the DIGEN option, the VIGEN Modules are numbered 1

- to 4 from bottom to top, with the topmost VIGEN numbered 4. The DIGEN current channels are numbered 5 and 6. When the voltage generators are converted to current generators, they will change on the touch screen display as V1 = I7, V2 = I8, V3 = I9, and V4 = I10.
3. **Binary Inputs** – there are 10 Binary Inputs located on the top panel ③ and ⑦. To serve a wide range of test applications the binary inputs have different voltage thresholds. Depending on the age of the unit, for typical test applications, binary inputs 1 and 2 have programmable voltage thresholds from 2 to 150 V. Older units will have a fixed voltage threshold of 5 V AC/DC. Binary input 3 has a fixed threshold of 5 V. For **GPS End-to-End synchronized relay testing Binary 1** may relate to a remote trigger pulse from a GPS satellite receiver for external initiation, or the output of an **IRIG-B** signal (see use of **Wait IRIG-B** input using RTMS Sequencer test). There are an additional 7 binary inputs ⑦. To monitor TTL signals binary inputs 4 through 6 have a fixed threshold of 3 V. Binary inputs 7 and 8 have fixed thresholds of 5 V, and binary inputs 9 and 10 have fixed threshold of 30 V (for “noisy” test environments). In addition to serving as Timer/Monitor inputs, the Binary Inputs may be programmed to trigger binary output sequence(s). Binary Inputs can also be programmed using Boolean logic for more complex power system simulations.
  4. **Binary Outputs** – there are 6 Binary Outputs located on the top panel ④, ⑤ and ⑥. Each Binary Output can be configured as Normally Open or Normally Closed contacts providing logic to the device under test. The Binary Outputs 1 to 4 ④ and ⑥ can switch up to 300 VAC or 250 VDC with 8 A continuous. The programmable wait duration is from 1 ms to 10,000 ms. Binary Outputs 5 and 6 ⑤ are the high speed binary outputs have an AC/DC Voltage Rating of 400 V peak, I<sub>max</sub>: 1 A, with a Response Time: < 1ms typical. An LED indicates the status of the contact. ON indicates closed, and OFF indicates open.
  5. **Battery Simulator** ⑧ – the SMRT410D provides a battery simulator with a continuously variable DC output voltage from 5 to 250 V, at 100 W (4 A Max) providing logic voltage for solid-state relays. When powered ON, the LED above the output terminals illuminates.
  6. **Transducer Input Terminals** ⑨ - The SMRT410D may have the optional transducer input terminals. The transducer hardware “T” option can either be ordered with the new test set or later as a factory hardware upgrade. If the unit is ordered without the optional inputs, the holes are plugged. The DC IN Voltage range is ± 10 VDC. There are two ranges with the DC IN A: ± 0 to 1 mA or ± 4 to 20 mA.

### 1.1.2 Front Panel:



Figure 398 SMRT410D Front Panel

1. **Incoming Power/Line Cord** ① – the input line cord, ground terminal, are mounted on the front panel of the test set.

#### Input Line Cord



The test set is equipped with a line cord, which connects to the male connector on the front panel. Verify the input voltage rating on the front panel before connecting the line cord to the power source.

2. **Earth Ground Jack** ② – use this terminal to connect chassis ground to earth ground.



A chassis ground (earth) point on the front panel is provided as an additional safety ground.

3. **POWER ON/OFF Switch** ③ – used to switch unit on and off.
4. **ISOLATED** ④ For IEC 61850 testing connect IEC61850/OUT port to the substation bus or to the relay under test to receive and send GOOSE messages. Connect the ISOLATED port to the PC. When used with the Megger GOOSE Configurator in the RTMS, the SMRT can provide high speed testing of IEC 61850 relays and substations by subscribing to GOOSE messages and mapping to the binary inputs. In addition, it can simulate system conditions such as circuit breaker operation by publishing GOOSE messages mapped to the SMRT binary outputs. With the PC running Megger GOOSE Configurator (MGC) and connected to the ISOLATED port, the operator can “sniff” the substation network from the IEC 61850/OUT port through the ISOLATED port with the SMRT serving as the firewall. With this design the operator cannot accidentally trip off the substation or infect a PC virus into the substation LAN.

5. **PC/IN** ⑤ Ethernet Port is the primary PC connection port for automated relay testing. This port supports MDI/MDI-X auto crossover configuration, which means both standard and “crossover” Ethernet cables may be used. Use this port for standard automated relay testing. This port provides the optimal method for downloading EMTP files, DFR streaming, and updating the unit’s firmware as required. For multiple unit operation, the unit providing the OUT link provides the primary phase reference to all units “downstream.” For multiple unit operation connect the OUT port to the downstream SMRT unit IN port. RTMS will automatically configure when the units are powered up.
6. **IEC61850/OUT** ⑥ Ethernet Port is a 10/100BaseTX port and is primarily used to interconnect multiple SMRT units together for synchronous multi-unit operation. It is also used to provide access to the substation IEC 61850 network. For multiple unit operation, the unit providing the OUT link is providing the primary phase reference to all units “downstream.” With the PC connected to the PC Port, the SMRT and the PC share the same Ethernet network connection, and thus will not have secure isolation from each other. When testing IEC 61850 devices connect the PC to the ISOLATED Ethernet port to isolate the PC from the IEC 61850 substation bus.
7. **USB Interface** ⑦ There is two type A ports available. This port is primarily used to update the firmware in the SMRT as well as update RTMS using a USB memory stick. It may also be used to download test results from the SMRT for download onto another PC with PowerDB software for storage or printing. In addition, the user can use a USB keyboard, as well as a mouse, in conjunction with the STVI. Keyboard and/or mouse are not provided with accessories.
8. **USB (TO PC) Interface** ⑧ – The (TO PC) USB Interface requires a Type B “downstream” connector and is primarily used as a communication and control port when used with a PC and Megger RTMS for automated relay testing. A USB cable is not provided with the test set or in the optional accessories. For computer control, an Ethernet cable is provided. However, should the user desire to use the USB port for communication any standard USB A/B cable can be used with the unit. May be used when isolation is required for a secure substation access between the SMRT and the IEC 61850 substation network.

## 1.2 Input Power

The input voltage rating may be from 100 to 240 VAC,  $\pm 10\%$ , 50/60 Hz. The maximum input power is 1800 VA. The input is protected by a power ON/OFF switch/circuit breaker.

### 1.2.1 Input Power Cord

Depending on the country, the power cord can come with a NEMA 5-15 male connector, a CEE 7/7 Schuko two prong connector, with International Color Coded pig-tail wires (light blue, brown and green with yellow stripe) with the insulation jacket stripped ready for installation of the appropriate male connector, or with UK power cord.

Model SMRT410 **XXP2X0A**XXX comes with a North American power cord (part number 620000).

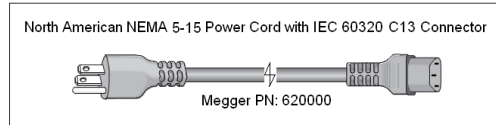

Model SMRT410 **XXP2X0E**XXX comes with a Continental Europe power cord (part number 50425).

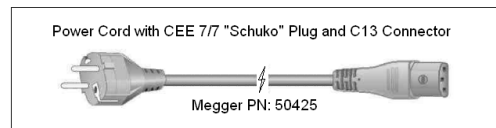

Model SMRT410 **XXP2X0I**XXX comes with an International Color Code power cord. The cord, part number 15065, is ready for wiring to the appropriate plug (depending on country). The following colors apply, Brown = Line, Blue = Neutral and Green/Yellow = Ground.

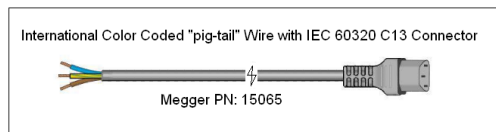

Model SMRT410 **XXP2X0U**XXX comes with a UK power cord (part number 90002-989).

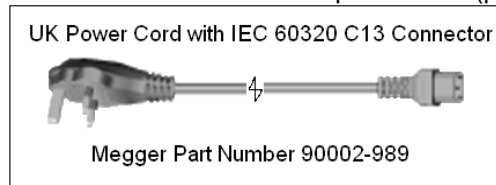

### 1.3 Voltage - Current Generator (VIGEN) and Double-Current (DIGEN) Modules

Voltages and Currents are noted by the red and yellow surrounding each output channel. Phases 1, 2, 3 and 4 voltage channels are denoted by the red color. Phases 1, 2, 3 and 4 current channels are denoted by the yellow color. The optional Double Current module includes two current channels phases 5 and 6 and are also surrounded by yellow. All outputs are independent from sudden changes in mains voltage and frequency and are regulated so changes in load impedance do not affect the output. All amplifier outputs are isolated or floating. The SMRT units can be ordered with the amplifier common returns tied to chassis ground as an option.

#### 1.3.1 Convertible Voltage/Current Amplifier

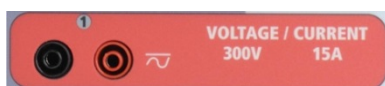

The SMRT PowerV™ voltage amplifier provides a flat power curve from 30 to 150 V in the 150 V range to permit testing of high current applications such as panel testing. The following outputs are provided.

Voltage Range	Power/Current (Max)
30.00 V	150V A @ 5.0 A
150.00 V	150V A Constant Output Power from 30 to 150 V
300.00 V	150V A @ 0.5 A

Voltage Amplifier in Current Mode :

The voltage amplifier is convertible to a current source with the following output capability. Output power ratings are specified in RMS values and peak power ratings.

Output Current	Power	Max V	Duty Cycle
5 A	150 VA (212 peak)	30.0 V RMS	Continuous
15 A	120 VA	8.0 V RMS	1.5 s or 90 cycles

With a 4 channel SMRT410D unit, convertible channels in conjunction with the four main current channels, provides 8 currents. When the voltage generators are converted to current generators, they will change on the touch screen display as current phases 5, 6, 7, and 8. If the optional Double-Current (DIGEN) module is installed, the convertible channels will be labeled current phases 7, 8, 9, and 10.

 The voltage amplifier output is protected from short circuits and thermally protected against prolonged overloads. In case of a short circuit or a thermal overload, the amplifier will automatically turn off, and a message to the user will be displayed indicating which condition exists.

### 1.3.2. Current Amplifier



The SMRT410D current amplifier delivers maximum compliance voltage to the load constantly during the test, and range changing is done automatically, on-the-fly, under load. This ensures better test results, saves time by not having to turn the outputs off to change output taps or ranges, and unlike single range current amplifiers insures a higher compliance voltage at lower test currents. Constant power output in many cases eliminates the need to parallel or series current channels to test high burden relays. The following are typical output current and associated available compliance voltage values. The per channel output current and power ratings are specified in AC RMS values and peak power ratings. Specified duty cycles are based upon typical room temperature.

Output Current	Power	Max V/Duty Cycle
1 A	15 VA	15.0 V RMS Continuous
4 A	200 VA (282 peak)	50.0 V RMS Continuous
15 A	200 VA (282 peak)	13.4 V RMS Continuous
32 A	200 VA (282 peak)	6.25 V RMS Continuous
60 A	319 VA (424 peak)	5.00 V RMS 1.5 s or 90 cycles
DC 200 W		

 The current amplifier output is protected from open circuits and thermally protected against prolonged overloads. In case of an open circuit or a thermal overload, the amplifier will automatically turn off, and a message to the user will be displayed indicating which condition exists.

## 1.4 Binary Inputs and Outputs

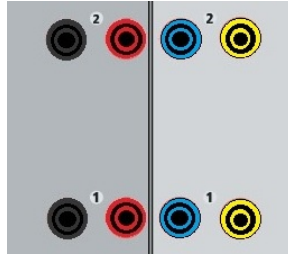

Figure 399 Binary Inputs and Outputs 1 and 2

Binary Inputs and Outputs are clearly marked and logically grouped. The Binary Inputs are used to monitor relay trip contacts for performing pickup and dropout tests as well as for performing timing functions. The Binary Outputs are used to simulate normally open/normally closed contacts for testing breaker failure schemes, or similar power system operations. In addition, they may also be used to switches AC/DC voltages and currents.



Figure 400 Binary Inputs 4 to 10 and Binary Outputs 4 to 6

### 1.4.1 Binary Inputs

The binary inputs are specifically designed to measure high speed operation of electro-mechanical, solid-state, and microprocessor-based protection relays. All binary Inputs default to Monitor Mode, Contact change of state, latched OFF.

If using RTMS to change a binary input from Contact change of state to Voltage Applied/Removed click on or touch the Input Type window and a sine wave will appear where the Contact icon was indicating. The input is now set for voltage sensing.

To change the binary input from Monitor mode to Timer Mode, click on or touch the Use as Monitor button and the display window will change to show Use as Trip, Latched, meaning the binary input is now set to stop the timer upon sensing the first contact closure (if the Input Type is set for contact) or upon sensing voltage if the Input Type is set to Voltage Sensing.

#### 1.4.1.1 Start, Stop, and Monitor Gates

In the SMRT410D there are up to ten identical, independent, programmable gate circuits that permit simple selection of the desired mode for timing or contact monitoring operation.

To monitor operation of the contacts or trip SCR in the device under test, a light is provided for each gate. The gate circuit is isolated for voltage-sensing and can monitor solid-state logic signals. Each light will illuminate once contacts close or voltage is applied to the gate.

#### 1.4.1.1.1 Dry Contacts Open

Timer stops or a continuity indicator goes out at the opening of normally closed contacts, or when conduction through a semiconductor device, such as a triac or a transistor, is interrupted.

#### 1.4.1.1.2 Dry Contacts Close

Timer stops or a continuity indicator glows at the closing of the normally open contacts, or upon conduction through a semiconductor device such as a triac or a transistor.

#### 1.4.1.1.3 Application or Removal of AC or DC voltage

This will either start the Timer or stop the Timer. The continuity indicator will glow (application) or darkens (removal) upon the application or removal of either an AC or DC voltage. To serve a wide range of test applications the binary inputs have different voltage thresholds. Depending on the age of the unit, for typical test applications binary inputs 1 and 2 have programmable voltage thresholds from 2 to 150 V. Older units will have a fixed threshold of 5 V AC/DC. Binary input 3 has a fixed threshold of 5 V. To monitor TTL signals binary inputs 4 through 6 have a fixed threshold of 3 V. Binary inputs 7 and 8 have fixed thresholds of 5 volts, and binary inputs 9 and 10 have fixed thresholds of 30 V (for “noisy” test environments). A higher threshold voltage helps to eliminate false triggers due to a noisy source. Lower thresholds allow the starting and stopping of timer from TTL voltage signals. The allowable voltage applied is 5 to 300 VAC or 5 to 300 VDC, current limiting resistors provide protection.

#### 1.4.1.1.4 The Timer can be started when turning on any selected generators.

1.4.1.1.5 The Timer can be started simultaneously with a change in Frequency, Phase Angle, or Amplitude. Also, it can be started simultaneously with a Voltage or Current waveform step.

### 1.4.2 Binary Outputs

Binary Outputs 1 and 2 are rated for 300 V at 8 A. Each Binary Output can be configured as normally open or normally closed contacts providing logic to the device under test. Binary Outputs 3 and 4 have a rating of 300 V AC/DC, 8 A and a maximum of 2000 VA breaking capacity (80 W DC), with a response time of less than 10ms. Binary Outputs 5 and 6 are high speed and have an AC/DC voltage rating of 400 V peak, 1 A and a response time typically less than 1ms.

The contacts may be programmed to open or close, thus simulating circuit breaker operation. The programmable wait duration is from 1 ms to 10,000 ms. A fused test lead (fused at 500 mA) is available as an optional accessory to help protect from blowing the internal fuse of binary outputs 5 & 6. The test lead is blue in color so that the user knows it applies to the blue binary outputs. The barrel holder of the test lead is CE marked with a 1000 V, CAT III rating, and marked FUSED 500 mA/1000 V/50 kA.

## 1.5 Battery Simulator



Figure 401 Battery Simulator (BAT SIM)

The SMRT410D includes a battery simulator that provides a variable DC output from 5 to 250 VDC rated at 100 W, 4 A max. User may select from normal setting values of 24, 48, 125, or 250 VDC, or enter the desired output voltage in the window provided, see the STVI Configuration Screen. The output is variable using the Control Knob, or the PC up/down cursor arrows (see the STVI section of the manual).



### CAUTION:

**NOTE:** DC voltage is ON and available when the output is turned on using the LCD touch panel or via software command. Do not plug or insert any test lead into the BATTERY SIMULATOR binding posts without first connecting the test leads to the load!

## 2.0 SETUP

### 2.1 Unpack System

Unpack the unit and check for evidence of any shipping damage. If there is any visual damage, immediately notify the freight carrier to make a damage claim and notify Megger of the damage.



### CAUTION:

**Potentially lethal voltages may be present on the output terminals. It is highly recommended the operator read the user manual thoroughly and understand the test set operation prior to turning power on.**

#### 2.1.1 Initial Start Up

1. If using RTMS on a PC, connect the **PC/IN** Ethernet Port on the SMRT410D unit to the PC Ethernet port.
2. Before connecting power to the unit, make sure the POWER ON/OFF Switch is in the OFF position (O). Plug the unit line cord into an appropriate power source and turn the POWER ON/OFF Switch to ON (I). As the SMRT unit goes through its power up sequence, in about a minute the STVI power up screen will appear, then the manual start up screen will appear.

## 2.2 Communication Ports

There are several communication ports. These ports are: two USB, three Ethernet, and an optional Bluetooth wireless port. To connect with Bluetooth, the activation code is 0000 (that is 4 zeros).

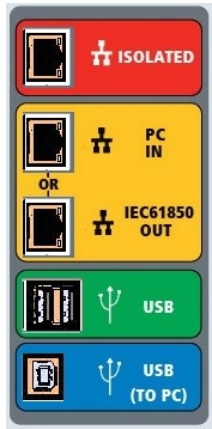

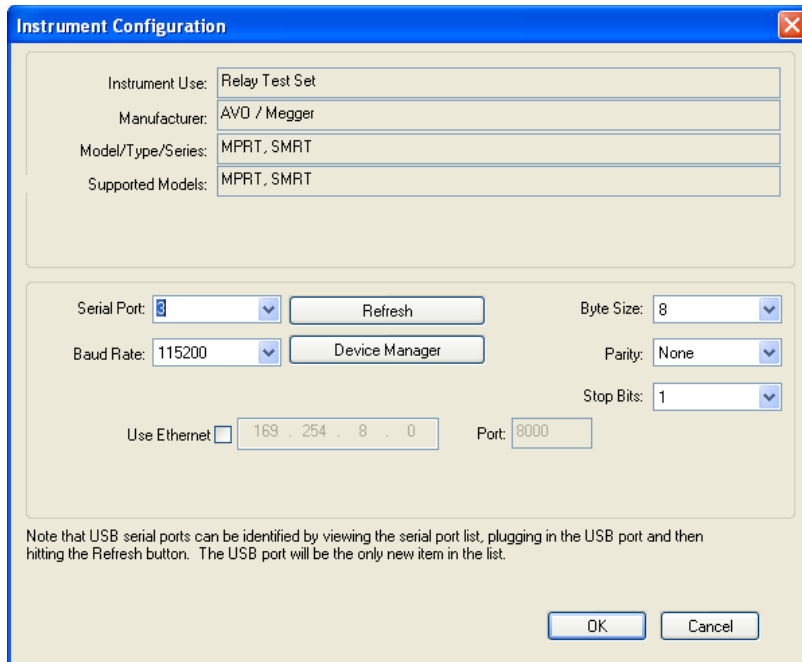

Figure 402 SMRT410D Communication Ports

### 2.2.1 USB 2.0 Interface

The USB Type A ports are intended for use with downloading RTMS, SMRT firmware, or stored PowerDB test results. A USB keyboard or mouse can also be used with the unit. USB TO PC Interface requires a Type B “downstream” connector and is primarily used as a communication and control port when used with a PC and RTMS (PC version) for automated relay testing. It is recommended that you use the Ethernet port for high speed communication and control of the SMRT unit. Using the USB port will require the user to configure the PC com port for USB

operation. Clicking on the Instrument Setup icon on the PowerDB tool bar , the Instrument Configuration Screen (shown in the following figure)



provides the user with access to the PC Device Manager screen. Click on the Device Manager button and navigate to the USB Ports file directory. Since the SMRT410D **defaults to a baud rate of 115,200**, the user will need to configure their USB output com port to match. Returning to

the Instrument Configuration screen the user will need to check off the Use Ethernet check box, and set the Baud rate, Byte Size and Stop Bits as shown.

### 2.2.2 PC/IN Ethernet Port

**PC/IN** Ethernet Port is the primary PC connection port for automated relay testing. This port supports MDI/MDI-X auto crossover configuration, which means both standard and “crossover” Ethernet cables may be used. Use this port for standard automated relay testing. This port provides the optimal method for downloading EMTP files, DFR streaming, and updating the unit’s firmware as required. For multiple unit operation, the unit providing the OUT link provides the primary phase reference to all units “downstream.” For multiple unit operation connect the OUT port to the downstream SMRT unit IN port. RTMS will automatically configure when the units are powered up.

#### 2.2.2.1 Setting **SMRT** IP Address for Operation with a PC

With the Ethernet cable supplied with the unit, connect the **PC/IN** Ethernet Port on the SMRT unit to the PC Ethernet port. Turn the test set on. As the SMRT unit goes through its power up sequence, in less than a minute the RTMS power up screen will appear. If using the PC version of RTMS it will auto-detect the SMRT unit connected to the PC. Once it auto-detects the unit, and determines the configuration of the SMRT unit connected, the Manual screen will appear. The unit might not auto detect due to firewall settings. In this case the firewall can be turned off or you can enter the IP address directly using the PowerDB instrument configuration screen by clicking

on the Instrument Setup icon on the PowerDB tool bar . From the Instrument Configuration Screen, shown in the following figure, click off the check mark in the Auto Discover Unit box.

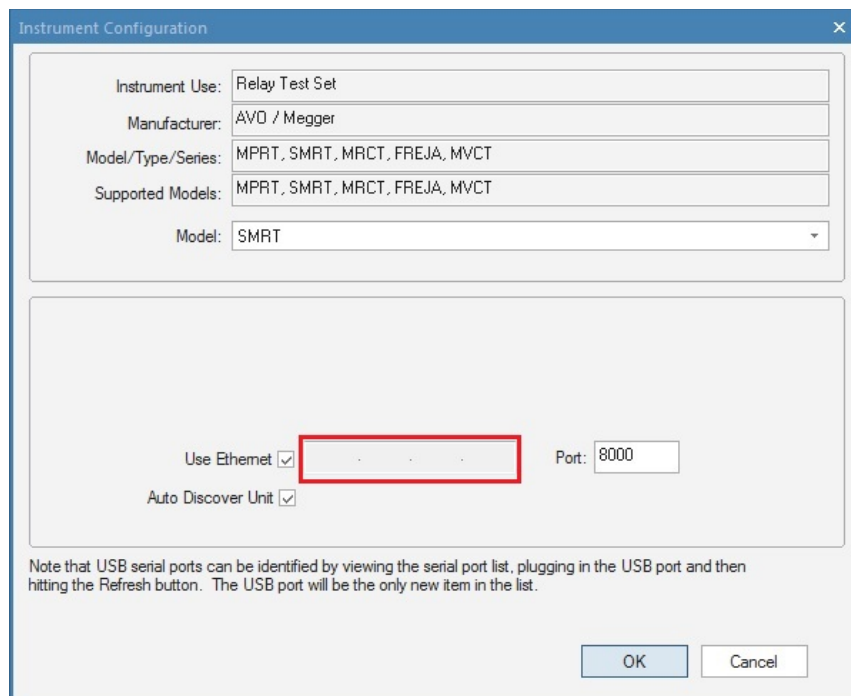

Figure 403 PowerDB Instrument Setup Screen

With the Auto Discover Unit box checked RTMS should find the unit. If not, the IP address can be entered in the box highlighted in the figure above. Also note that the IP address is also printed on

the unit nameplate sticker. If the unit is on a network with a DHCP server, the user must use the Auto Discovery mode.

### 2.2.3 ISOLATED Ethernet Port

For IEC 61850 testing connect IEC61850/OUT port to the substation bus or to the relay under test to receive and send GOOSE messages. Connect the ISOLATED port to the PC. When used with the Megger GOOSE Configurator software, the SMRT unit can provide high speed testing of IEC 61850 relays and substations by subscribing to GOOSE messages and mapping to the binary inputs. In addition, it can simulate system conditions such as circuit breaker operation by publishing GOOSE messages mapped to the SMRT binary outputs. With the PC running Megger GOOSE Configurator and connected to the ISOLATED port, the operator can “sniff” the substation network from the IEC 61850/OUT port through the ISOLATED port with the SMRT unit serving as the firewall. With this design the operator cannot accidentally trip off the substation or inflict a PC virus into the substation LAN.

### 2.2.4 IEC61850/OUT Ethernet Port

The IEC 61850/OUT Ethernet Port is a 10/100BaseTX port and is primarily used to interconnect multiple SMRT units together for synchronous multi-unit operation. It is also be used to provide access to the substation IEC 61850 network (when enabled). The SMRT410D with the IEC 61850 option provides selectable priority, VLAN-ID, and meets the IEC 61850-5 standard Type 1A, Class P 2/3, for high speed trip and reclose simulations. For multiple unit operation, the unit providing the OUT link provides the primary phase reference to all units “downstream.” With the PC connected to the PC Port, the SMRT and the PC share the same Ethernet network connection, and thus will not have secure isolation from each other. When testing IEC 61850 devices connect the PC to the ISOLATED Ethernet port to isolate the PC from the IEC 61850 substation bus.

#### 2.2.4.1 Setting SMRT IP Address for Networks or IEC 61850 Operations



The SMRT410D may be controlled over a network. This provides remote control of the SMRT410D over any distance allowing one PC to control at least two units simultaneously, such as in end to end testing. *Connecting the SMRT410D to a Local Area Network or a Wide Area Network could permit unauthorized operation of the unit.*

Through the PC IN Ethernet port, the SMRT410D integrates into a network just like a PC or server. Using this feature requires the user to setup the IP configuration of the SMRT410D for their LAN. Note that the SMRT410D when turned on will automatically search for and acquire a network address if connected to a network. If it fails to automatically acquire an address check to make sure you are properly connected using a standard Ethernet cable. **Do not** use a “cross-over” Ethernet cable (a cross over cable is designed for use from your PC to the test set, not to a network). If the unit still fails to acquire an address, then there may be other issues. This will require assistance from your company’s information management department.

## 3.0 Current Sources

### 3.1 Parallel Operation

Each SMRT410D current amplifier can provide 32 A continuous, and up to 60 A for 1.5 s or 90 cycles for testing instantaneous trip elements. When more than 32 A single phase is required for long durations, or 60 A for testing instantaneous elements, three or more current channels may be connected in parallel to provide 90 up 180 A continuous, and from 180 up to 360 A for short durations.

! Note: If an **F** or a **C** appears in the 5<sup>th</sup> digit of the style identification number (i.e., 40P2**F**0A0S1) the current returns are floating (isolated from each other and ground). Those units with a style number **G** or a **E**, the current returns are common together internally and connected to earth ground.

To parallel the current channels of the unit, perform the following:

If using the sleeved multi-lead current test leads (part number 2001-396), all the black return leads are interconnected together inside the sleeve so they will all share the return current together. Connect each current channel to the relay under test (both red and black terminals to the load). Each Megger test lead is rated 32 A continuous. If using test leads other than those supplied by Megger, ensure that the wire has sufficient size to carry the test current.

! For the earth grounded common return (G or E) units, there is an internal common ground between the current channel return terminals. If using separate individual test leads, all the return leads will need to be common together at the load as shown in the following figure. By not connecting a return lead to all the current channels in use, part or all the return current will be forced through the internal ground. That means with 6 channels in parallel up to 360 A could be forced through the internal common ground and will cause damage to the internal common returns. Therefore, it is important that parallel connections must be made at the relay. See the following figure.

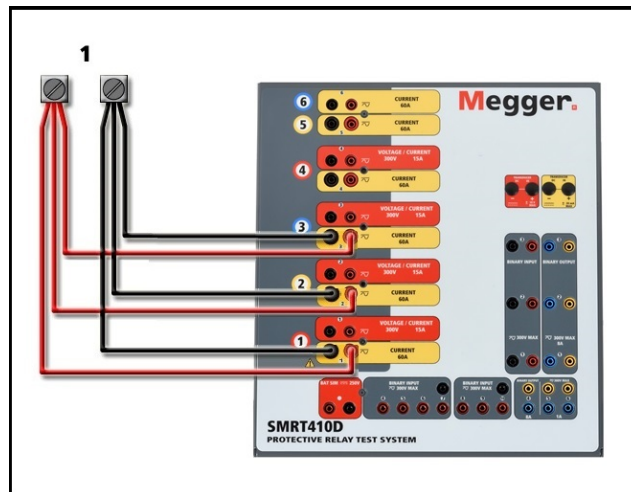

Figure 404 Parallel of Three Current Outputs

### 3.1.1 Manual Test Screen - Single Phase Up To 360 A

! Note: The 360 A stated in the title is based upon a 4 V/6 I configuration. If your unit is a 4 V/4 I configuration then the maximum output capability of the unit is 240 A.

For ease of use and operator convenience, go to the Configuration screen and select the Operating Mode of **4 Voltages – 1 Current @ 360A** (a 4 channel configuration will offer **4 Voltages – 1 Current @ 240A**). When you return to the manual test screen there will be one current channel displayed, as shown in the following figure.

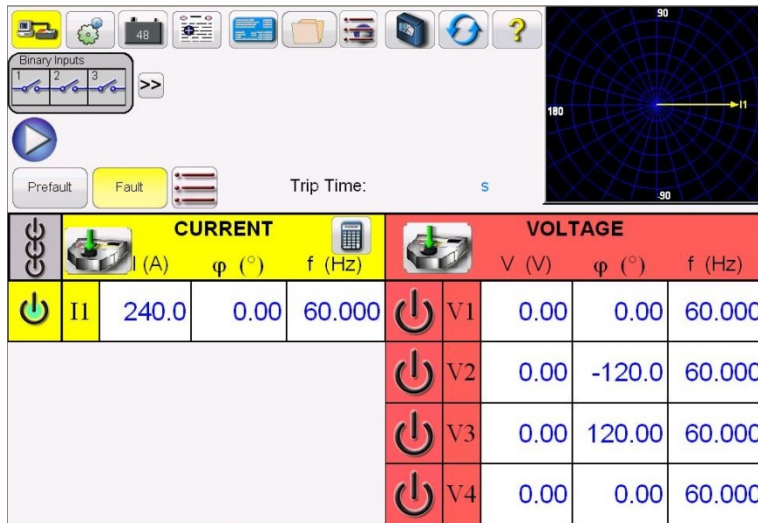

Figure 405 Manual Test Screen – Single Phase Operation

RTMS will automatically set all available currents in phase with each other and divide the current equally between the current amplifiers. When setting an output, simply enter the value of the desired output current. For example, for a 6 current channel output unit and a test current of 180 A, each current amplifier will be providing 30 A. The current can also be phase shifted. Simply enter the desired phase angle and all currents will be phase shifted together.

If two current channels are to be used in parallel, leave the unit in the default configuration. Connect the two current outputs to the load as shown in the following figure.

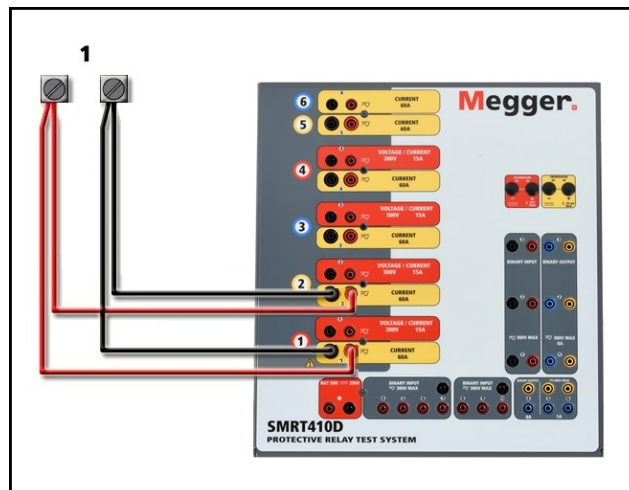



Figure 406 Two Currents in Parallel

Set current channels 1 and 2 to one-half of the output requirement. **Be sure and reset current channel #2 to 0 degrees so that it will be in-phase with current channel #1.** With both current channels selected, turn output on by pressing or clicking on the ALL ON/OFF button. Always use the ALL ON/OFF button to turn both current channels on and off together. For manually ramping outputs, if using the PC version of RTMS the  $\uparrow\downarrow$  buttons will be displayed. If using the touch screen, the Control Knob icon  will be displayed. Pressing either of these two will present the user with a window to select the desired level of increment for manually ramping the outputs,

the desired channel(s) to be ramped, and what is to be adjusted (amplitude, phase angle or frequency).

### 3.2 Currents in Series Operation

Two current channels may be connected in series to double the available compliance voltage. High impedance electromechanical ground (earth) overcurrent relays have always been difficult to test at high multiples of tap due to the winding impedance and saturation characteristics. The peak voltage required can exceed the maximum output voltage of one SMRT410D current output channel, depending on the required test current. By connecting two current outputs in series, the compliance voltage is doubled, providing higher test currents through the load. There are two methods to series currents together.

**!** Note: If an **F** or **C** appears in the 5<sup>th</sup> digit of the style identification number (i.e., 40P2**F**0A0S1) the current returns are floating (isolated from each other and ground). Those units with a style number **G** or **E** the current returns are common together internally and connected to earth ground.

For the floating output (F or C) models connect the two current amplifiers in a “push-push” configuration as shown in the following figure.

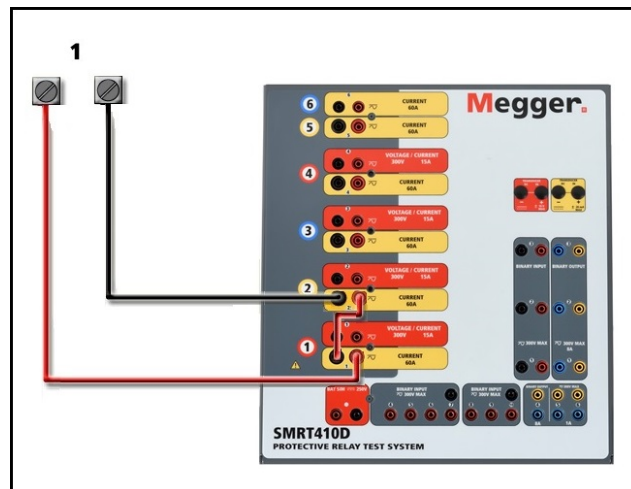



Figure 407 Series Two Currents with Floating Output Unit

The two current channels that are to be used in series set each to the same test current magnitude, and phase angle. Select both current channels and turn output on by pressing or clicking on the ALL ON/OFF button. Always use the ALL ON/OFF button to turn both current channels on and off together. For manually ramping outputs, if using the PC version of RTMS the

↑↓ buttons will be displayed. Using the touch screen the Control Knob icon  will be displayed. Pressing either of these two will present the user with a window to select the desired level of increment for manually ramping the outputs, the desired channel(s) to be ramped, and what is to be adjusted (amplitude, phase angle or frequency).

To series the current channels of the common grounded returns (G or E) unit, perform the following:

Using the current channel test leads, connect the Red output terminals of the two current channels to the relay under test. Even though the two returns associated with the current

channels are connected internally with the common returns, place a jumper as shown. This will ensure that the internal common leads will not be damaged.

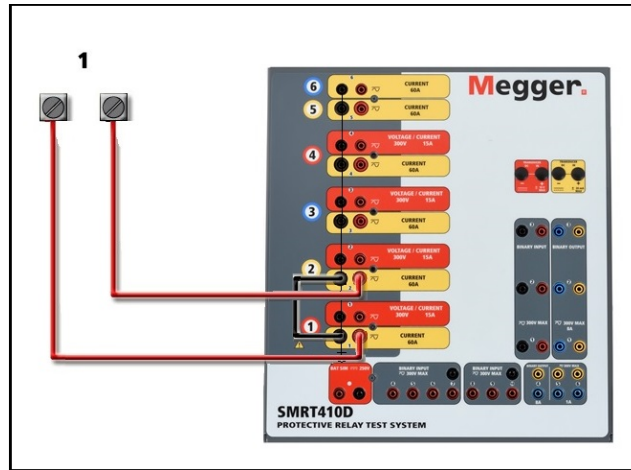



Figure 408 Series of Two Current Channels with Grounded Common Returns

**!** NOTE: One current channel should be set to 0 degrees and the other current channel should be set to a phase angle of 180 degrees so that the two compliance voltages add across the load. DO NOT attempt to series more than two currents together on a grounded common returns unit.

The two current channels that are to be used in series set each to the same test current magnitude. Initiate the two current channels simultaneously by pressing the ALL ON/OFF button. Always use the ALL ON/OFF button to turn both current channels on and off together. For manually ramping outputs, if using the PC version of RTMS the  $\uparrow\downarrow$  buttons will be displayed.

Using the touch screen the Control Knob icon  will be displayed. Pressing either of these two will present the user with a window to select the desired level of increment for manually ramping the outputs, the desired channel(s) to be ramped, and what is to be adjusted (amplitude, phase angle or frequency).

#### 4.0 Voltage Sources

##### 4.1 Outputs Summed Together

Two voltage channels may be used to sum the voltage outputs to obtain higher than rated voltage provided the load is ungrounded. Connect the load between the voltage channel posts, set  $V_1$  Phase to  $0^\circ$  and set  $V_2$  Phase to  $180^\circ$ . The voltage outputs will add so the total voltage is the sum of the two voltage amplitudes,  $V_1$  and  $V_2$  as can be seen in the picture below.

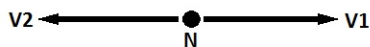

**!** Note: If an **F** or **C** appears in the 5<sup>th</sup> digit of the style identification number (i.e., 40P2**F**0A0S1) the voltage returns are floating (isolated from each other and ground). Those units with a style number **G** or **E** the voltage returns are common together internally and connected to earth ground.

For the floating common units, the user must connect the associated voltage channels black common returns together, when series operation is required (see the following figures). Remove

external commons when testing is completed. DO NOT attempt to series more than two voltage channels together.

Initiate the two voltage channels simultaneously by pressing the ALL ON/OFF button. Always use the ALL ON/OFF button to turn both voltage channels on and off together. For manually ramping outputs, if using the PC version of RTMS the  $\uparrow\downarrow$  buttons will be displayed. Using the touch screen the Control Knob icon  will be displayed. Pressing either of these two will present the user with a window to select the desired level of increment for manually ramping the outputs, the desired channel(s) to be ramped, and what is to be adjusted (amplitude, phase angle or frequency).

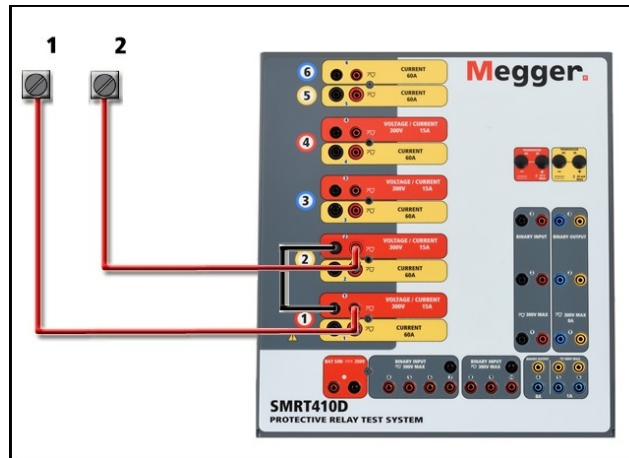

Figure 409 Series of Voltage Channels for Floating Ungrounded Common Returns

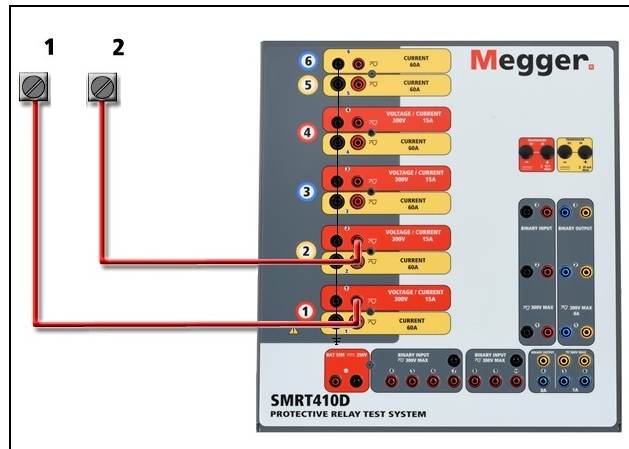

Figure 410 Series of Voltage Channels with Grounded Common Returns

#### 4.2 3 $\emptyset$ , 3-Wire, Open-Delta, and T-Connection

See section 3.4.2 in RTMS for detailed descriptions and use of the Open-Delta and T-Connections.

#### 4.2.1 Balanced Open Delta

The Open-Delta configuration is easy to use when a balanced three-phase source is required because the amplitude and phase relationship can be set directly. No calculations are necessary. When using the Open-Delta configuration, it is suggested to use voltage channel #1, designated  $V_1$ , and voltage channel #2, designated  $V_2$ , while the COMMON binding post is designated  $V_g$ . With this arrangement, the magnitude and phase angle of the potentials can be easily calculated and set. For the balanced three-phase condition  $V_{1g}$  and  $V_{2g}$  are equal in magnitude and separated by an angle of  $60^\circ$ . This is done by setting the  $V_1$  and  $V_2$  potentials equal in magnitude, setting  $0^\circ$  on  $V_1$  and  $300^\circ$  ( $60^\circ$  leading assuming that the default phase rotation is set to  $360^\circ$  Lag) on  $V_2$ , see the following figure.

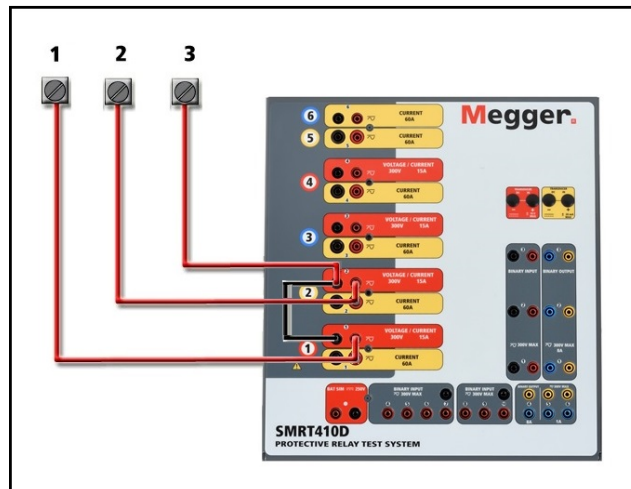

Figure 411 Three Phase Open Delta Connections

#### 4.2.2 T Connection

The second method of obtaining a three-phase, three-wire voltage source is the so-called T-Connection. The method is easier to use when obtaining an unbalanced, phase - to -phase fault simulation since it eliminates calculations. To reduce confusion when using the T-Connection, the voltage output #1 is designated  $V_a$  and its phase angle set at  $0^\circ$ , voltage output #2 is designated  $V_b$  and its phase angle set for  $180^\circ$ , and voltage output #3 is designated  $V_c$  and its phase angle is set for  $270^\circ$ . Any combination of balanced three phase faults or unbalanced phase-to-phase fault conditions can be easily simulated.

**!** NOTE: This method should not be used for low fault voltages, or used on solid state relays that may be sensitive to this type of connection (i.e., 5 V or less, or for testing ABB or Westinghouse type SKD relays).

#### 4.3 $3\phi$ , 4-Wire, Y-Connection

A three-phase, four-wire potential system can be provided using three output modules. This Y-Connection has the advantage of being able to supply a higher line-to-line voltage ( $1.73 \times$  phase-to-neutral voltage). It is ideally suited for simulating phase-to-ground faults. Voltage channel #1 is

designated as  $V_a$  with its phase relationship set for  $0^\circ$ . Voltage channel #2 is then designated as  $V_b$  and phase angle set for  $120^\circ$ . Finally, voltage channel #3 is designated  $V_c$  and phase angle set for  $240^\circ$  (for a 1-2-3 counterclockwise rotation).  $V_a$ ,  $V_b$  and  $V_c$  are connected to the voltage potential binding posts on the respective test sets.

**!** Note: If an **F** or **C** appears in the fifth digit of the style identification number (i.e., 40P2**F**0A0S1) the voltage returns are floating (isolated from each other and ground). Those units with a style number **G** or **E** the voltage returns are common together internally and connected to earth ground.

If using the sleeved multi-lead voltage test leads (part number 2001-395), all the black return leads are interconnected together inside the sleeve so they will all share the return together. Therefore, only one return lead is provided on the relay connection side of the sleeved leads (like the connections in the following figure).

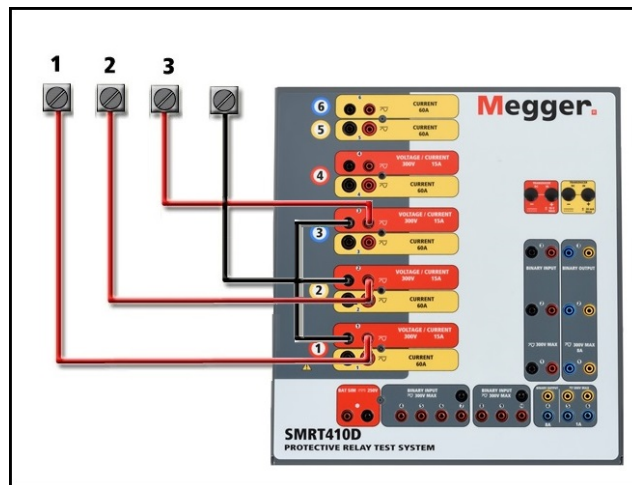

Figure 412 Three Phase Four Wire Test Connections

**!** For the earth grounded common return (G or E) units, there is an internal common ground between the voltage and current channel return terminals. Therefore, only one return lead is required for the voltage channels. If using separate individual test leads, for the floating common units the user must connect the associated voltage channels black common returns together as shown above using the jumper leads provided with the test leads option.