

**IEC 61850
GOOSE Interoperability**

Megger[®]



IEC 61850 GOOSE Interoperability

This page is intentionally blank.

IEC 61850 GOOSE Interoperability

Contents	Page
Executive summary	3
What is "Interoperability"?	3
Interoperability "before"	3
Interoperability with GOOSE	4
Interoperability with GOOSE messages	4
Interoperability created by GOOSE messages modified by other IEDs in the network	4
Interoperability created by different interpretation of "default values"	4
Interoperability created by different interpretation of SCL (xml) information (file importing/exporting)	5
Interoperability created by IEC 61850 engineering process	6
New tools and methods: MEGGER PC-GOOSER and GOOSER	6
MERGE and COMPARE (GOOSE Consistency Check)	6
What can I do if I do not have the new tools like GOOSER and PC-GOOSER?	7
What about VLAN?	10
VLAN care in the PC-GOOSER sniffer	10
Is your PC dropping the VLAN tag of GOOSE messages?	11
Temporary solutions for interoperability	11
Voltage translator for conventional technology	11
Conclusion	11
Product guide	12

IEC 61850 GOOSE Interoperability

Executive summary

Interoperability is one of the most misunderstood of all business terms. It is, however, one of the most important of all predictors of success or failure. In short, interoperability is the ability of diverse systems to work together effectively and efficiently. Interoperability is a property of a product or system, whose interfaces are completely understood, to work with other products or systems, present or future, without any restricted access or implementation.

There is absolutely no doubt that Interoperability facilitates valuable business connections across processes, between people and information, and among companies. Interoperability yields improved collaboration and ultimately increased productivity. Providing interoperability helps customers decrease complexity and better manage heterogeneous environments, while enhancing choice and innovation in the market. Importantly, the interoperability requirement of the IEC 61850 standard has beneficially increased the 'interoperability among different engineers' working for companies that are formally in competition. This increased communication among different vendors has contributed to the fact that GOOSE messaging can today be considered a working technology, even if problems still arise, like with any other technology.

With more than six years of field experience with IEC 61850 GOOSE communication in protection and control applications, it is possible today to list the main reasons for interoperability problems for multi- and single-vendor systems; however, the list of causes of interoperability failures would be longer than what is indicated in this document, especially if considering the cases found during the beginning of the use of GOOSE messages.

In order to commission substations with the new IEC 61850 technology, there is need to use some new tools and methods. The key for these tools and methods is, paradoxically, implicitly available in the IEC 61850 standard itself.

What is interoperability?

As detailed above, interoperability refers to a state when efficient and effective communication between two or more devices occurs. The IEC 61850 standard clearly aims at interoperability of IEDs from different manufacturers and defines the interoperability as the "ability to operate on the same network or communication path sharing information and commands."

When data sent by device A is not fully understood or received by device B, an interoperability failure occurs. This situation was common before the IEC 61850 standard, as most of numerical relays from different vendors had their own proprietary communication protocols. When the communication was not requested to perform real-time tasks (like the handling of protection signals for protection schemes), it was possible to solve this problem by using protocol converters.

Interoperability before

Interoperability is a word that commonly refers to numerical technology or numerical relays. Interoperability problems did and do exist even within the so called conventional technology, where the communication between different protection relays is in principle based on Boolean signals expressed in terms of DC voltage level. In a few words, one binary output (contact or similar) from one relay is connected to a binary input (optocoupler or similar) of another relay. The connection media is a couple of wires. This simple connection can produce interoperability problems as is detailed in this situation:

If the sending relay has the binary output polarized by the battery DC voltage, for instance 110 Vdc, and if the receiving relay has a binary input card with nominal DC voltage of 220 Vdc, the receiving relay can fail the reception of the signal. This is a frequent situation during the commissioning of substations, and it is commonly accepted that the binary input card of the receiving relay must be replaced.

Finding this problem and identifying its cause is a timeconsuming job because the testing engineer usually believes that the problem is located in other parts of the system he is testing, and the cause is identified only after any other "more probable cause" has been eliminated.

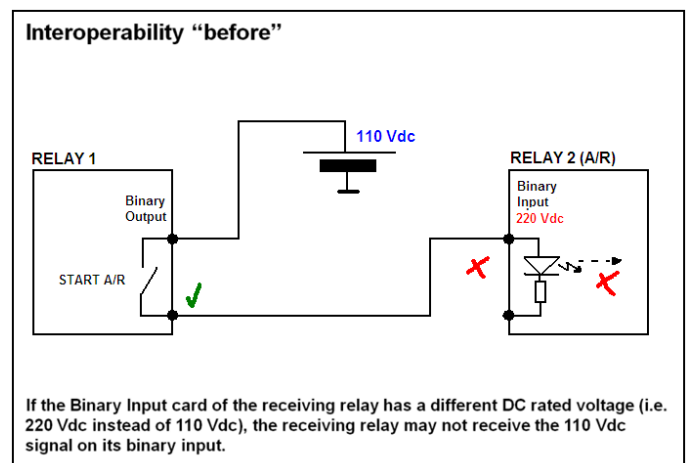

IEC 61850 GOOSE Interoperability

Interoperability with GOOSE

In the IEC 61850 GOOSE technology, the situation is very similar. The problem is identified after a time-consuming investigation concludes that the signal is not correctly received by the receiving IED. In a pictorial description, relay engineers usually describe interoperability failure with a similar sentence:

“The GOOSE message appears on the network. It can be seen with any network analyzer or dedicated GOOSE visualise. But the IED does not receive it.”

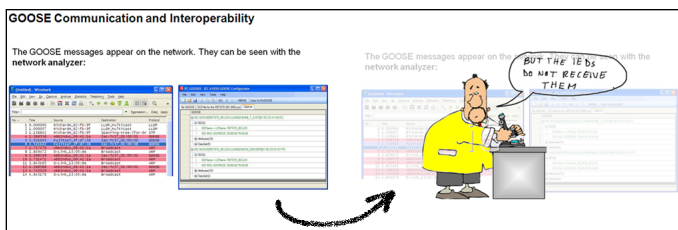

Interoperability with GOOSE messages

Interoperability problems created by GOOSE messages modified by other IEDs in the network

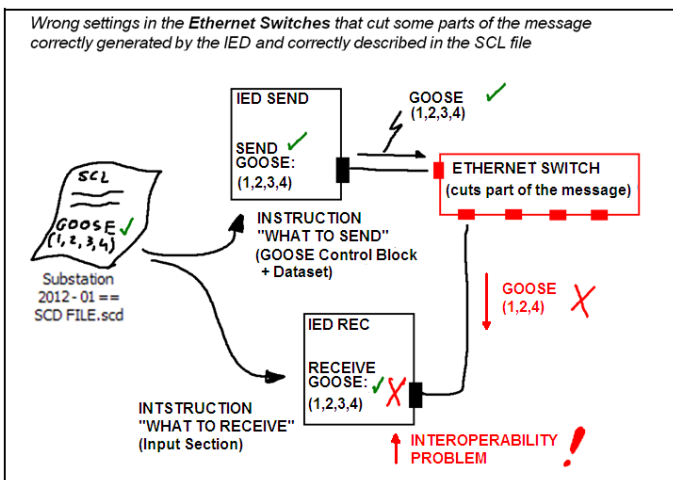

This interoperability problem can occur in multi-vendor but also in single-vendor applications. A typical example is illustrated in the VLAN tag of the GOOSE message, that is removed (or altered) by the switch (or switches), depending on the VLAN settings of the switch itself.

As the VLAN tag is a mandatory part of the GOOSE message, one IED has “the right” to refuse the GOOSE message if the tag is missing. One IEC 61850 TISSUE (nr. 290, VLAN ID) has been dedicated to this problem and the decision taken, put simply is that the IEDs are allowed to receive GOOSE messages with or without VLAN tag.

This means that depending on the firmware of the IED (issued before or after the TISSUE had been approved), some IEDs may receive the message with altered VLAN tag, and others may refuse it.

The simplest solution to this problem is to set the substation switches in such a way that the VLAN tags are not removed nor modified.

It is also recommended to always make use of the VLAN tag, even if in the horizontal communication different VLANs are not used, to make sure that all GOOSE messages are on the same VLAN (for instance VLAN 1). Depending on the switches used, they may have problems in handling the VLAN 0, but they should always be able to handle a VLAN different than zero. If all GOOSE messages have the same VLAN (001 for instance), it is always possible to set all the ports of all the switches to handle VLAN 1, with consequence that the VLAN tags of the messages should not be removed nor modified.

Interoperability problems created by different interpretation of “default values”

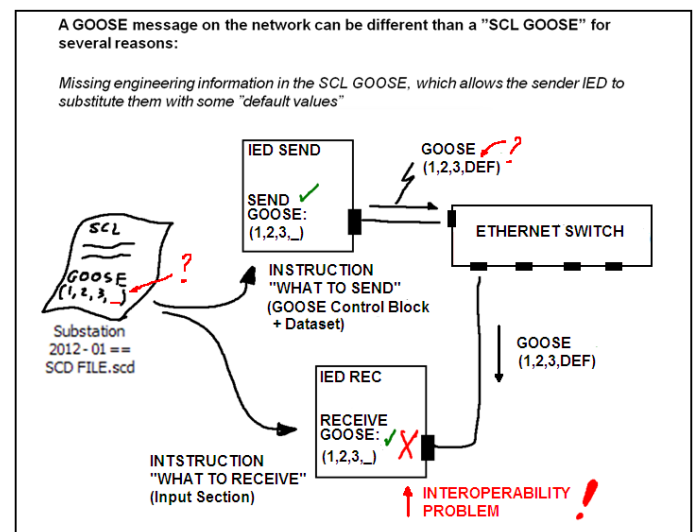

This type of interoperability problem is mainly due to a different interpretation from different vendors of the default values that must be given to the different attributes of the GOOSE message, when information is missing in the SCL file describing it. This interoperability problem has been seen in multi-vendor applications.

IEC 61850 GOOSE Interoperability

Even if the standard is quite clear on the default values, this type of interoperability problem has appeared often; the solution is usually a new firmware release of the IED. The problem could be in the sender IED (that sends the wrong default value) or in the receiving IED that is not able to understand that the default value received on the network is correct, even if its description on the SCL file for that value is empty.

This non-interoperability can be detected by comparing the SCL GOOSE information with the GOOSE information available on the network (Consistency check method).

The best method to avoid this problem is to always set all the possible attributes when defining the GOOSE message from the IEC 61850 engineering tool, and to not leave any field empty.

Interoperability problems created by different interpretation of SCL (xml) information (file importing/exporting)

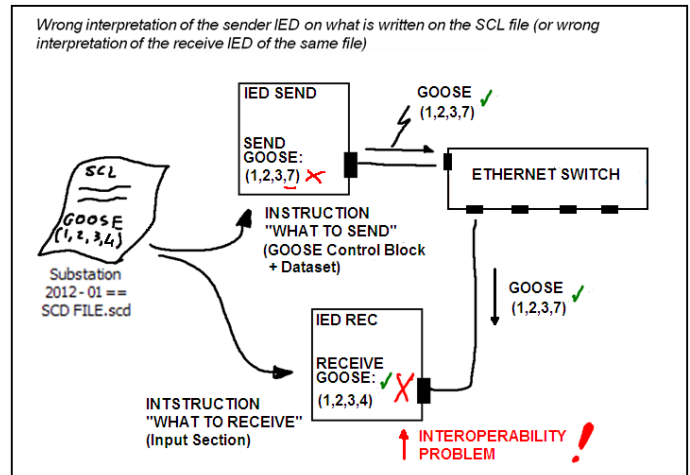

From what has been seen so far, unless there is an incorrect design (or bug) in the IEC 61850 GOOSE stack of one of the IEDs, this problem has occurred when using some non standard ASCII fonts in the SCL description of the GOOSE message, like "ä", "ö"; also the use of "space" has created problems. Not all engineering tools are very robust in checking that only correct fonts are used, and the definition of "correct font" has to be found in the XML file specification, as SCL files are XML files. This interoperability problem has been identified in multi-vendor applications.

Experience has shown that the best method to avoid these problems is to always make use of the basic ASCII characters, and never use spaces, when defining GOOSE messages in the engineering tools.

Usually the problem has been found in the sender IED, and if this is the case, the consistency check method against the SCL file detects the difference.

If the problem is in the receiving IED, the consistency check method doesn't help because the GOOSE message on the network is equal to the message on the SCL file. But in this case, everything points to the receiving IED and the manufacturer should be contacted to help in the investigation.

IEC 61850 GOOSE Interoperability

Interoperability problems created by IEC 61850 engineering process

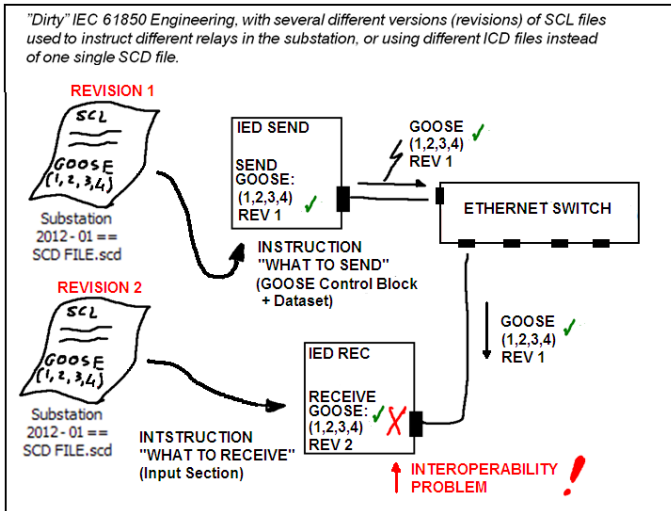

A typical example of this interoperability problem is a difference in the configuration revision of the GOOSE message. In the SCL file there is Configuration Revision 3, and the published GOOSE has configuration revision 2.

This means that the IEC 61850 horizontal communication has been modified at SCL file level, but maybe for that particular GOOSE message nothing has been changed. The engineering tool has anyway incremented the configuration revision, and the sender IED has not been updated with the new SCL file, but continues to work with the previous one.

This interoperability problem can occur in multivendor and also in single vendor applications (in single vendor applications, usually the IEC 61850 engineering process is simplified by the vendor tool, and the risk is minor). When this happens, typically the engineers say: "Everything was working fine before." This is a good indication that the problem could be there.

Also, the use of several SCL files (for example, several CID files for different IEDs rather than a single SCD file) increases the probability of generating this type of interoperability problem, not only related to different configuration revisions.

This is the most frequent source of interoperability problems identified so far, and the solution is not in any firmware update of the IEDs, but in a good revision of the IEC 61850 engineering process.

Again, the comparing method (consistency check) has never failed, so far, to identify the difference in what is published on the network and what is described in the SCL files.

New Tools and Methods: Megger Goose Configurator

MERGE and COMPARE (GOOSE consistency check)

Megger offers the MERGE and COMPARE algorithm that is able to identify all the differences between GOOSE messages available on the network and GOOSE messages described in SCL files. This method is more formally known as "GOOSE consistency check."

The MERGE and COMPARE algorithm is able to identify all the differences between the two messages, as in this example:

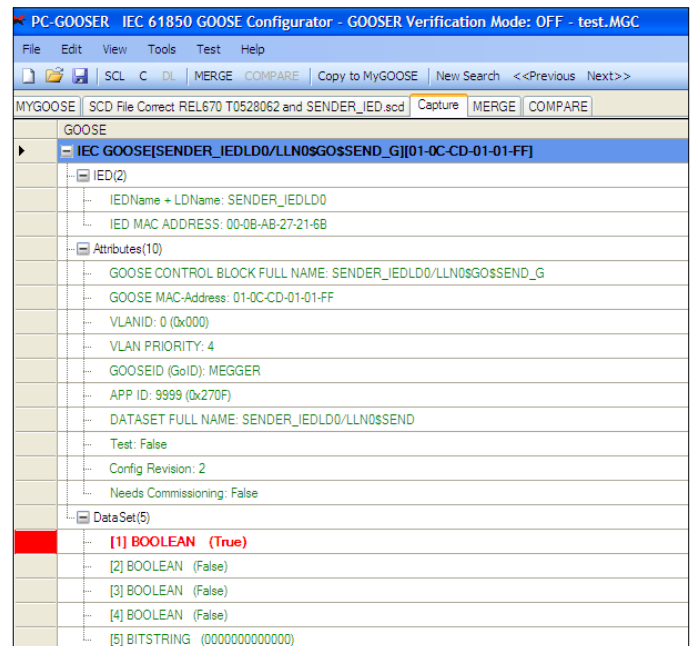

It is evident that the configuration revision of the GOOSE messages is different and also the DATASET is different, while all the other attributes are correct (i.e. they are equal). This is reasonable because, probably, the dataset of the GOOSE message has been really changed, and that is why the configuration revision is different. Sometimes it may happen that something is changed and then put back to its original value. Depending on the tool, the configuration revision may be increased even if in practice no significant value in the GOOSE message has been modified.

IEC 61850 GOOSE Interoperability

What can I do if I do not have the new tools like Megger Goose Configurator

Without dedicated tools for handling the comparison between GOOSE messages on network and in the SCL file, the job must be done manually, based on the engineer competence of IEC 61850 and on raw data.

It has to be noted that the comparison is not as simple as it may sound, because some GOOSE information available in the SCL file, is not available (or is shown differently) on the GOOSE frame and vice versa.

In the example below, the receiving IED does not receive the (apparently correct) GOOSE message, the MERGE and COMPARE algorithm detects the difference: Published (but not received) GOOSE:

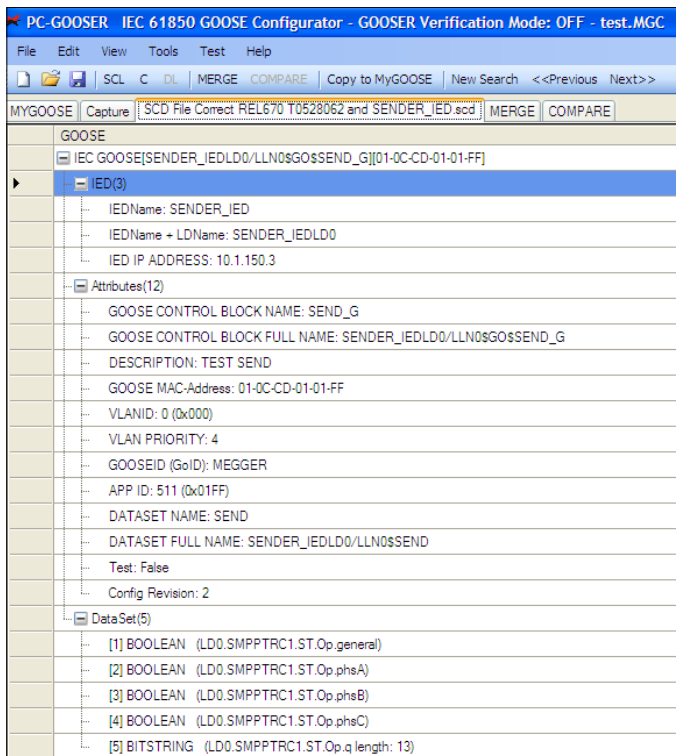

SCL GOOSE (used to engineer the sending and receiving IED):

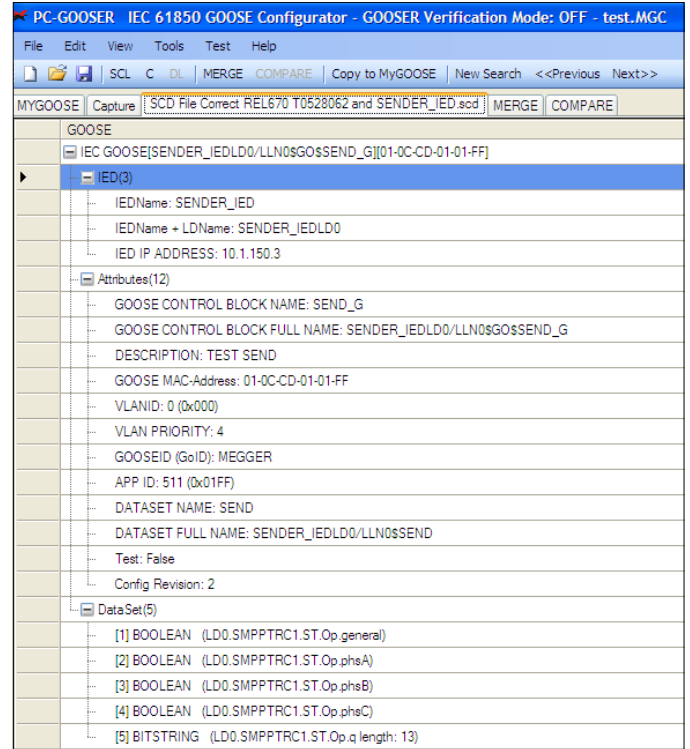

IEC 61850 GOOSE Interoperability

MERGE does not succeed (indicating that the two GOOSE messages are different):

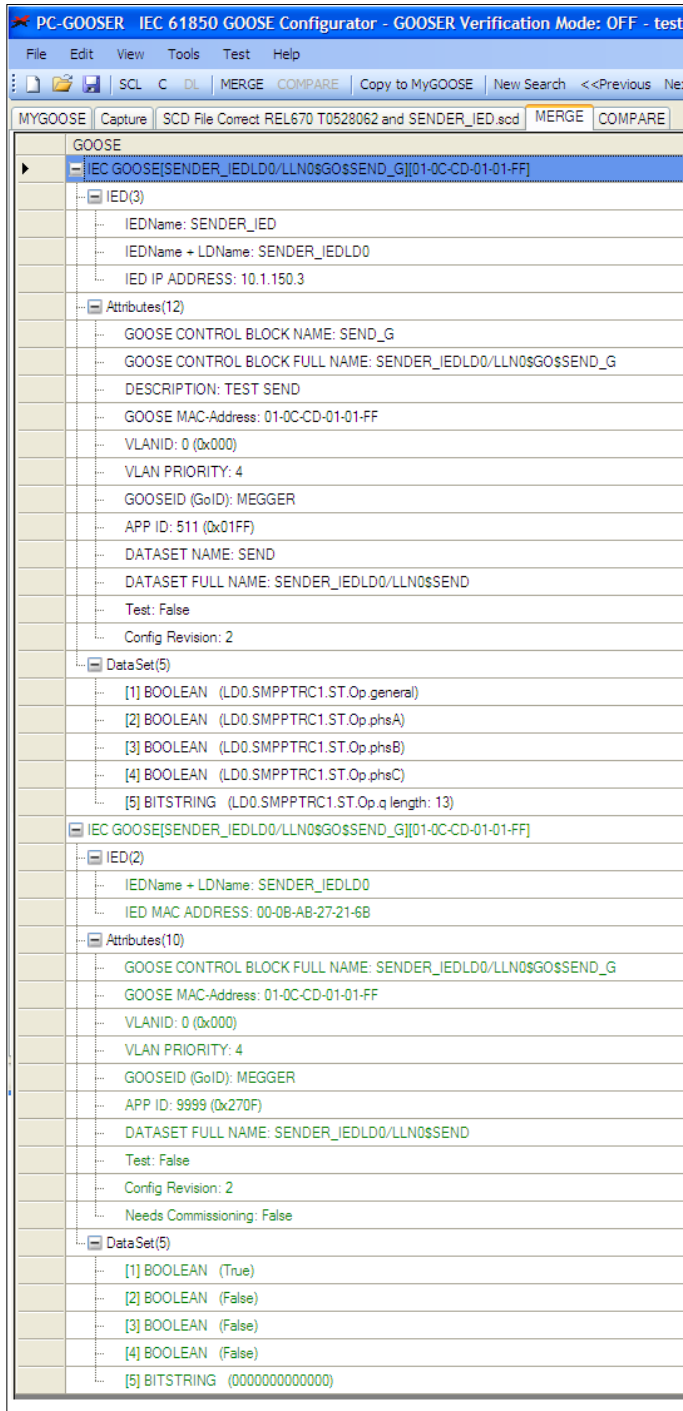

The COMPARE shows the difference (s) in the two GOOSE messages:

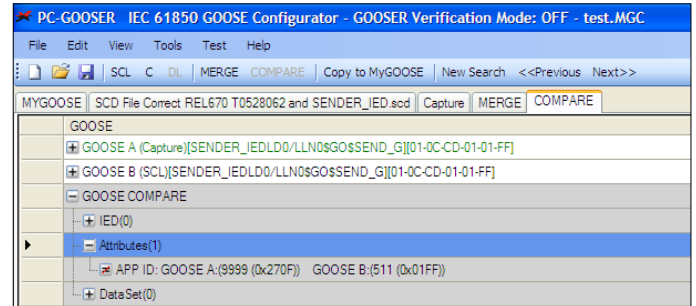

The APP ID of the published GOOSE (sender ID) is different than the APP ID that the receiver is expecting.

Why? The sending IED is wrongly interpreting the APP ID information. According to the standard, in the SCL file the APP ID is expressed in hexadecimal, but the IED (or the IED software tool) interprets it (probably) as decimal and hence sends it with the wrong information ("9999" looks like an overflow).

Without using Megger GOOSE Configurator, it is possible to detect this situation, but the way to the detection is much more difficult.

This is how the published GOOSE message is shown by the network analyzer Wireshark:

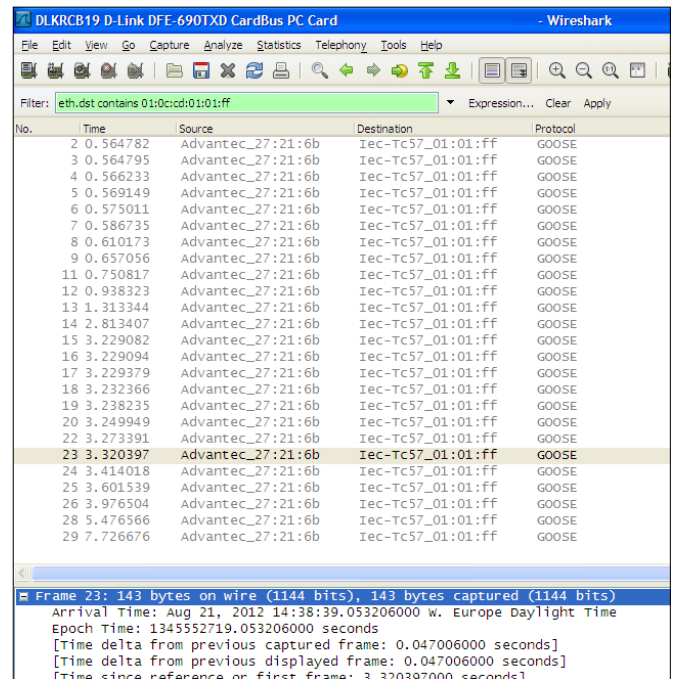

As the GOOSE message is a repeated message, the network analyzer shows the GOOSE message any time it is published on the network. If there are several different messages, unless special filters are used, it is very difficult to identify the correct one.

IEC 61850 GOOSE Interoperability

Megger GOOSE Configurator shows instead the same (repeated) message one time only, and gives the information when the dataset of this message (the value of the signal, using relay words) changes:

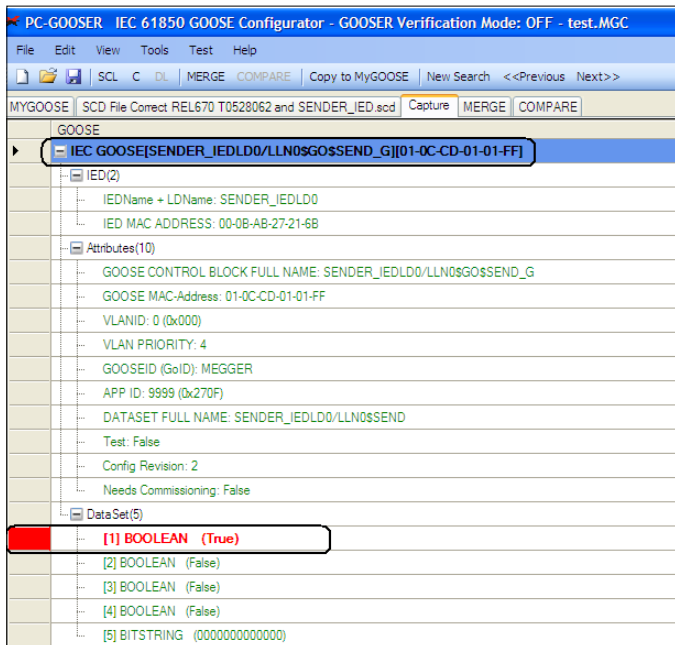

Once the GOOSE message is identified, on the analyzer it looks like this:

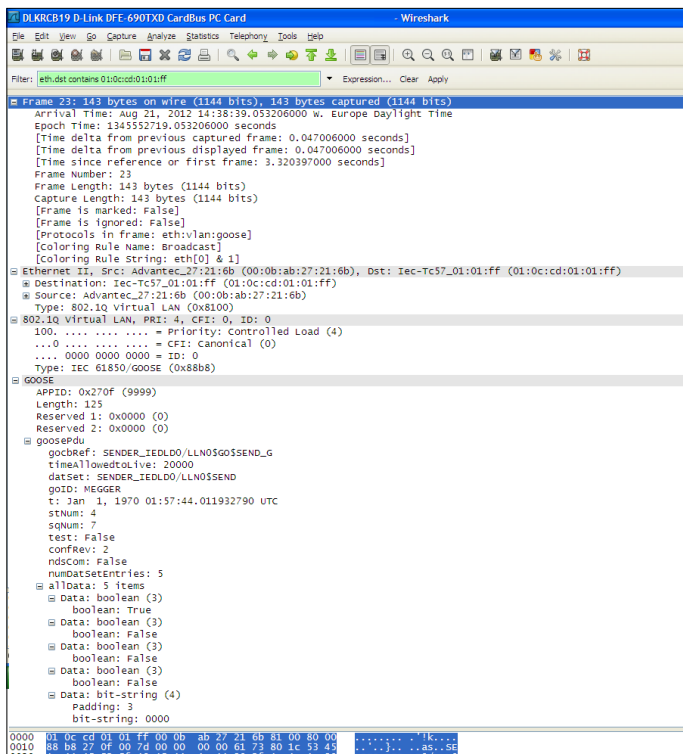

To solve the interoperability problem, we need to compare the information above with the information in the SCL file, which is one XML file

And this is what we can find in other parts of the file:

```

</Substation>
- <Communication>
- <SubNetwork name="Subnetwork" type="8-MMS">
- <ConnectedAP iedName="SENDER_IED" apName="S1">
- <Address>
  <P type="OSI-AP-Qualifier">23</P>
  <P type="IP">10.1.150.3</P>
  <P type="OSI-SSEL">0001</P>
  <P type="OSI-PSEL">00000001</P>
  <P type="OSI-TSEL">0001</P>
  <P type="OSI-AE-Title">1,3,9999,23</P>
</Address>
- <GSE desc="TEST SEND" IdInst="LD0" cbName="SEND_G">
- <Address>
  <P type="MAC-Address">01-0C-CD-01-01-FF</P>
  <P type="APPID">01FF</P>
  <P type="VLAN-PRIORITY">4</P>
  <P type="VLAN-ID">000</P>
</Address>
  <MinTime unit="s">4</MinTime>
  <MaxTime unit="s">5000</MaxTime>
</GSE>
</ConnectedAP>
  
```

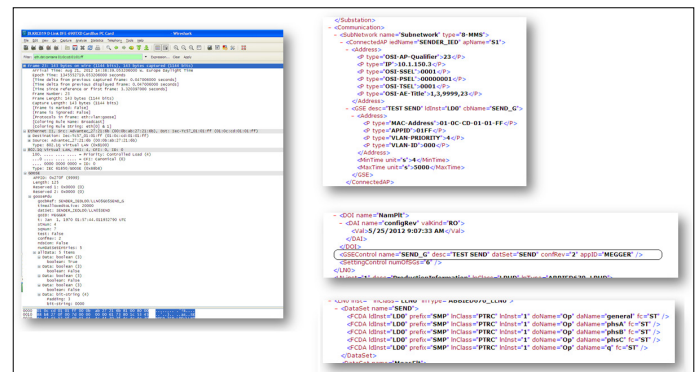

So, comparing raw data is not an intuitive and easy action. A comparison can be done manually and has been done in the past, but the probability to introduce human errors in this work is large, and this operation is very time consuming.

That's why new tools dedicated to the application and more disconnected from raw data protocol are necessary.

What about VLAN?

The Megger GOOSE Configurator software has dedicated a special setting for the MERGE algorithm to handle the VLAN tag. It is possible to use the VLAN tag to discriminate between two different GOOSE messages, or ignore the data in the VLAN tag (different or missing).

IEC 61850 GOOSE Interoperability

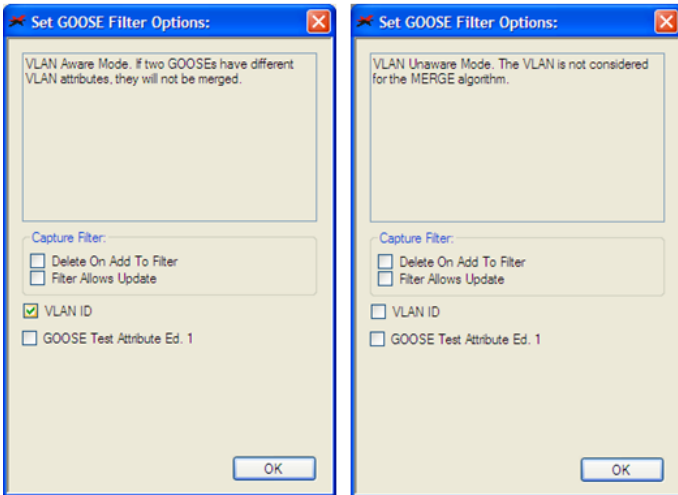

It is recommended to have the VLAN set as “VLAN Aware Mode” in order to enable the strictest possible MERGE algorithm. If two GOOSE messages are not merged (SCL GOOSE and scanned GOOSE), and the only difference is in the VLAN, it is possible that there is an interoperability problem caused by different treatment of the VLAN tag by the receiving IED.

The VLAN tag has created a lot of interoperability problems over the years. Fortunately, Megger’s MERGE algorithm solves the problem there, as well as in the representation of the GOOSE messages during the sniffing (capturing).

VLAN care in the Megger GOOSE Configurator sniffer

If a GOOSE message appears without the VLAN tag, Megger GOOSE Configurator shows the information “Not Found,” warning the user that there could be problems with that particular GOOSE message:

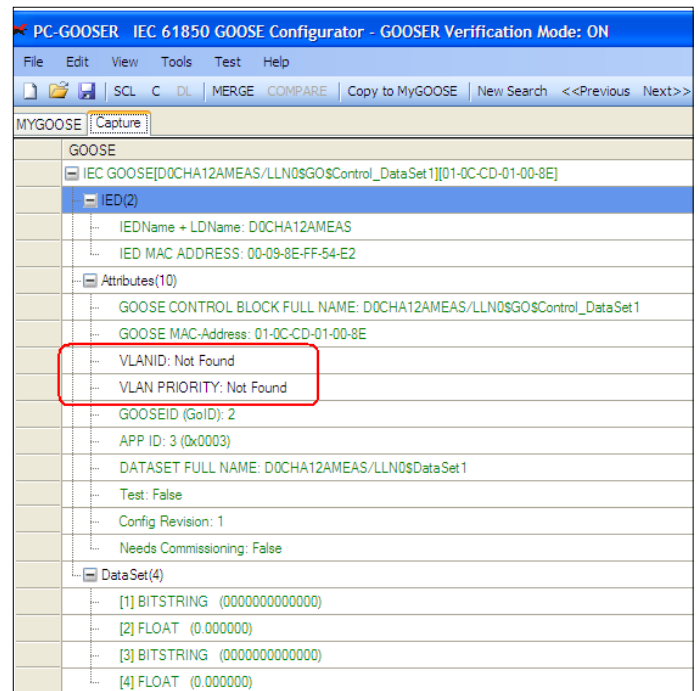

Is your PC dropping the VLAN tag of GOOSE messages?

If a GOOSE message is received by the Megger relay test set with VLAN, but on the PC screen (Megger GOOSE Configurator) it appears without VLAN, it is possible that the VLAN tag is removed by the PC Ethernet card. In this case Megger GOOSE Configurator is able to give this important warning to the user:

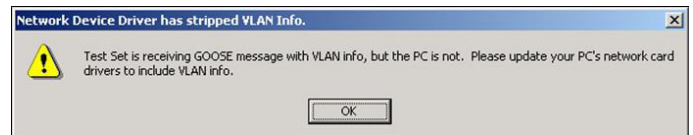

There is a special algorithm and protocol implemented between GOOSER and PC-GOOSER in order to be able to give this important information to the user.

The best solution to this problem, instead of updating the firmware of the Ethernet card installed on the PC, is to install an additional Ethernet card (PCMCIA or equivalent). Experience has shown that those cards usually do not drop (remove) the VLAN tags from the incoming GOOSE messages.

IEC 61850 GOOSE Interoperability

Temporary solutions for interoperability problems

When an interoperability problem occurs in a substation, it is usually known that its solution may require some time, and a lot of commissioning tests are potentially stopped until the problem is fixed. In the conventional technology, there are some temporary solutions to allow the equipment to communicate in order to be able to continue to perform the other tests, before the correct and final solution is done. The IEC 61850 numerical technology requires the use of some new methods and tools to achieve the same result.

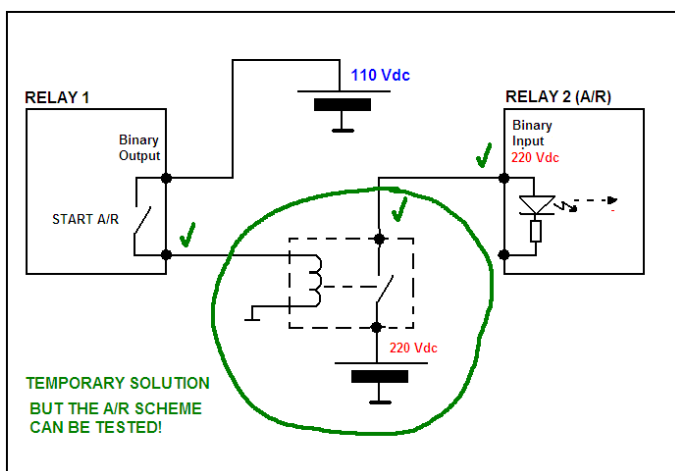

By doing this conversion, which simply requires one auxiliary relay and one power supply at 220 Vdc, the protection scheme between the two relays can be tested and the commissioning of the substation does not suffer unnecessary delays.

Conclusion

As noted in the executive summary, interoperability facilitates valuable business connections — across processes, between people and information, and among companies. Interoperability yields improved collaboration and, ultimately, increased productivity. Providing interoperability helps customers decrease complexity and better manage heterogeneous environments — while enhancing choice and innovation in the market. Interoperability problems can occur in multi-vendor but also in single-vendor applications, however, even with GOOSE messaging. Depending on the firmware of the IED, For example, some IEDs may receive the message with altered VLAN tag and others may refuse it. The simplest solution to this problem is to set the substation switches in such a way that the VLAN tags are not removed nor modified.

Some interoperability problems are due to different interpretations from different vendors of the default values that must be given to the different attributes of the GOOSE message when information is missing in the SCL file describing it. This interoperability problem has been seen in multi-vendor applications. The best method to avoid this problem is to always set all the possible attributes when defining the GOOSE message from the IEC 61850 Engineering tool, and to not leave any field empty.

Other problems discussed in this application note include interoperability issues created by different interpretation of SCL (xml) information (file importing/exporting) and problems created by variances in the IEC 61850 engineering process.

While detecting these issues can be done manually, as described above, the probability of introducing human errors in this work is large, and this operation is very time consuming.

That's why new tools dedicated to the application that are more disconnected from raw data protocol are necessary.

These issues and problems are easily addressed with Megger's MERGE and COMPARE algorithm that is able to identify all the differences between GOOSE messages available on the network and GOOSE messages described in SCL files. This method is more formally known as a GOOSE Consistency Check. This is readily available in the Megger GOOSE Configurator.

IEC 61850 GOOSE Interoperability

Megger offers a large family of products related to this topic, including its SMRT family.

A short summary of products is presented here. For a more complete selection, visit the website at www.megger.com or call 1-800-723-2861.

SMRT 1 Single Phase Relay Test System

- Small, rugged, lightweight and powerful
- Operate with or without a computer
- Intuitive manual operation with Smart Touch View Interface
- High current, high power (75 amps/400 VA rms)
- Network interface provides IEC 61850 test capabilities



SMRT 1 Single Phase Relay Test System

- Handheld controller for SMRT, MPRT sets
- New, more powerful and easier to use click-on-fault Impedance relay test screen
- Large high resolution Color TFT LCD touch-screen intuitive smart navigation makes testing relays easier
- Designed for either right- or left-handed operation with control knob centrally located
- Automatic ramp, pulse ramp and pulse Ramp binary search capability for pick up and dropout tests

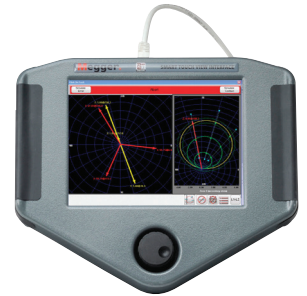

SMRT 46 Three Phase Relay Test System

- Small, rugged, lightweight and powerful
- Operate with or without a computer
- Intuitive manual operation with Smart Touch View Interface
- vHigh current, high power output (60 Amps/300 VA rms) per phase
- 4 Voltage channels, 3 Current channels, with convertible voltage channels provides 1 voltage and 6 currents
- Dynamic, Transient and GPS Satellite Synchronized End-to-End Testing Capability
- IEC 61850 Testing Capability



FREJA 546 Relay Test System

- Fully automated testing using FREJA Win software
- Stand-alone operation using intuitive high resolution graphic touchscreen, no PC required to operate
- High current, high power output – up to 60 Amps / 300 VA rms per phase
- 4 Voltage channels, 3 Current channels, with convertible voltage channels provides 1 voltage and 6 currents
- Dynamic GPS Satellite Synchronized End-to-End Testing Capability
- IEC 61850 Testing Capability



SMRT 410 Relay Test System

- Small, rugged, lightweight and powerful
- Operates with or without a computer
- High current, high power output (60 amps/300 VA rms) per phase
- Flexible output design provides up to four-phase voltage, up to ten-phase current
- Network interface provides IEC 61850 test capabilities



FREJA 549 Relay Test System

- Fully automated testing using FREJA Win software
- Stand-alone operation using intuitive high resolution graphic touchscreen, no PC required to operate
- High current, high power output – up to 60 Amps / 300 VA rms per phase
- Provides up to 9 currents for testing transformer and bus differential relay
- Dynamic GPS Satellite Synchronized End-to-End Testing Capability
- IEC 61850 Testing Capability





Megger Limited
Archcliffe Road
Dover CT17 9EN
United Kingdom

www.megger.com

IEC_61850_GOOSE_Interoperability_AN_EN_V01

The word 'Megger' is a registered trademark. Copyright © 2016 updated in 2022.

Megger[®]