

Instruction Manual
for
Transformer Ohmmeter
50 A DC Winding Resistance Test Set

MTO250

Catalog Number MTO250

HIGH-VOLTAGE EQUIPMENT

Read this entire manual before operating the MTO250.

Megger.

Valley Forge Corporate Center
2621 Van Buren Avenue
Norristown, PA 19403-2329
U.S.A.

610-676-8500

www.megger.com

**Transformer Ohmmeter
50A DC Winding Resistance Test Set**

MTO250

Copyright © 2014 by Megger. All rights reserved.

The information presented in this manual is believed to be adequate for the intended use of the product. If the product or its individual instruments are used for purposes other than those specified herein, confirmation of their validity and suitability must be obtained from Megger. Refer to the warranty information below. Specifications are subject to change without notice.

WARRANTY

Products supplied by Megger are warranted against defects in material and workmanship for a period of one year following shipment. Our liability is specifically limited to replacing or repairing, at our option, defective equipment. Equipment returned to the factory for repair must be shipped prepaid and insured. Contact your MEGGER representative for instructions and a return authorization (RA) number. Please indicate all pertinent information, including problem symptoms. Also specify the serial number and the catalog number of the unit. This warranty does not include batteries, lamps or other expendable items, where the original manufacturer's warranty shall apply. We make no other warranty. The warranty is void in the event of abuse (failure to follow recommended operating procedures) or failure by the customer to perform specific maintenance as indicated in this manual.

Megger.

Valley Forge Corporate Center
2621 Van Buren Ave
Norristown, PA 19403-2329

610-676-8500 (Telephone)
610-676-8610 (Fax)

www.megger.com

Table of Contents

1 MTO250 General Information	1
Product Overview	1
Top Panel Controls	2
2 Safety	7
Operator Responsibility.....	7
General Safety Precautions	7
Input Power Precautions.....	8
3 Specifications	11
4 Parts List and Optional Accessories	13
5 General Operating Procedures	15
Site Preparation.....	16
Making Connections to Specimen	16
Initial Testing	18
Common Test Procedure.....	18
Discharging a Transformer	19
Demagnetization Function	20
Using (Optional) Remote Switch.....	21
Stored Data Functions – Display/Delete/Download	22
Set Time Function.....	23
Set Time and Date Format	23
6 Transformer Testing	25
Testing a Single-Phase Transformer.....	25
Testing a Three-Phase Transformer.....	29
Demagnetizing a Transformer.....	31
Temperature Correction.....	32
7 MTO250 Series PowerDB Lite	33
Introduction	33
Using PowerDB Lite.....	33
Recommended Procedure for Data Storage & Download with Multiple Tap Transformer	37
8 Service	39
Maintenance	39
Calibration	39
Repairs.....	39
Error Codes.....	40

List of Figures

MTO250 Transformer Ohmmeter Test Set.....	iii
Figure 1: MTO250 Front Panel.....	2
Figure 2: Single Winding Measurement.....	25
Figure 3: Dual-Winding Test	27
Figure 4: Reading obtained is one phase per test, Resistance of H1-H0 Winding	29
Figure 5: Reading obtained is between pairs of terminals, resistance $V = H1-H0$ winding and resistance $V2 = H3-H0$ winding (H2 terminal is used to obtain H0 measurement point).....	30

Upon Receipt of Product

Prior to operation, check for loosened hardware or damage incurred during transit. If these conditions are found, a safety hazard is possible, DO NOT attempt to operate equipment. Please contact Megger as soon as possible.



MTO250 Transformer Ohmmeter Test Set

Megger.

1

MTO250 General Information

Product Overview

The Megger Transformer Ohmmeter (MTO) is a line-operated, field-portable instrument designed specifically to measure the DC resistance of all types of magnetic windings safely and accurately. The MTO250 is also capable of testing non inductive low resistance objects such as breaker contacts, high current connections etc.

The MTO250's primary value is the measurement of the DC resistance of highly inductive transformer windings within the defined ranges of current and resistance. The MTO250 will also test rotating machine windings, shunt reactors and perform low-current resistance measurements on connections, contacts and control circuits.

Top Panel Controls



Figure 1: MTO250 Front Panel



Input AC Power Module:

This module is an IEC320 interface to the mains power. The module has an integrated switch and input filter module. The green light on the bottom of the module illuminates when power is ON.

The power input is acceptable from 85 to 264 volts from either a regulated line input or from a suitable stable source portable generator, where frequency must be between 47 and 63 hertz. Please be aware that at voltages below 120V, a potential for inadvertent tripping of the breaker does exist (under maximum load), although the MTO250 is self-protected.

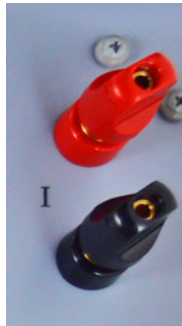

Output Current Connector

This connector is used to connect to the transformer winding(s) and pass the DC power into the transformer winding for testing and demagnetization. The connection is capable of supplying 50 V dc and 50 A dc current. Connection is made via spade lugs on current test leads.



Input Voltage V1

These connections are used to connect a transformer winding for input voltage measurement. The instrument will automatically calculate the resistance of this input in combination with the current source. The connectors are also used as a path for current to flow during discharges. For maximum safety, voltage leads shall always be used in conjunction with current leads.

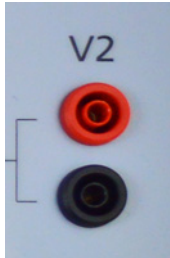

Input Voltage V2

These connections are used to connect a second transformer winding for input voltage measurement. The instrument will automatically calculate the resistance of this input in combination with the current source. The connectors are also used as a path for current to flow during discharges. For maximum safety, voltage leads shall always be used in conjunction with current leads. This measurement can be turned off by depressing the ► key located on the left side of the front panel, but only prior to commencing a test.



Earth/Ground Lug

This connection is used to connect a transformer under test to earth ground for safety purposes and improving measurements while testing in high voltage/high electrical noise stations. The transformer and the MTO shall be at the power ground/earth potential when being operated.



Emergency Shut Down Switch

This switch, when pushed will disable the source power supply and automatically discharge the transformer.



Current Set Switch

This switch is used to control the test current applied to a transformer. Resistance readings remain accurate even when set test current is not reached, so long as a minimum 25% current setting is reached.

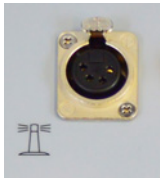

HV Strobe Connector

When the optional HV Strobe is attached to the connector, the user will have a more visible indication of the activation mode of the MTO.



Break Before Make INDICATOR

Blinking Lamp: If test current reduces >10% for a period exceeding "transition time sensitivity setting (set from $\Omega 2$ display). **Solid LED:** Indicates a 200msec hard limit was detected and unit automatically shuts down test current.

Depress  to continue when this condition is reached.

Megger.

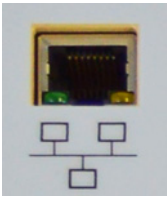

Ethernet Interface

This interface enables data download and MTO250 computer control (via PowerDB). This is also used to perform firmware upgrades.



Remote Control Switch

This connector is used to interface with an optional remote switch. This switch is primarily used for testing Load Tap Changer (LTC/OLTC) of a transformer.

The Remote Control Switch will remotely start the MTO test and store multiple resistance readings while making tap changes (LTC/OLTC type only). The storage function in remote mode is sequential and notes to the operator each stored value's record number. The unit also stores make-break transition events with each resistance. Details of procedure are available below.

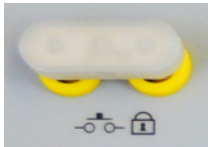

Safety Interlock Connector

These connections are used when there is requirement for additional safety while testing a transformer.

Data Output Mode Switch



MTO is in "Test Mode"



MTO is in "Data Review Mode"



MTO is in "Set Date/Time Mode"



MTO is in "Date Format Mode"

MORE DETAIL IS AVAILABLE ON DATA OUTPUT SWITCH OPERATION in *Section 5 - General Operating Procedures – Common Test Procedure.*

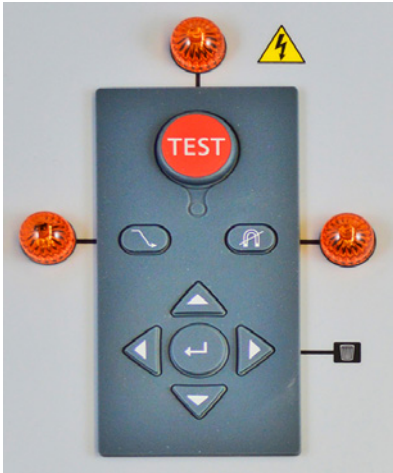

The TEST LAMP stays illuminated while current is flowing, whether in “test mode”, “demagnetization mode” or “current discharge” mode. This lamp is intended as a safety indicator which when lit indicates **Do Not Remove Test Leads**.



TEST BUTTON – When depressed, the MTO will start current flow to the object under test. When depressed while current is flowing, current will begin a discharge routine and the last resistance results will remain briefly on the $\Omega 1$ and $\Omega 2$ display.

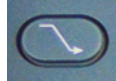

When depressed, will start the current discharge process.



When depressed, will perform a transformer demagnetization. The DEMAG LAMP to the right will illuminate during the demagnetization cycle.



When depressed, the unit will acknowledge data entered (if testing), display additional information (in review), or confirm data deletion actions.

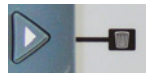

This symbol highlights that the **▶X1** enables the user to DELETE the last recorded result in memory (press **◀** to confirm action). **▶X2**, enables the user to delete all results in a group (press **◀** to confirm action). **▶X3** takes it out of the DELETE state.

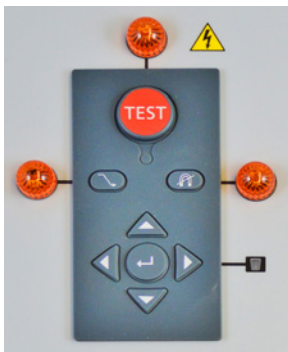

Current Display

This 6 digit display provides operator indication of test current level (provides 4 digits of resolution). When reviewing saved results, this display indicates recorded current and 'Group-Result'.



$\Omega 1$ Display

This display provides operator indication of various parameters. Prior to test initiation, displays “temperature” setting for result storage, and is changed via **▲/▼** arrows. Once **TEST** is depressed, resistance value of V1 is displayed.

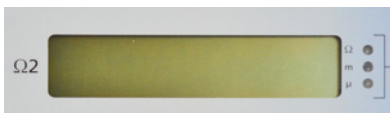

$\Omega 2$ Display

This display provides operator indication of various parameters. Prior to test initiation, displays LTC make/break sensitivity setting as well as $\Omega 2$ ON or OFF setting. LTC sensitivity is changed via **◀** arrow and $\Omega 2$ ON or OFF is changed via **▶** arrows. Once **TEST** is depressed, resistance value of V2 is displayed - if enabled.

Megger.

2

Safety

Operator Responsibility

Only qualified and trained operators should operate the MTO250 system. Operator must read and understand this entire Instruction Manual prior to operating the equipment. Operator must follow the instructions of this Instruction Manual and attend the equipment while the equipment is in use. In the event of equipment malfunction, the unit should immediately be de-energized and returned to Megger for repair.

“The Safety precautions herein are not intended to replace your Company’s Safety Procedures. Refer to e.g. *IEEE 62-1995/IEEE C57.152*, or IEC standards for additional information.



WARNING

When applying current to a transformer with very high inductance, additional care should be taken not to remove current or voltage leads while current is still flowing. This causes an extremely high voltage to develop across the point where current is broken. Under certain conditions, this voltage could prove to be lethal.



WARNING

It is critical to connect leads securely to the bushings of transformers. Ensure that no strain is placed by leads while connected, so as to minimize the risk of inadvertent disconnection.

General Safety Precautions

The MTO and the Unit Under Test (UUT) should both be considered as sources of *instantaneously lethal levels* of electrical energy. Observe the following safety precautions:

- Observe all safety warnings on the equipment. They identify areas of immediate hazard that could result in injury or death.
- Use this equipment only for the purposes described in this manual. Observe strictly the Warning and Caution information provided in this manual.

- Treat all terminals of high-voltage power equipment systems as potential electric shock hazards. Use all practical safety precautions to prevent contact with energized parts of the equipment and related circuits.
- Use suitable barriers, barricades and/or warnings to keep persons not directly involved with the work away from test activities.
- Never connect the test equipment to energized equipment.
- Do not use in an explosive atmosphere.
- Use the grounding and connection procedures recommended in this manual. Always disconnect test leads from power equipment before attempting to disconnect them at the test set. The ground connection **MUST** be the first made and removed last. Any interruption of the grounding connection can create an electrical shock hazard.
- Personnel climbing higher than 5 feet (1.5 m) should follow proper tie off safety requirements.
- Personnel should use proper safety gear to prevent bodily harm.
- Personnel using heart pacemakers should obtain expert advice on the possible risks before operating this equipment or being close to the equipment during operation.



WARNING

No user serviceable parts inside! Refer all servicing to the factory or a qualified authorized service company!



CAUTION

**Use only factory supplied mains cord!
Mains cord shall not be substituted!**

Input Power Precautions

This instrument operates from a single-phase, sine wave, power source. It has a three-wire power cord and requires a two-pole, three-terminal (live, neutral, and ground) type input source. The voltage to ground from the live pole of the power source must be within the following rated operating voltage:

For Catalog No. MTO250: 85 - 264 V, single-phase sine, 47-62 Hz >20%THD

The neutral pole must be at ground potential. Before making connection to the power source, determine that the instrument rating matches the voltage of the

power source. The power input plug must be inserted only into a mating receptacle with a ground contact.



WARNING

Do not bypass the grounding connection. Any interruption of the grounding connection can create an electric shock hazard. Determine that the receptacle is properly wired before inserting power plug into the MTO250.

The control circuits of the instrument are protected by a circuit breaker which also acts as an on/off switch. Therefore, no fuses exist in the MTO250. The circuit breaker is rated at 15A and is fast tripping style. It also acts as an on-off switch for the MTO250.

Megger.

3

Specifications

INPUT	85 – 264 V 47 – 63 Hz >20%THD 1500VA
OUTPUT	
User Selectable Current Ranges:	1 A dc 10 A dc 25 A dc 50 A dc
Test Voltage:	50 V dc
RESISTANCE MEASUREMENT/DISPLAY	
Resistance:	@ 50A 10 $\mu\Omega$ to 40m Ω - auto ranging @ 50A 40 m Ω to 400m Ω auto ranging @ 25A 10 $\mu\Omega$ to 80m Ω - auto ranging @ 25A 80 m Ω to 800m Ω - auto ranging @ 10A 100 $\mu\Omega$ to 200m Ω - auto ranging @ 10A 200m Ω to 2 Ω - auto ranging @ 1A 1m Ω - 2 Ω - auto ranging @ 1A 2 Ω - 20 Ω - auto ranging
For resistance above 20Ω, test current will reduce (@ 1A setting) and readings up to 1000Ω can be measured with accuracy +/- 5% rdg.	
Accuracy:	$\pm 0.25\%$ reading, $\pm 0.25\%$ full scale
Resolution:	4 digits
Displays	Two 1" high, 6 character, 7-segment, LCDs One 0.71" high, 6 character, 7-segment, LCD
USER INTERFACE	B&W numeric displays, keypad
COMPUTER INTERFACE	Via Ethernet port
INTERNAL DATA STORAGE	9 groups (1-9) of results with 99 sets of results per group

SAFETY AND STANDARDS

Conforms to the emissions requirements of EN 61326-1:2006; Clause 7.2:

CISPR11 Edition 4:2003 Conducted Emissions, Group 1 Class A

CISPR11 Edition 4:2003 Radiated Emissions, Group 1 Class A

IEC 61000-3-2:2000 Harmonics

IEC 61000-3-3:2002 Flicker

Conforms to the immunity requirements of EN 61326-1:2006; Table 1:

IEC61000-4-2:2001 Electrostatic Discharge

IEC61000-4-3:2002 Radiated Immunity

IEC61000-4-4:2004 EFT/Burst, Power Ports and I/O Ports

IEC61000-4-5:2001 Surge Immunity, Power Ports

IEC61000-4-6:2003 Conducted Immunity, Power Ports and I/O Ports

IEC61000-4-8:1993, A1:2000 Power Frequency Magnetic Fields

IEC61000-4-11:2004 Voltage Dips and Interrupts

ENVIRONMENTAL

Operating: 14° F to 122° F (-10° C to 50° C)

Storage: -13° F to 158° F (-25° C to +70° C)

Relative Humidity: 0-90% non-condensing

DIMENSIONS

8.5 H x 21.5 W x 13 D
(216 H x 546 W x 330 D mm)

WEIGHT

Net 30 lb (13.6 kg)

4

Parts List and Optional Accessories

Item	Cat. No.
Transformer Ohmmeter 120/230 volt, 50/60 Hz input	MTO250
<u>INCLUDED ACCESSORIES</u>	
Ground lead, 15 ft (4.6 m)	4702-7
AC power cord (IEC60320-C13 to US standard)	17032-23
AC power cord (IEC60320-C13 to Schuko CEE 7/7) AC power cord (IEC60320-C13 to US standard)	17032-19
In-lid Quick Start Guide	4702-7
Canvas carrying bag (for leadsets)	2005-265
Instruction manual	ATVMMTO250
PowerDB LITE software version	DB0001
<u>OPTIONAL ACCESSORIES</u>	
150KV Lead Set 30ft (9 m) c/w:	1004-640
30 ft (9 m) current Lead set Cat# 2000-787-30	
V1 30 ft (9 m) potential lead set Cat# 2000-700-30	
V2 30 ft (9 m) potential lead set Cat# 2000-701-30	
15 ft (4.5 m) current shorting lead Cat# 2000-788-15	
500KV Lead Set 60ft (18 m) c/w:	1004-641
60 ft (18 m) current Lead set Cat# 2000-787-60	
V1 60 ft (18 m) potential lead set Cat # 2000-700-60	
V2 60 ft (18 m) potential lead set Cat # 2000-701-60	
30 ft (9 m) current shorting lead Cat# 2000-788-30	
750KV Lead Set 100ft (30 m) c/w:	1004-642
100 ft (30 m) current Lead set, Cat# 2000-787-100	
V1 100 ft (30 m) potential lead set, Cat# 2000-700-100	
V2 100 ft (30 m) potential lead set, Cat# 2000-701-100	
50 ft (15 m) current shorting lead, Cat# 2000-788-50	
Universal Kelvin lead set, c/w current & potential leads, 30 ft (9 m)	2000-789-30
Universal Kelvin lead set, c/w current & potential leads, 60 ft (18 m)	2000-789-60
Universal Kelvin lead set, c/w current & potential leads, 100 ft (30 m)	2000-789-100
Hard sided transit case, c/w foam lining, for instrument and leads.	2005-258
HV Strobe (Beacon) c/w 60 ft lead (18 m)	1004-639
Remote Hand Switch c/w 60 ft (18 m) lead	30915-220

Megger.

5

General Operating Procedures

When testing high-voltage transformers, caution must be used at all times and all safety precautions followed. Read, understand, and employ all safety precautions and circuit connections described in *Section 2 - Safety*.



WARNING

Ensure that the transformer to be tested is completely de-energized. Check every winding. Ensure that all terminals of the transformer are disconnected from line or load at the transformer. Connections to ground may be left in place.





WARNING

For all testing as described herein, care shall be taken to ensure any and all unused clamps shall be isolated from each other, from ground, and from personnel.

EMERGENCY SHUTDOWN PROCEDURE

There are 4 methods to shut down test current to the MTO250. They are:



- Press red EMERGENCY TEST OFF push button 
- Depress the test button 
- Depress the discharge button 
- Turn the power button to OFF (O).

All actions above place the unit into “discharge mode”. Please note, discharge lamp will only stay illuminated for a brief time with small specimens.

Site Preparation

Choose a location that meets the following conditions:

- The location is as dry as possible.
- There is no flammable material stored in the vicinity.
- The test area is adequately ventilated.
- Be sure all equipment is de-energized and all terminals of the Unit Under Test (UUT) are accessible. Erect suitable safety barriers to protect the operator from traffic hazards and to prevent intrusion by unauthorized personnel. User provided Warning lights are recommended.
- Verify that the Local station ground is intact and has impedance continuity to earth.

Making Connections to Specimen

Connections should be made in the order as listed below.

1. **Ground.** Use the Megger supplied safety ground cable (15 ft (4.6 m)) to connect the MTO ground terminal directly to local station earth ground. Input power source ground terminal should be less than 100 m Ω of impedance to local station earth ground.
2. **Connect the Input Power Cord.** Before making this connection, insure the *Input Power Source* meets the requirements as listed in *Section 2 - Safety* and *Section 3 - Specifications*. Also ensure the ON(|)/OFF(O) switch (*Figure 1*) is in the OFF(O) position. Connect the input power cable to the MTO first, then to the power source.
3. **Connect the Ethernet Cable (optional).** If the user chooses to use a computer, using PowerDB Lite computer software, then connect the Ethernet cable between the MTO and the computer at this time.
4. **Connect the Remote Control Switch (optional).** If the user chooses to operate the *Test Button*  of the MTO from a remote distance, then connect the RCC cable at this time.
5. **Connect HV Strobe (optional).** Connect the HV Strobe cable at this time and place the beacon in a conspicuous location. Typically, one connects this HV strobe to an opposite side of the transformer using the magnetic portion of the HV strobe at a height suitable for individuals within the area to see it easily.

6. **Connect Interlock Switch (customer provided)** The MTO has an external interlock switch feature. Connect the external Interlock Switch via banana jack connection to the interlock input jacks on the front panel. The interlock switch function is a fail open, therefore if not used, an interlock jumper must be placed in the jacks. If the circuit is open IntLoc will be displayed at the middle LCD.
7. **Connect current and potential leads (to the MTO end only at this time).** With the clamps disconnected from the UUT, connect the I and V cables to the MTO. Ensure all plugs are fastened securely to the MTO. Refer to Application *Section 5 - Transformer Testing* for specific conditions such as dual resistance, optimize saturation testing, etc.
8. **Connecting to the Transformer.** When testing high-voltage transformers, caution must be used at all times and all safety precautions followed. Read, understand, and employ all safety precautions and circuit connections described in *Section 2 - Safety*.

WARNING



Ensure that the transformer to be tested is completely de-energized. Check every winding. Ensure that all terminals of the transformer are disconnected from line or load at the transformer. Connections to ground may be left in place.

WARNING



For all testing as described herein, care shall be taken to ensure any and all unused clamps shall be isolated from each other, from ground, and from personnel.

Initial Testing

Once all the precautions and steps of *Section 2 - Safety* are complete, and the connections to the Unit Under Test (UUT) have been made, operator may switch ON (|) the MTO250. See below:

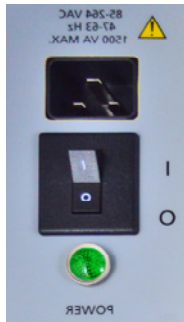

| , ON position
O, OFF position

On power up, an audible beep should be heard, and the MTO250 will perform a self-test check, validating hardware and internal firmware is properly operating.

If an error code is displayed that is uncorrectable, return the instrument to Megger or an authorized service center for repair. Refer to *Section 8 - Service - Maintenance* for a list of error codes. If no errors are detected, the current display will show “ready”.

Common Test Procedure

The user must set the proper test conditions. These are described below:



1. Set the **Function Mode Switch** to TEST  mode. This position is required for current to be initiated.
2. Set the **Current Range Switch** to the desired amplitude. Recommended levels are <15% of rated transformer winding under test.





3. The $\Omega 1$ window will display the temperature value that the unit will store with the resulting data for all subsequent tests. To change temperature setting depress ▲/▼ arrows to the desired value (this will not correct displayed resistance readings).
4. If one is testing LTC/OLTC (Load Tap Changer) positions of a transformer, a time saving method is to maintain energized current while changing tap positions (precautions in *Section 2 – Safety* should be followed). Operator should now set the make/break transition setting as displayed on $\Omega 2$. This setting is



L0 to L4, and is changed via the ◀ arrow. This setting is related to the sensitivity of the LTC/OLTC transition, and typically starts at L1 – 2ms (if used). If tap changer is not in optimum condition or of a poorer design, this setting is changed to L2-L4 (20 – 80ms) transition sensitivity. Set to L0 to disable.

5. Depress  and the unit will apply power to the transformer and charge the winding(s) under test to the maximum current set level. Once the current begins to stabilize, the unit will display resistance readings.
6. For the more highly inductive transformers, proper resistance readings may take additional time. This will be noted by the operator via the resistance display, which slowly falls or rises (example: by one digit per 10-15 seconds).

After a reading is stabilized, depress  to save displayed result (saves resistance, test current, temperature and make/break values for $\Omega 1$ and if ON, $\Omega 2$). Immediately after depressing  the record value for this result will be displayed on the current (I) display.

The  button makes it possible to record multiple readings while current is maintained for load tap changer units on transformers (LTC/OLTC). The MTO250 will toggle the stored test results record number in the current display every 2 seconds.

If a reading is mistakenly saved, the MTO250 has built in safe guards to minimizing this situation. The MTO250 waits 3 seconds before it allows another reading to be recorded. This minimizes accidental double pressing keys when saving results. If a reading is mistakenly taken, depressing ▶, followed by  will delete the last saved record.

7. Pressing  a second time will begin the current discharge of the transformer, briefly displaying the last readings on the display. The discharge indicator will illuminate during the discharge, and turn off when complete. The result will display briefly, but disappear. The instrument returns to 'ready state' until another function or  is selected.

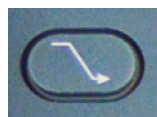

Discharging a Transformer



This button will stop testing and discharge the transformer. The *Discharge Indicator* to the left will illuminate during the discharge cycle.

The MTO discharge circuitry is built-in. It will automatically initiate when the current source is disconnected from the transformer. It will also provide visual indication of discharging via a lamp to the left of the  button.

There are 4 methods where the discharge test circuit in the MTO250 is activated (after test current is flowing). They are:

- Press red EMERGENCY TEST OFF push button .
- Depress the test button .
- Depress discharge button .
- Turn the Power button to OFF (O).

Demagnetization Function



This button will perform a transformer demagnetization. The *Demag Indicator* to the right will illuminate during the demagnetization cycle. In addition, the $\Omega 1$ display will show the progress and the current display will show each current magnitude step by step.

The MTO demagnetizes the transformer by automatically magnetizing the core in the positive and negative direction with multiple cycles of reduced current. During the demagnetization, the unit will display the remaining number of cycles on $\Omega 1$.

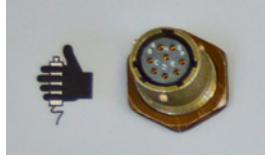

Using (Optional) Remote Switch

1. Connect *Remote Control Switch* (optional accessory) to the remote connector on the front panel of the instrument.







2. Power ON (|) the instrument.

The Unit will detect the remote switch and display 'r n n t 0/1' (rmt 0 or 1) on the $\Omega 1$ display. The '0' is displayed when the switch is open; the '1' is displayed when the switch is depressed. Depressing the remote switch prior to testing confirms proper operation of the remote switch.

3. To start a test sequence, depress  on the front panel. This will NOT begin charging transformer (when remote switch is in the circuit) but will illuminate the HV lamp in a flashing manner. The remote switch built in lamp will begin in the ON state.
4. The operator should now validate that they are on the proper tap position on the transformer LTC (OLTC), and once confirmed, depress the remote switch  to begin the first test.



The remote indicator lamp will slow flash to indicate charging. The MTO250 HV lamp will now illuminate with a steady light to show current is flowing. When the remote indicator lamp becomes solid, the reading is displayed on the MTO250. This does not confirm a steady result, only that the reading is displayed. Different transformers require different stability times and as a rule of practice operator should view the first result value on the instrument and count the time (in seconds) to achieve a desirable steady value. This 'wait time' should be used for each tap position tested.

5. Depressing  the second time will save the result to memory. During this sequential testing, the MTO continues to monitor and save *Make/Break* transition events (as set by operator in $\Omega 2$ display at start of testing).
6. If a 200ms *Make-Break* event occurs, depress  and then remote switch  to continue testing. This will re-activate the test current *and begin* to flash slowly until reading displays on the resistance display. See Step 4. Depress  a second time to continue recording.



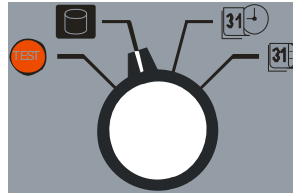









Stored Data Functions – Display/Delete/Download

The MTO can save up to 891 (99 results per group in 9 groups) test results to memory for archival purposes. If data is stored while testing, the unit can step through the memory after testing in a review process.



1. Set the *Data Output Mode Switch* to  (stored results mode). The unit will display the last data stored including the results record number and the data group (1-9). The result record number, group number and time of test will flash on the current (I) display. Depressing  will display detailed results of current and two resistance values. Pressing  will alternate between the two displays.



NOTE: *When the MTO storage is full, the message “StorAg FULL” will be displayed at power up or when reviewing data.*

2. Depress  and  to scroll the stored data within a group. Depress  +  /  simultaneously to change the results 'group' (groups 1-9) to be viewed. Each record will display 'group# - record #' in the right portion of the current (I) display.
3. Depress  to delete the stored data within the group displayed from the unit. The unit will ask for confirmation 'rst' on the $\Omega 1$ screen and 'SURE' on the $\Omega 2$ screen. Press  to confirm deletion.
4. Depressing  a second time will begin a process to delete all stored data within the selected group from the unit. The unit will ask for confirmation 'grp' on the $\Omega 1$ screen and 'SURE' on the $\Omega 2$ screen. Press  to confirm deletion.
5. Depressing  a third time will exit 'delete mode'.
6. **OVERWRITING AN EXISTING RECORD.** – From Steps 1 and 2, select the result to be overwritten. Depress . The $\Omega 1$ display will show 'retest'.
Change switch position  to TEST position. Depress  and follow Steps 1 to 6 as outlined in 'Common Test Procedure', above. This will replace existing record with new results.

Set Time Function

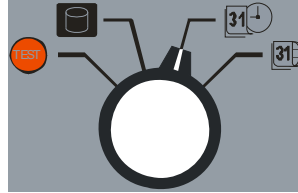
The MTO can set the Time of Day from the front panel interface. Set the function mode switch to the Date Time Setting as shown below.



1. Set the function mode switch (above) to  set time mode. Date will display on MTO250 to show 'year' on current (I) display, 'day/month' on $\Omega 1$ and 'time' on $\Omega 2$ displays.
2. The first time change will be year on current (I) display (last 2 digits will be flashing). Use ▲ and ▼ to change or if correct, depress ◀ and ▶ arrows to navigate to next setting. The active parameter will blink on and off.
3. Use  to confirm change after *each* parameter change.

Set Time and Date Format

The MTO allows change in the Date Format. This will accommodate different international time standards.

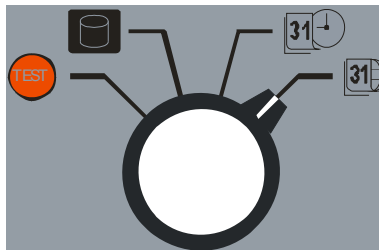

1. Set the Function Mode Switch to Date Format Mode.
2. Depress ▲ or ▼ arrow to select “year/month/day” to “month/day/year” to “day/month/year”.
3. Depress  to confirm any changes made to selected parameters.

Megger.

6

Transformer Testing

Testing a Single-Phase Transformer

Single-Winding Test

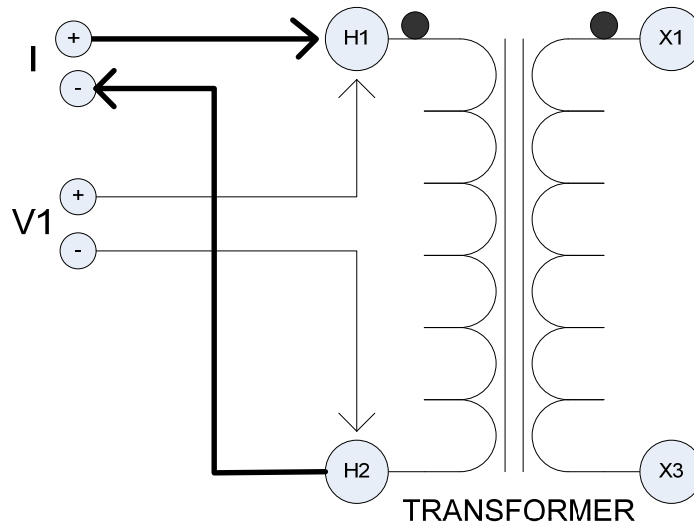

Figure 2: Single Winding Measurement



WARNING

Do not disconnect leads until all indicators are OFF!

PROCEDURE:

1. Connect line cord to unit and plug into a suitable power source. If using a generator, ensure that VA capability exceeds 1500VA and that THD <30%
2. Connect Safety GND cord from Top Panel to Transformer GND.
3. Set the following conditions:

a.

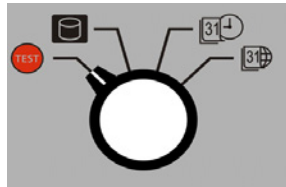



Set to **TEST** position.

b.



Set to desired **MAXIMUM TEST CURRENT**.

4. Connect current leads (I) to test specimen winding. See *Figure 2*.
5. Connect "V1" voltage leads to test specimen winding. **Voltage leads should always be placed inside (between) current leads and the transformer.** Do not place potential leads on the current leads, since this will add contact resistance to the measurement. Turn power switch ON (|).
6. Press  button to initiate current flow.
7. The top smaller display indicates current output and the Ω 1 display indicates resistance of specimen.
8. When measurement is complete, press  to terminate measurement and discharge current. Discharge is complete when the discharge indicator and the test current lamp are off.
9. Remove the current leads from the transformer.
10. Remove the potential leads from the transformer.

Dual-Winding Test

This procedure describes the testing of both windings (high and low) on a single-phase transformer at the same time.

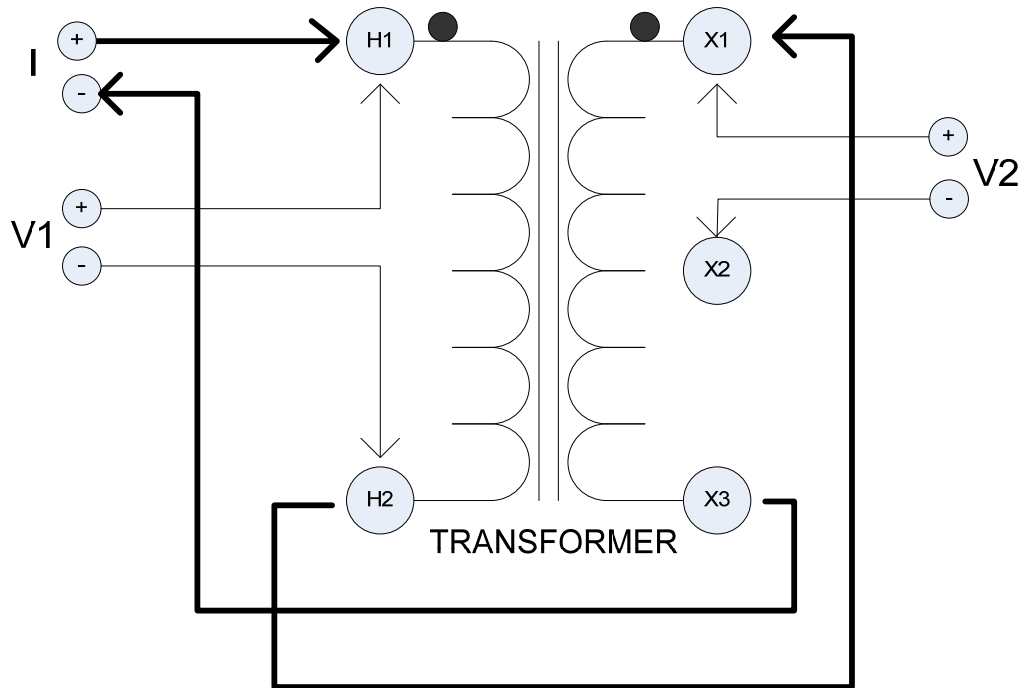

Figure 3: Dual-Winding Test



WARNING

Do not disconnect leads until all indicators are OFF!

PROCEDURE:

1. Connect line cord to unit and plug into a suitable power source. If using a generator, ensure that VA capability exceeds 1500VA
2. Connect Safety GND cord from Top Panel to Transformer GND.
3. Set the following conditions:

a





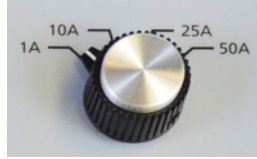

Set to TEST position.

b.



Set to desired MAXIMUM TEST CURRENT.

4. Connect "V1" voltage leads input to H1 and H2 terminals of test transformer. See *Figure 3*.
5. Connect "V2" voltage leads input to X1 and X2 terminals of test transformer. See *Figure 3*.
6. Turn power Switch "ON".
7. Press  to initiate current flow. The top display (I) indicates current output and the $\Omega 1$ display indicates resistance of primary winding and $\Omega 2$ display indicates the resistance of the secondary winding specimen.
8. When measurement is complete, depress  to end the measurement and discharge current or depress  button to record the result followed by  to end measurement. Discharge is complete when discharge and test lamp indicator is OFF – see below.

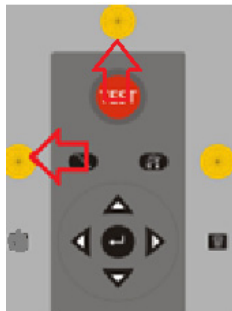

Testing a Three-Phase Transformer

General

The MTO250 has sufficient current to saturate and measure windings quickly, where only minutes per tap are required. It should be noted that with higher test current comes potential issues related to operator/transformer safety and with severe core magnetization. Below is application information related to testing transformers, but can be applied to shunt reactors and motors/generators.

Wye Configured Windings

PROCEDURE:

1. Three-Phase Wye Configured Winding with Neutral

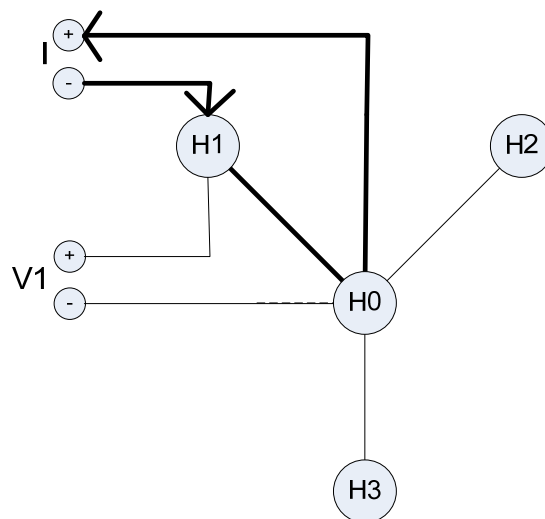

Figure 4: Reading obtained is one phase per test, Resistance of H1-H0 Winding

Use the above diagram in conjunction with procedure *Single-Phase Transformer Test*. Switch both current and potential leads for each phase tested. Always place the potential lead between the current lead and the transformer bushing for best accuracy.

Three-Phase Wye Configured Winding, No Accessible Neutral

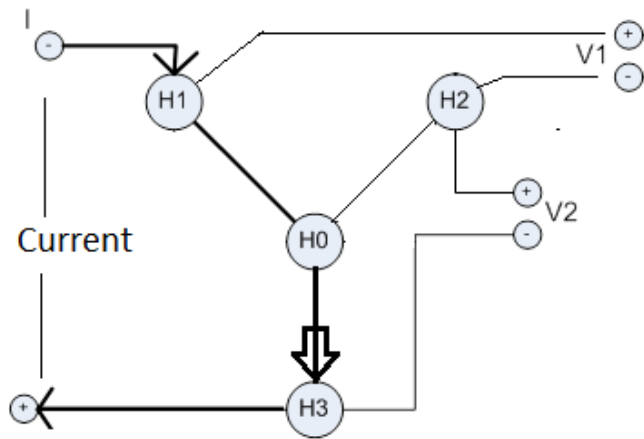

Figure 5: Reading obtained is between pairs of terminals, resistance $V = H1-H0$ winding and resistance $V2 = H3-H0$ winding (H2 terminal is used to obtain H0 measurement point)

Use the above diagram in conjunction with procedure *Dual Winding Transformer Test* above, except no shorting lead is required.

Note: Because H0 connection is inaccessible, the connection to the untested winding is used (H2 for this example) to obtain the H0 potential point. Although not exact, this is the best approximation for readings of phase to neutral windings.

Delta Winding Resistance

Manufacturer's winding resistance data are usually presented as per winding for Y configurations and per terminal pairs for Delta windings. In the rare case that manufacturer's data is presented per winding for a delta connection, the recommendation is to recalculate the numbers to terminal pairs and compare with the field measurement results.

R_{avg} = Average individual winding resistance

R_{tp} = Winding resistance between terminal pairs

$R_{tp} = R_{avg} * 0.6667$

Demagnetizing a Transformer

The MTO demagnetizes the transformer by automatically magnetizing the core in the positive and negative direction with multiple cycles of reduced current. The demagnetization function is equivalent to generating test currents for multiple resistance tests. During the demagnetizations process, the MTO250 will display:

- the number of cycles left in the process in $\Omega 1$ display
- the total demagnetization time on the $\Omega 2$ display
- the demagnetization current applied (-ve and +ve values)
- 'done' is displayed on $\Omega 1$ display once demagnetization is complete.

IMPORTANT POINTS RELATED TO THE DEMAGNETIZATION PROCESS:

1. Demagnetization is only required once after all resistance testing is complete.
2. Demagnetization time varies with inductance of transformer, and demagnetization current chosen. It may be as short as 3 minutes, but as long as 30 minutes.
3. Current and Voltage leads should be attached to one phase/terminal pair on high side (Primary) windings for more effective demagnetization.
4. Ensure voltage leads are attached as discharge energy is absorbed through the voltage leads.
5. For most transformers, it is only required that the middle winding (core) be connected for demagnetization. This is a good reason to save the middle phase as the last winding resistance test performed (saves connection time – more efficient). If demagnetization is not effective with single phase, one can perform demagnetization on all 3 windings of the high side of transformer. With this process, begin with outer phase and end with middle phase for best results.
6. For best demagnetization results, apply the same current as was used for winding resistance test. The MTO250 has an algorithm which calculates correct currents for each step in the demagnetization process.
7. If demagnetization process does not fully demagnetize transformer, operator can perform same demagnetization again (at same current) or increase to next highest current
8. If only low winding tested, one can demagnetize either low or high winding.

9. To validate level of magnetization, use before and after SFRA results or perform before and after excitation testing (for each phase). Any significant difference denotes residual magnetization. For proper demagnetization, difference should be less than 3mA for excitation current (depending on size and construction of transformer)

Temperature Correction

It may be necessary to convert the resistance measurements to values corresponding to the reference temperature in the transformer test report.

Conversion of Resistance Measurements

Winding resistance measurements are normally converted to a standard reference temperature.

The conversions are accomplished by the following formula:

$$R_s = R_m (T_s + T_k) / (T_m + T_k)$$

where

R_s = resistance at desired temperature T_s

R_m = measured resistance

T_s = desired reference temperature

T_m = temperature at which resistance was measured

T_k = 234.5 (copper)

T_k = 225 (aluminum)

7

MTO250 Series PowerDB Lite

Introduction

For more information, or updates to the software, visit www.PowerDB.com.

Minimum Recommended System

- Operating System: Windows 2000 or later
- RAM: 64 MB RAM minimum, 512+ MB RAM recommended
- Processor: 300 MHz Pentium Class processor minimum, 1 GHZ or better recommended

Using PowerDB Lite

1. Instrument Setup Screen

1. Select **MTO-2XX** from the Instrument Setup Screen.

You can always view the Instrument Setup screen from the Tools menu or F3.

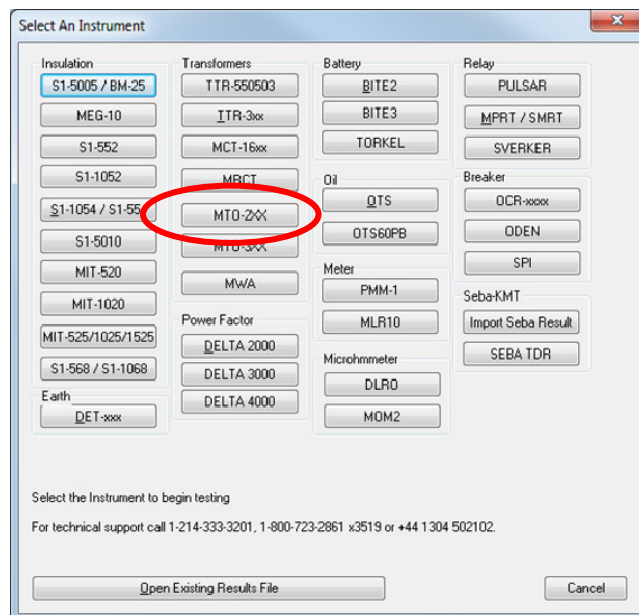

The MTO 250 uses Ethernet communication. This is the default selection and cannot be changed.

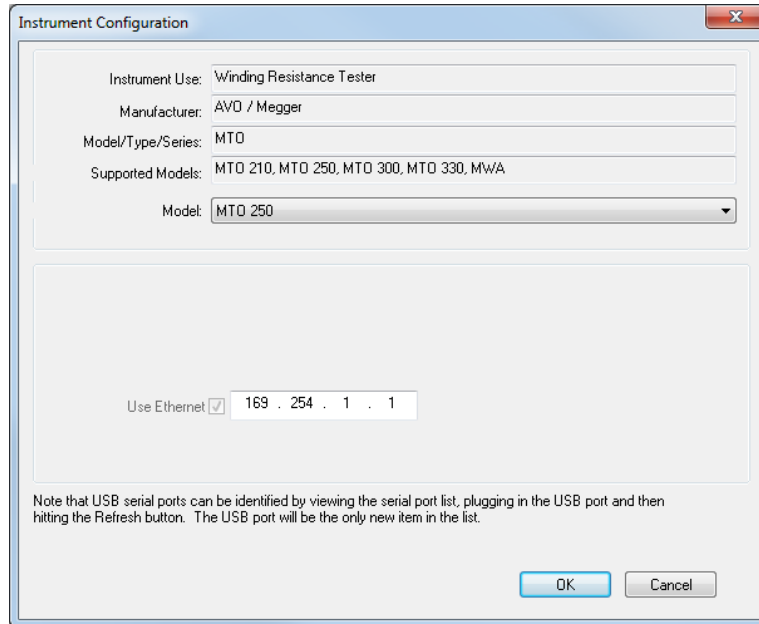

- a. Click **OK** on the Instrument Setup Screen to finish.

2. Fill out the Form

Manually enter Header and Nameplate Information (for 2XX or 3Ø form)

3. Download Test Data (2XX form example)

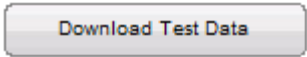
- a. Connect the MTO to your PC via Ethernet cable provided with instrument.
- b. Turn the MTO on.
- c. Wait minimum of 30 seconds, and then click . This action will draw the data from the MTO if connections are properly made. No action is required from MTO to have data sent to computer.

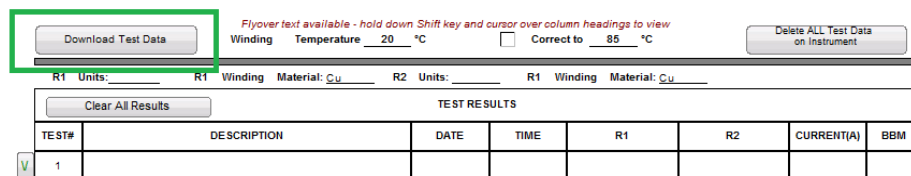

- d. Wait for PowerDB to download all of the data. The form will be populated automatically.

4. Manipulate Test Data

- a. Use the **Correct** to checkbox to change the results from actual readings to temperature corrected readings based off of Winding Temp and Correct To in the Nameplate data

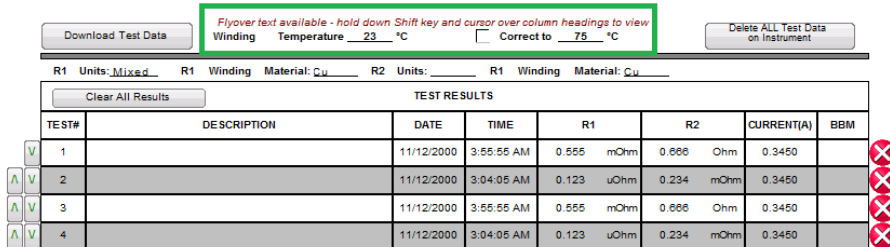

- b. Change the units (Ω , m Ω , u Ω) for each column of resistance data by using the dropdown boxes labeled **R1 Units** & **R2 Units**.

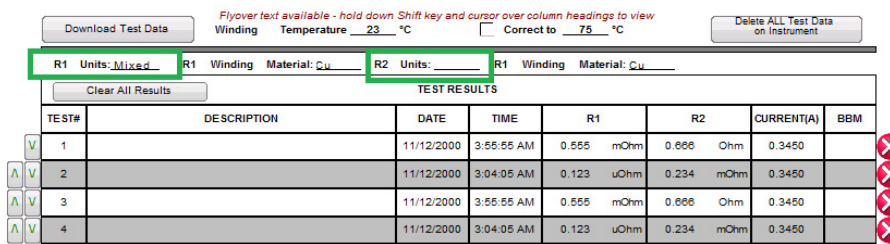

- c. Move test data up/down using the green arrows to the left side of the resistance table data.

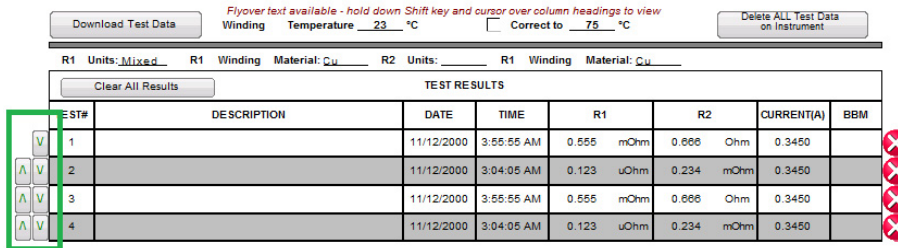

- d. Delete test data by clicking  to the right side of the resistance table data.

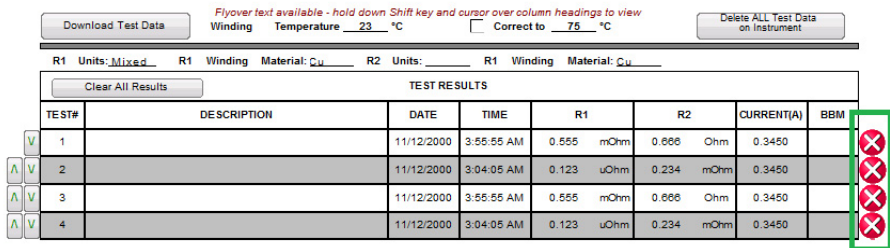

- e. Fill in Comments/Deficiencies, if applicable.

5. Optional: Delete All Test Data On Instrument

Press  to delete all of the test data on instrument.



6. Save The File

- a. Select File -> Save (or CTRL + s)
- b. Manually type in the File name you would like to use.

7. Open Saved Results

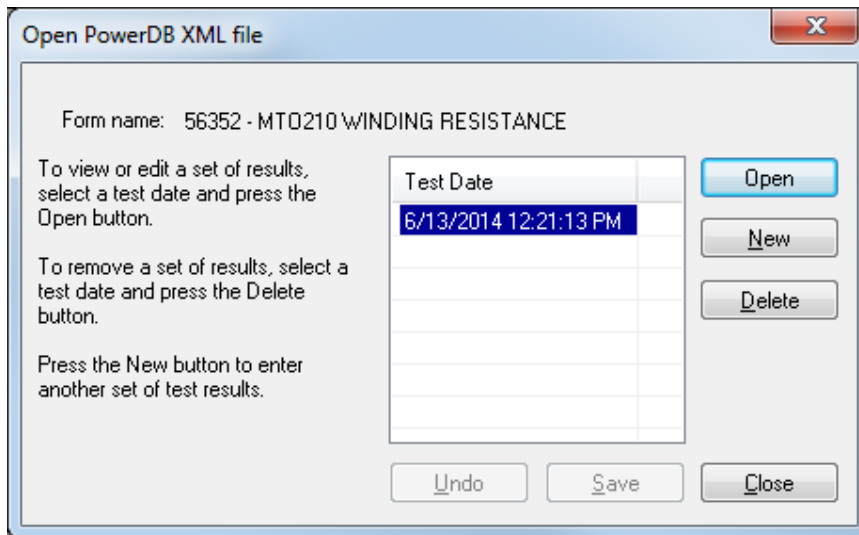
- a. Go to File -> Open (or CTRL + o)
- b. Navigate to your saved file directory and open the file.



- To add results to the file, click . This will create an additional result below original result labeled as a date.
- To view previously saved results, select the test date you want to view and click .
- To delete saved results, select the test date you want to delete and click .

8. SET LANGUAGE/MEASUREMENT/LOGO OPTIONS

- a. Select Tools -> Options...

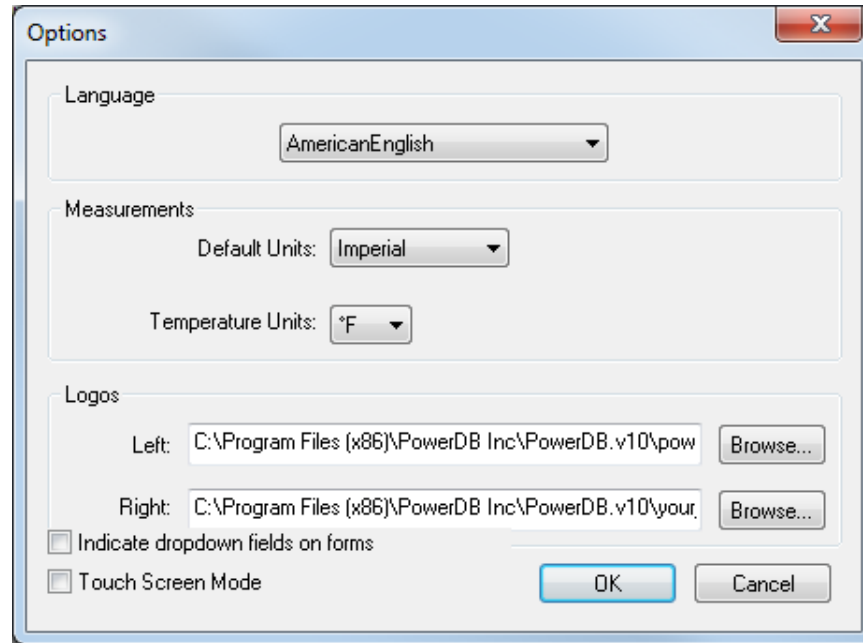

- b. Select the desired language from the dropdown box.
- c. Select the desired *Default Units* and *Temperature Units*.
- d. To change the right/left logo, click the browse button and navigate to the logo you wish to use.

Recommended Procedure for Data Storage & Download with Multiple Tap Transformer

1. Delete all existing test data on instrument (see procedure in *Section 5 - General Operating Procedures - Stored Data Function - Display/Delete/Download*).
2. Connect leads to measure two windings at the same time. See *Table 1-Examples on Transformer Connection Schemes for Injecting Test Current and Measuring Two Windings Simultaneously* as an example of how to connect the leads to take two measurements.
3. Measure the first two windings connected (typically phase A and phase C for balance) in the first Data Group. For LTC tap changers, begin at first tap, record, change tap without de-energizing test current, and continue recording until last tap is measured and recorded.
4. Connect leads to measure the last winding (phase B in this example), change the Data Group to number two, and turn off the R2 measurement.
5. Take measurements as in Step 3 above for R1.

6. Connect the MTO to your PC.
7. Download the test results to the PowerDB using the 3Ø form.

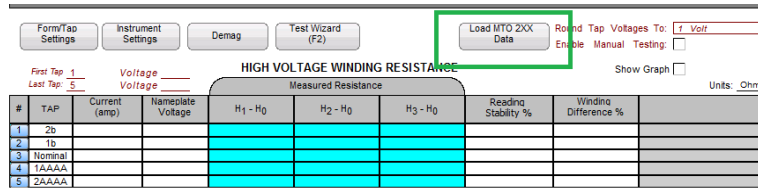

8. Use the options to configure the data import. This includes:
 - a. Selecting Primary/Secondary/Tertiary Winding
 - b. First/Last Tap
 - c. R1/R2 Phases for data
 - d. Group Number

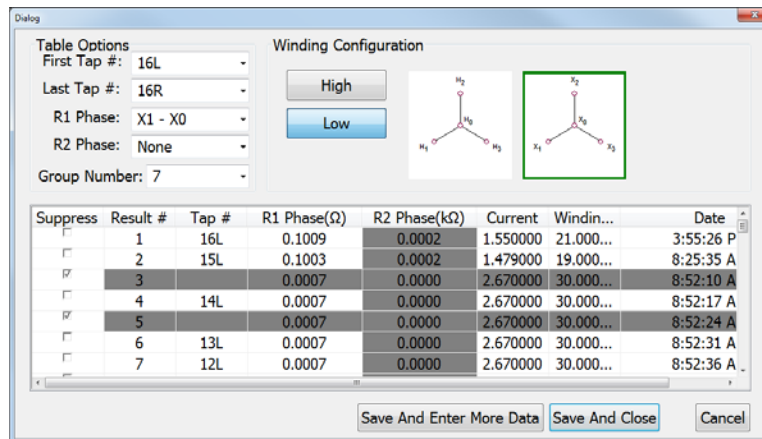

9. Results can be suppressed row by row by clicking the corresponding checkbox. The corresponding Tap# will adjust based on the rows suppressed.
10. Data can also be suppressed by choosing 'none' from the R1/R2 Phase.
11. Click *Save and Enter More Data* if you are entering more than one Phase. Click *Save and Close* when you are done entering data.
12. View the results on the graphs provided on the last page(s).

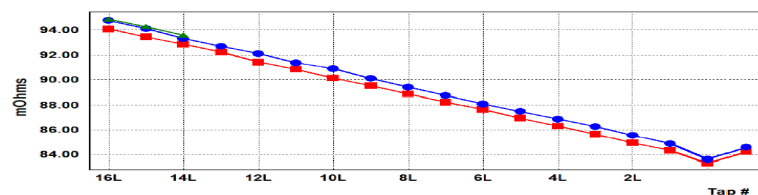

8

Service

Maintenance

Maintenance should be performed only by qualified persons familiar with the hazards involved with high-voltage test equipment. Read and understand *Section 2, Safety*, before performing any service.

Routine maintenance is required for the MTO test set.

The appearance of the MTO test set can be maintained by occasionally cleaning the case, panel and cable assemblies.

1. Clean the outside of the carrying case with detergent and water. Dry with a clean, dry cloth.
2. Clean the control panel with a cloth dampened with detergent and water. Do NOT allow water to penetrate panel holes, because damage to components on the underside may result. An all-purpose, household spray cleaner can be used to clean the panel. Polish with a soft, dry cloth, taking care not to scratch the display screen cover.
3. Clean the cables and mating panel receptacles with isopropyl or denatured alcohol applied with a clean cloth.
4. Inspect the cable assemblies occasionally to ensure they are in good condition.

Calibration

A complete performance and calibration check should be made at least once every year. This will ensure that the MTO test set is functioning and calibrated properly over the entire measurement range. The MTO calibration is performed on each new or repaired unit before sending it to a customer. There is a special MTO final calibration procedure which requires a NIST-traceable test equipment to be used. As a result of such calibration procedure, each MTO test set may be NIST certified.

Repairs

Any service or repair of this equipment should only be performed by qualified persons who are aware of electrical hazards and the necessary precautions required to prevent injury.

Megger offers a complete Repair and Calibration Service and recommends that its customers take advantage of this service for routine maintenance or in the event of any equipment malfunction.

In the event that Service is required, contact your Megger representative for a product Return Authorization (RA) number and shipping instructions.

Ship the product prepaid and insured and marked for the attention of the Megger Repair Department. Please indicate all pertinent information, including catalog number, serial number, and problem symptoms.

Error Codes

The MTO comes with a wide range of error codes to assure unit is working properly and track down problems in a systematic manner. When an error code is observed, the problem may be caused through an internal issue (no possible correction by operator) or through an application error (a correctable situation). The first step once an error is displayed is to acknowledge the error by pressing  and repeating the test or sequence. If the error persists, review the list below *or* as is noted on the *Quick Guide* and determine if cause is correctable. If the error is not found below, please record error number; contact Megger (or an authorized Megger Service Center) for additional assistance. **Bold Error** codes with the possible causes are defined below.

CODE	Error Description	Possible Cause
ESd	ESD is in depressed state	Button is pushed down
IntLoc	Interlock is open	Interlock Jumper removed
1XX	<i>Ethernet and top panel errors (MTO2XX ONLY)</i>	
102	Ethernet communication failed	When connected to PC, check connection to computer
2XX	<i>Initialization errors</i>	
214	EsD – Emergency Off Switch	Emergency Switch closed. Lift to disengage.
243	Discharge circuit -temperature too high. Unit overheated.	Fans not operational, long continuous use, extreme hot test conditions
244	VICOR circuit -temperature too high. Unit overheated.	Fans not operational, long continuous use, extremely hot test conditions
3XX	<i>ADC_ERROR</i>	
4XX	<i>HARDWARE_ERROR</i>	

CODE	Error Description	Possible Cause
411	Current output not insufficient for range selected	Resistance of specimen too high for current range selected, poor current lead connection
468	Received abort signal	Message only with MTO software - test was aborted within the software by user.
471	Current not flowing properly while charging	Current leads not connected properly or problem with specimen
472	Break before make condition	Lead removed during testing. Test specimen LTC has problems. This condition is created when >10% current change during testing.
480	Current = 0	Test enabled, with no current output, check lead connections.
494	ESD Abort signal encountered	Switch pushed down during test

Megger.