

Instruction Manual
for
Transformer Ohmmeter
DC Winding Resistance Test Set

MTO210

Catalog Number MTO210

HIGH-VOLTAGE EQUIPMENT

Read this entire manual before operating.

Megger™

Valley Forge Corporate Center
2621 Van Buren Avenue
Norristown, PA 19403-2329
U.S.A.

610-676-8500

www.megger.com

**Transformer Ohmmeter
DC Winding Resistance Test Set**

MTO210

Copyright© 2011 by Megger. All rights reserved.

The information presented in this manual is believed to be adequate for the intended use of the product. If the product or its individual instruments are used for purposes other than those specified herein, confirmation of their validity and suitability must be obtained from Megger. Refer to the warranty information below. Specifications are subject to change without notice.

WARRANTY

Products supplied by Megger are warranted against defects in material and workmanship for a period of one year following shipment. Our liability is specifically limited to replacing or repairing, at our option, defective equipment. Equipment returned to the factory for repair must be shipped prepaid and insured. Contact your MEGGER representative for instructions and a return authorization (RA) number. Please indicate all pertinent information, including problem symptoms. Also specify the serial number and the catalog number of the unit. This warranty does not include batteries, lamps or other expendable items, where the original manufacturer's warranty shall apply. We make no other warranty. The warranty is void in the event of abuse (failure to follow recommended operating procedures) or failure by the customer to perform specific maintenance as indicated in this manual.

Megger.

Valley Forge Corporate Center
2621 Van Buren Ave
Norristown, PA 19403-2329

610-676-8500 (Telephone)
610-676-8610 (Fax)

www.megger.com

Table of Contents

1	Getting to know the MTO210	1
	Product Overview	1
	Top Panel Controls	3
2	Safety	7
	Safety is the responsibility of the user	7
	General Safety Precautions	8
	Input Power Precautions.....	9
3	Preparing for a Test.....	11
	Site Preparation.....	11
	Making Circuit Connections	11
4	Operating the MTO210.....	15
	Description of Test Sequence	15
5	Transformer Testing	25
	Winding Resistance Testing.....	25
	Testing a Single-Phase Transformer.....	26
	Testing Delta Configured Windings	33
	Testing Transformers with Tap Changers	35
	Testing Voltage Regulators	36
	Demagnetizing a Transformer.....	39
6	MTO210 Series PowerDB Lite	41
	Introduction	41
	Software Installation	42
	Using PowerDB Lite.....	45
	Frequently Asked Questions (FAQ's).....	52
7	Service	53
	Maintenance	53
	Fuse Replacement	53
	Calibration	54
	Repairs.....	55
	ERROR CODES	56
8	Parts List and Optional Accessories	63
9	Specifications.....	65

List of Figures

MTO210 Transformer Ohmmeter Test Set.....	iii
Figure 1: MTO210 Front Panel	3
Figure 2: Single Winding Measurement	26
Figure 3: Dual-Winding Test.....	28
Figure 4: Reading obtained is per phase, Resistance of A-N Winding	31
Figure 5: Reading obtained is between pairs of terminals, Resistance of A and B Windings.....	32
Figure 6: Reading is between pairs of terminals. Resistance of A in parallel with B+C windings.....	32
Figure 7: Odd Position Tap.....	36
Figure 8: Even Position Tap.....	36
Figure 9: Connection to a Regulator	37

Upon Receipt of Product

Prior to operation, check for loosened hardware or damage incurred during transit. If these conditions are found, a safety hazard is likely, DO NOT attempt to operate equipment. Please contact Megger as soon as possible.



MTO210 Transformer Ohmmeter Test Set

Megger.

1

Getting to know the MTO210

Product Overview

The Megger Transformer Ohmmeter is a line-operated, field-portable instrument designed specifically to measure the DC resistance of all types of magnetic windings safely and accurately.

Its predominant use is the measurement of the DC resistance of all types of transformer windings within the defined ranges of current and resistance. It can also test rotating machine windings and perform low-current resistance measurements on connections, contacts and control circuits.

Four features are combined to make this instrument unique: dual measurement and current injection, on-load tap-changer testing, automatic discharge and demagnetization..

The dual set of potential inputs, simultaneously measure the resistance of the primary and secondary windings of a single- or three-phase transformer. The dual reading characteristic will speed up the measurement when current leads are driving more than one winding.

The Transformer Ohmmeter is extremely useful when testing the windings and contact resistance on tap-changers with make-before-break contacts and voltage regulators. A warning light will flash and the internal shutdown circuit will be triggered if the tap-changer contacts have a break before make event. This action checks for pitted or misaligned contacts and indicates such events.

Likewise users are protected by the shutdown circuit safety feature: any inadvertent disconnection of a test lead or loss of power to the instrument will safely and quickly discharge the energy stored within the test sample.

The MTO210 has an added post test feature. At the end of a transformer test, the instrument has a demagnetization function. This function will cycle thru the transformer with alternating DC current. At the end of 8 cycles, the transformer core is demagnetized.

The Transformer Ohmmeter's wide resistance range (1 micro-ohm to 1999 ohms) gives a high degree of resolution for even the lowest winding resistance tested.

Features include:

- Direct digital reading saves time, no manual balancing is required.
- Built-in discharge circuit safely discharges the specimen **when test is completed**, if lead accidentally disconnects, or if power is lost.
- Test indicator light gives a visual indication of either a charged or discharged specimen, even if power to the instrument is lost.
- Two independent measuring channels allow simultaneous testing of primary and secondary windings or measurement of two phases at a time.
- The sensitive tap-changer test circuitry monitors the contact operation of on-load tap-changers for their correct make-before-break sequence. If an open circuit condition exists, the instrument shuts down immediately.
- Electronically generated and patented regulated current supply overcomes high-inductance transformers quickly, allowing fast measurements to be taken. **Display of measurement occurs only after test current stabilizes.**
- Wide resistance range is suitable for testing a wide variety of transformers.
- Current ramp-up mode continuously tests input compliance voltage and sets the maximum current based on the specific test load.
- Lightweight and portable, the MTO is ideal for use in workshop or substation environments.
- Over temperature protection provides automatic current shutdown and indication to prevent instrument damage.
- Meets the requirements of both the European EMC and Low Voltage Directives.

It is recommended that the user becomes familiar with the MTO before making any connection to a transformer.

Top Panel Controls

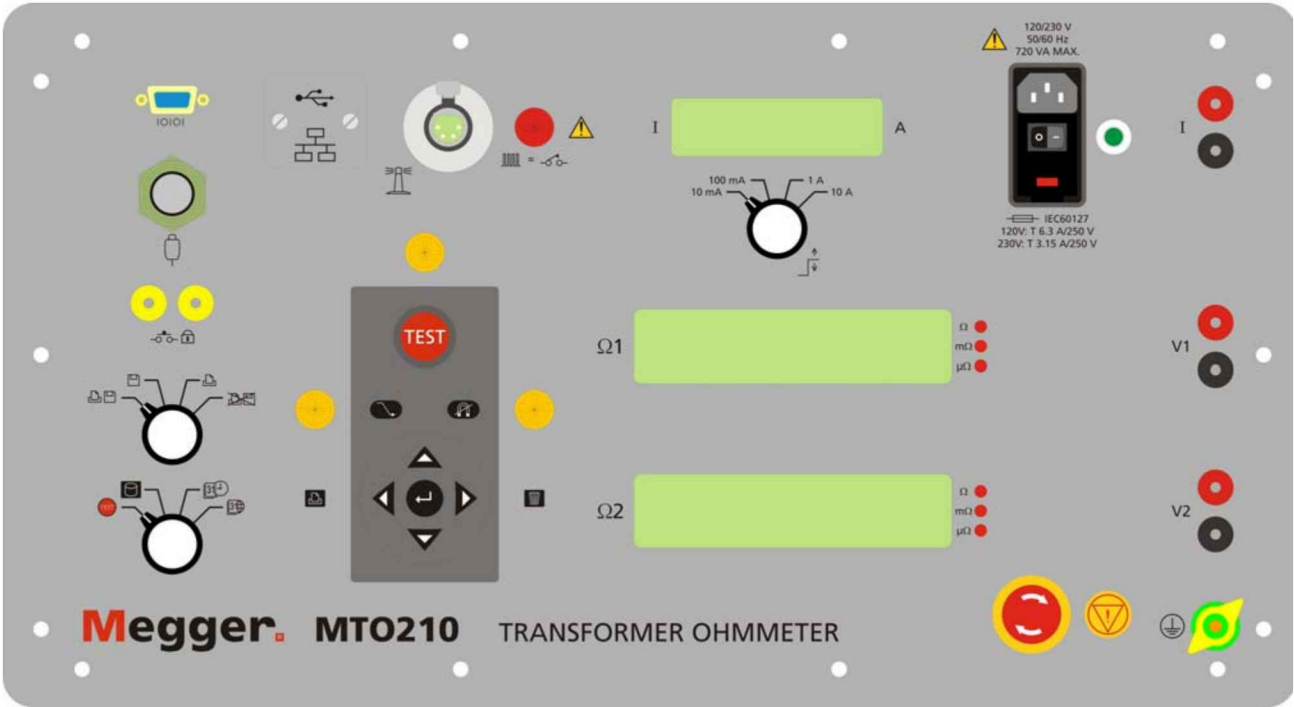

Figure 1: MTO210 Front Panel



Input AC Power Module:

This module is an IEC320 interface to the mains power. The module has an integrated switch, fuse holder and input filter module. Above the module are the voltage, frequency and power requirements for the product. Below the module are the fuse type and ratings based on the input voltage used. The green light on the right side of the module illuminates when power is ON.

- 0, OFF position
- , ON position

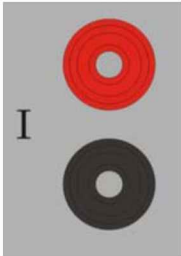

Output Current Terminals

These connections are used to connect to the transformer winding(s) and pass the DC power into the transformer winding for testing and demagnetization. The connection is capable of supplying up to 50 volts DC and up to 10 amps current.

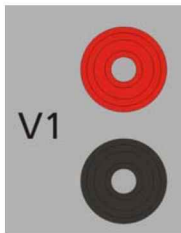

Input Voltage V1

These connections are used to connect a transformer winding for input voltage measurement. The instrument will automatically calculate the resistance of this input in combination with the current source. The connectors are also used as a path for current to flow during discharges. Voltage leads shall always be used in conjunction with current leads.

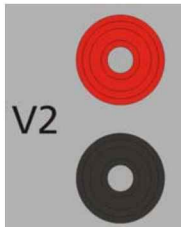

Input Voltage V2

These connections are used to connect a second transformer winding for input voltage measurement. The instrument will automatically calculate the resistance of this input in combination with the current source. The connectors are also used as a path for current to flow during discharges. Voltage leads shall always be used in conjunction with current leads.



Earth/Ground Lug

This connection is used to connect a transformer under test to earth ground for safety. The transformer and the MTO shall be at the power ground/earth potential when being operated.



Emergency Shut Down Switch

This switch, when pushed will disable the source power supply and automatically discharge the transformer. The instrument is continuously monitoring this switch in the event of an emergency. If the switch is engaged, no testing can commence.

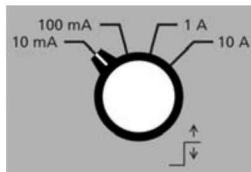

Current Set Switch

This switch is used to control the amount of current the instrument will use to test a transformer.

Symbol represents the maximum output level of test current.



Warning Beacon Connector

When the Warning Beacon is attached to the connector, the user will have a more visible indication of the activation mode of the MTO.

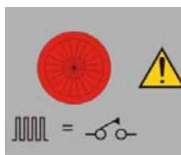

Break Before Make INDICATOR

During testing, the unit will indicate disruptions in the current loop. During testing of *On Load* tap changers, this indication will signify that a faulty break before make condition has occurred.

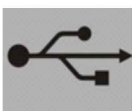

USB Interface

Not accessible at this time

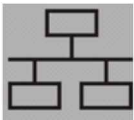

Maintenance Port

This port is provided for software upgrades and diagnostics, the interface panel can be removed and an Ethernet connection is available to attach the instrument externally to a PC. Port is NOT network compatible. This product is not intended for network use.

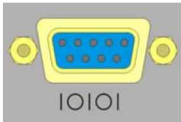

RS232 Connection

This connection is used for printing to a thermal 4" printer and/or transferring data from MTO to a user PC.

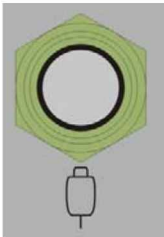

Remote Control Switch

This connector is used to interface with a remote switch. This switch is primarily used when the system is used for testing On Load Taps of a transformer

The Remote Control Switch can remotely start the MTO test and store multiple resistances reading for tap changes. The storage function in remote mode is sequential and occurs during a continuous resistance test. The unit will also store break before make events in local storage.

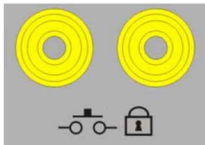

Interlock Connections

These connections are used in the event that testing requires lockout mechanisms from the transformer. If the Interlock connection is open, the unit will not be capable of going into Test Mode. If the interlock is broken during test, the unit will automatically shutdown and discharge an energized transformer. Further testing will be prohibited.

Data Output Mode Switch

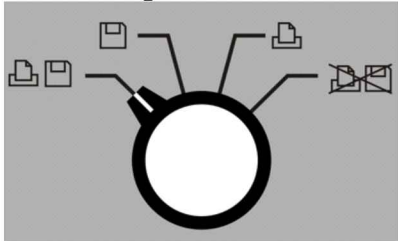

MTO will Print and Save Data



MTO will Save Data



MTO will Print Data



MTO will just Display Data

Function Mode Switch

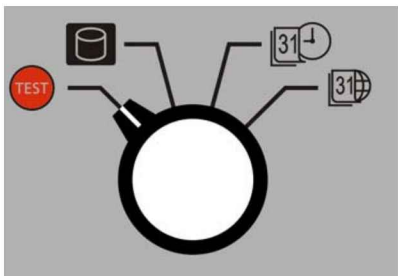

MTO is in Test Mode



MTO is in Storage Review Mode



MTO is in Set Date and Time Mode



MTO is in select Date Format Mode



IDLE STATE - When pushed the unit will start a test on a transformer. This will only occur if the instrument is in Test Mode (see Function Mode Switch above).

The TEST INDICATOR above the button will illuminate during the test.

TEST STATE – When pushed the unit will stop a test on a transformer, maintain the results on the screen. It will save and/or print the results dependent on the Data Output Mode Switch.



When pushed will stop testing and discharge the transformer. The DISCHARGE INDICATOR to the left will illuminate during the discharge cycle.



When pushed will perform a transformer demagnetization. The DEMAG INDICATOR to the right will illuminate during the demagnetization cycle.



When pushed, the unit will acknowledge data entry, displayed messages and during test mode, save data presented on the display.



Symbol highlights that the  button will PRINT the test results out the RS232 port when pushed and in Storage Review Mode.

In ready mode,  button will change the sensitivity of the current transition detection sensitivity. Off is default.



Symbol highlights that the  button will give the user the ability to DELETE the last recorded test in memory. If pressed a second time, the unit will give the user the ability to delete all tests in memory. If pressed a third time the unit will no longer be in the delete function.

In ready mode,  button turn toggle ON/OFF the OHM2 display.

2

Safety

Safety is the responsibility of the user

Only qualified and trained operators should operate the MTO system. Operator must read and understand this entire Instruction Manual prior to operating the equipment. Operator must follow the instructions of this Instruction Manual and attend the equipment while the equipment is in use. In the event of equipment malfunction, the unit should immediately be de-energized and returned to Megger for repair.

“The Safety precautions herein are not intended to replace your Company’s Safety Procedures. Refer to e.g. IEEE 62-1995/IEEE C57.152 and IEEE 510 - 1983, IEEE Recommended Practices for Safety in High-Voltage and High-Power Testing, for additional information.”



WARNING

When applying current to a transformer with very high inductance, additional care should be taken not to remove current or voltage leads while current is still flowing. This causes an extremely high voltage to develop across the point where current is broken. Under certain conditions, this voltage could prove to be lethal.

The Megger Transformer Ohmmeter has built-in safety protection thru the VOLTAGE POTENTIAL LEADS. Voltage leads shall always be connected in parallel with the current leads.

Example: If a current lead is disconnected while current is flowing through the transformer, the current will flow through the alternate path of the potential lead without damage to instrument or electrical shock to operator.



WARNING

It is very important not to connect any leads on top of or too close to one another. Take the necessary precautions to assure one lead falling off will not take a second lead with it.

General Safety Precautions

The MTO and the Unit Under Test (UUT) should both be considered as sources of instantaneously lethal levels of electrical energy. Observe the following safety precautions:

- Observe all safety warnings on the equipment. They identify areas of immediate hazard that could result in injury or death.
- Use this equipment only for the purposes described in this manual. Observe strictly the Warning and Caution information provided in this manual.
- Treat all terminals of high-voltage power equipment systems as potential electric shock hazards. Use all practical safety precautions to prevent contact with energized parts of the equipment and related circuits.
- Use suitable barriers, barricades and/or warnings to keep persons not directly involved with the work away from test activities.
- Never connect the test equipment to energized equipment.
- Do not use in an explosive atmosphere.
- Use the grounding and connection procedures recommended in this manual. Always disconnect test leads from power equipment before attempting to disconnect them at the test set. The ground connection **MUST** be the first made and removed last. Any interruption of the grounding connection can create an electrical shock hazard.
- Personnel higher than 5 feet should follow proper tie off safety requirements.
- Personnel should use proper safety gear to prevent bodily harm.
- Personnel using heart pacemakers should obtain expert advice on the possible risks before operating this equipment or being close to the equipment during operation.
- Fuse selection is dependent on input voltage. 230VAC uses 3.15 amp fuses and 120VAC uses 6.3 amp fuses.



WARNING

No user serviceable parts inside! Refer all servicing to the factory or a qualified authorized service company!

**CAUTION**

**Use only factory supplied mains cord!
Mains cord shall not be substituted!**

Input Power Precautions

This instrument operates from a single-phase, sine wave, power source. It has a three-wire power cord and requires a two-pole, three-terminal (live, neutral, and ground) type input source. The voltage to ground from the live pole of the power source must be within the following rated operating voltage:

For Cat. No MTO210: 120/230 V 10%, single-phase sine, 50/60 2 Hz

The neutral pole must be at ground potential. Before making connection to the power source, determine that the instrument rating matches the voltage of the power source. The power input plug must be inserted only into a mating receptacle with a ground contact.

**WARNING**

Do not bypass the grounding connection. Any interruption of the grounding connection can create an electric shock hazard. Determine that the receptacle is properly wired before inserting the plug.

The control circuits of the instrument are protected by two mains circuit fuses. These fuses are located in the ON/OFF switch module and are replaceable by the operator. To avoid electric shock and fire hazard, use only the fuse specified in Section 8 *Parts List and Optional Accessories*, that is identical in respect to type, voltage rating, and current rating. A detailed procedure for *Fuse Replacement* is defined in Section 7 - *Service*.

**WARNING**

Before replacing the fuses, disconnect the power input plug from the live power source.

Megger.

3

Preparing for a Test

Site Preparation

Choose a location that meets the following conditions:

- The location is as dry as possible.
- There is no flammable material stored in the vicinity.
- The test area is adequately ventilated.
- Be sure all equipment is de-energized and all terminals of the Unit Under Test (UUT) are accessible. Erect suitable safety barriers to protect the operator from traffic hazards and to prevent intrusion by unauthorized personnel. User provided Warning lights are recommended.
- Verify that the Local station ground is intact and has impedance continuity to earth.

Making Circuit Connections

Connections should be made in the order as listed below.

1. **Ground.** Use the Megger supplied Safety Ground Cable (15 ft (4.6 m)) to connect the MTO Wing Nut Ground Terminal directly to Local Station Earth Ground. Ensure that the Transformer chassis also has a low impedance connection to Local Station Earth ground potential.
2. **Input Power Source Ground.** Input Power Source Ground Terminal should be less than 100 milliohms of impedance to Local Station Earth Ground.
3. **Connect the Input Power Cord.** Before making this connection, insure the *Input Power Source* meets the requirements as listed in Section 2 *Safety* and Section 9 *Specifications*. Also make sure that the ON/OFF switch (Figure 1) is in the OFF position. Connect the input power cable to the MTO first, then to the power source. At this time, leave the ON/OFF switch in the OFF position.

4. **Connect the Serial Cable (optional).** If the user chooses to use an external printer or PC, using PowerDB Lite PC software, then connect the serial cable between the MTO and the printer or PC at this time.
5. **Connect the Remote Control cable (optional).** If the user chooses to operate the *Test Button*  of the MTO from a remote distance then, connect the RCC cable at this time.
6. **Connect Warning Beacon (optional).** If the user chooses to operate the *Warning Beacon* then, connect the WBC cable at this time and place the beacon in a conspicuous location.
7. **Connect Interlock Switch.** The MTO has an external interlock switch feature. Connect the external Interlock Switch via banana jack connection to the interlock input jacks on the front panel. The interlock switch function is a fail open, therefore if not used, an interlock jumper shall be placed in the jacks. If the circuit is open “IntLoc” will be displayed at the middle LCD.
8. **Connect the I and V leads (to the MTO end only at this time).** With the clamps disconnected from the UUT, connect the I and V cables to the MTO at this time. Be sure that all plugs are fastened securely to the MTO so they will not become loose even in the event of the operator inadvertently tripping over the current leads.

MTO210 is programmed to read two voltage inputs at all times. If a voltage input is not used, the high impedance input characteristics of the input cause the unit to give readings that are not zero. If a jumper is installed, the reading will be very low.

9. **Connecting to the Transformer.** When testing high-voltage transformers, caution must be used at all times and all safety precautions followed. Read, understand, and employ all safety precautions and circuit connections described in Sections 2 *Safety* and Section 3 *Preparing for Test*.



WARNING

Ensure that the transformer to be tested is completely de-energized. Check every winding. Ensure that all terminals of the transformer are disconnected from line or load at the transformer. Connections to ground may be left in place.



WARNING

For all testing as described herein, care shall be taken to ensure any and all unused clamps shall be isolated from each other, from ground, and from personnel.

At this time, make the connections to the Transformer Under Test (TUT), as described in the applicable section of Section 5, *Connecting to the Transformer Under Test*.

Megger.

4

Operating the MTO210

When testing high-voltage transformers, caution must be used at all times and all safety precautions followed. Read, understand, and employ all safety precautions and circuit connections described in Section 2 *Safety* and Section 3 *Preparing for Test*.



WARNING

Ensure that the transformer to be tested is completely de-energized. Check every winding. Ensure that all terminals of the transformer are disconnected from line or load at the transformer. Connections to ground may be left in place.



WARNING

For all testing as described herein, care shall be taken to ensure any and all unused clamps shall be isolated from each other, from ground, and from personnel.



EMERGENCY SHUTDOWN PROCEDURE

Press red EMERGENCY TEST OFF push button or switch power off.



Description of Test Sequence

Once all the precautions and steps of Sections 2 *Safety* and 3 *Prepare for Test* are complete, and the connections to the Transformer Under Test (TUT) have been made, then the input switch may be switched to the ON position.



0, OFF position

-, ON position

The MTO is operated by using the keypad on the front panel. On power up, a beep sound will occur, the test set performs a self-test check, and all hardware and software variables are initialized.

INITIALIZATION FUNCTION

The MTO performs startup diagnostics to assure the internal hardware is operational before testing transformers.

If an error code is displayed that is uncorrectable, return the instrument to Megger or an authorized service center for repair. Refer to Section 7 *Service* for repair instructions. If no errors are detected, the resistance and current displays will present dashes (-).

TEST FUNCTION

After a successful initialization function is completed, the user has the ability to go into any of four user functions. This section describes the TEST FUNCTION in detail.

1. Set the **Data Output Mode Switch** to the desired mode.

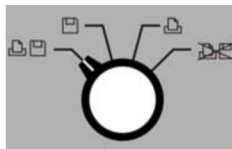

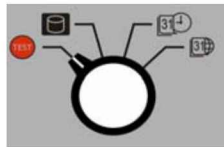

2. Set the **Function Mode Switch** to TEST mode.



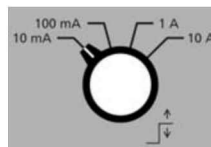

3. Set the **Current Range** required for test.





4. The current display window (I) will flash ready before a test sequence is initiated.
5. The OHM 1 display window will display the locally stored temperature that the unit will store with the resulting data for all subsequent tests. Press  and  to change the transformer winding temperature at the time of test.
6. The OHM 2 display window will display the Current Transition time sensitivity and if OHM 2 display is turned ON or OFF during testing.

Press  to change the transition sensitivity. 0 is off and the higher the number, the more sensitive the circuit will be for current transitions.

Press  to turn ON or OFF the OHM 2 display during testing.

7. locally stored temperature that the unit will store with the resulting data for all subsequent tests. Press  and  to change the transformer winding temperature at the time of test.

8. Press  and the unit will apply power to the transformer and attempt to charge the transformer to the maximum current set level. Once the current has stabilized, the unit will calibrate all inputs and take resistance readings continuously.

9. Press  during testing and the unit will save and/or print the displayed data (based on the setting of the Data Output Mode Switch). This button makes it possible to take multiple readings such as an on load tap changer test. The unit will display the test number in the current display and Saved in Ohm 2 display for 2 seconds to acknowledge the data saved.

10. Press  and the unit will turn off power to the transformer, store and/or print the data (based on the setting of the Data Output Mode Switch and display the data on the LCD display for review.

The data will stay on the LCD until another function or  is selected.

DISCHARGE FUNCTION



This button, when pushed will stop testing and discharge the transformer. The *Discharge Indicator* to the left will illuminate during the discharge cycle. No data is stored in the memory and/or output to printer.

The discharge of a transformer after testing is critical to prevent excessive voltage buildup across the transformer bushings upon removal of current. When the current source is disconnected, the energy in a transformer will continue to flow. If there is high impedance (air), the voltage across the inductor will increase until there is a current path found for the energy. This can be either an internal or external current path. It is possible to attach a shorting cable across the transformer bushings before the current source is turned off. Since the short has very little resistance, the circulating current thru the transformer and the short may continue for a very long period of time. The MTO discharge circuitry is

built-in. It will automatically initiate when the current source is disconnected from the transformer. It will also provide visual indication of discharging.

DEMAGNETIZATION FUNCTION



This button, when pushed will perform a transformer demagnetization. The *Demag Indicator* to the right will illuminate during the demagnetization cycle.

The demagnetization of a transformer after testing is critical for smooth transformer startup. If there is a large residual flux present in the transformer at startup, inrush currents on the primary side of the transformer may exceed relay settings for shutdown, therefore, it is advantageous to perform demagnetization after a winding resistance test sequence has been run and the transformer is scheduled back into service.

The MTO demagnetizes the transformer by automatically magnetizing the core of the transformer in the positive and negative direction with multiple cycles of reduced current. During the demagnetizations, the unit will display what cycle the unit is processing.

Demagnetization only needs to be accomplished once after all testing is complete. CURRENT and VOLTAGE leads should be attached to high side windings for more effective demagnetization.

The demagnetization cycle will take time for completion. It is equivalent to taking multiple tests in sequence.

REMOTE TEST FUNCTION

The main purpose of this function is to take sequential data to storage during a single test. It is useful for tap change testing where multiple resistance values are to be read in sequence with no test lead movement.

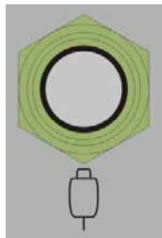

1. Connect Remote Control Cable to the remote connector on the front panel of the instrument.



2. Power ON (-) the instrument.

The Unit will detect the Remote Switch and display “rnnt 0/1”. The 0 is when the switch is not pushed; the 1 is when the switch is pushed. This is the

indicator that you are in Remote Mode and the button is functioning properly.

3. To start a test sequence, press  on the front panel. This will NOT cause the test to start but only illuminate the HV Indicator. The Remote Indicator will stay off.
4. The operator will go to the tap changer, verify it is in the correct starting position, and then to start the first test, press .



The Remote Indicator will slow flash to indicate charging. When the Remote Indicator goes steady the reading is stable.

5. Pressing  will cause the stable result to be saved to memory. The MTO is always monitoring for a tap change interrupts.

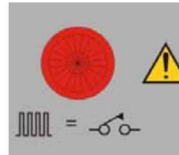
If a *Break Before Make* condition occurs the Break Before Make Indicator will flash rapidly.



Depending on the length of the break, one of two things will happen.

1. For short breaks, the unit will rapidly flash, but the system will continue to operate and give resistance readings. Press  to acknowledge and store the event or press  to delete the event.
2. For breaks longer than about 200 msec, the system will automatically shut down. The HV Indicator will extinguish and the Discharge Indicator and Remote Indicator will flash.

To extinguish the Break Before Make Indicator, press .



If no such condition exists the Remote Indicator will start slow flashing again until the circuit stabilizes from the tap change and then go steady when this setting has stabilized.

3. Press  to record the reading again and the process continues till all transformer taps are tested.

STORED DATA FUNCTIONS

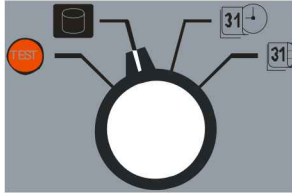







The MTO can save up to 2000 test results to memory for archival purposes. If data is stored while testing, the unit can step thru the memory after testing in a review process.



1. Set the Data Output Mode Switch into Storage Review Mode. The unit will come up with the last data stored in alternate mode. The logged test number and time of test will flash on the upper screen. By pressing , the unit will display detailed results of current and two resistance values. Pressing  will alternate between the two displays.

NOTE: *If the MTO storage is full, the message "Stor.Ag FULL" will be displayed at power up or at first time reviewing data.*



2. Press  and  to traverse the stored data.
3. Press  to print displayed data.
4. Press  to delete the last stored data from the unit. The unit will ask for confirmation with SURE on the OHM1 screen. Press  to confirm deletion.
5. Press  a second time to delete all stored data from the unit. The unit will ask for confirmation with SURE on the OHM1 screen. Press  to confirm deletion.
6. Press  a third time to get out of the delete mode.



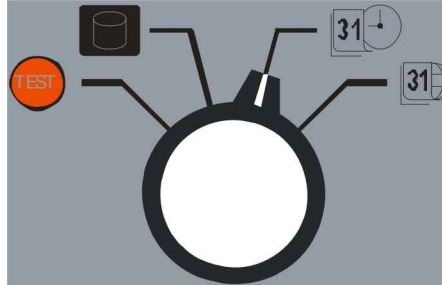

SET TIME FUNCTION

The MTO can set the Time of Day from the front panel interface. Set the function mode switch to the Date Time Setting as shown below.

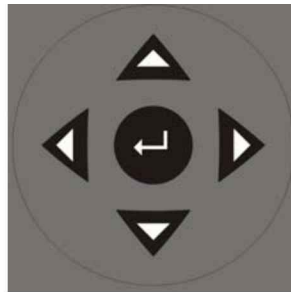

1. Set the Function Mode Switch into set time mode.



2. Use  and  to traverse thru the year, month, day, hour, minute and second. The active parameter will blink on and off.
3. Use  and  to increase or decrease the selected parameter.
4. Use  to confirm any changes made to selected parameters.

SET TIME AND DATE FORMAT

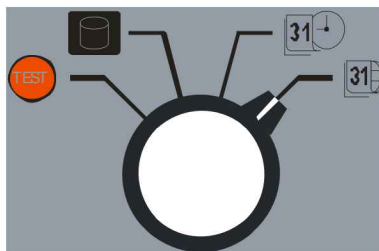

The MTO can change the Date Format.

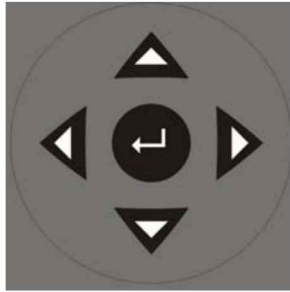

1. Set the Function Mode Switch to Date Format Mode.

Megger.



2. Press  and  to traverse from year/month/day to month/day/year to day/month/year.
3. Press  to confirm any changes made to selected parameters.

FIRMWARE UPDATE MODE

The MTO has two processors, commonly referred to as the bottom and top processor. Each processor requires software to function properly. This section describes the method for changing the firmware on an MTO

ATTAINING THE LATEST SOFTWARE:

The best way to attain the latest software is to visit Megger.com.

Once you are on the site,

1. Select the country you are located in.
2. You may have to register to log in on the site.
3. Select Software Downloads.
4. Select MTO. There should be a list of software available for download.
5. Select the latest firmware version available. The software is self contained as a ZIP file.
6. Download the file and run. The software will self extract and run automatically.
7. A Megger Welcome Screen will appear on the PC display. Before moving forward connect the PC to the MTO210 via an Ethernet cable.
8. Follow the instructions on the screen and the software will guide you thru the process of selecting the Ethernet Interface, verifying that the MTO is connected, power cycling the MTO to synchronize the boot loader with the PC, selecting the file for download and actually downloading the software.

Megger.

5

Transformer Testing



WARNING

When testing a transformer or regulator, make sure that a good ground is placed on the test specimen as shown on all connection diagrams.

Winding Resistance Testing

Winding resistance measurements in transformers are of fundamental importance for the following purposes:

Calculations of the I^2R component of conductor losses.

Calculation of winding temperature at the end of a temperature test cycle.

As a diagnostic tool for assessing possible damage in the field.

Transformers are subject to vibration. Problems or faults occur due to poor design, assembly, handling, poor environments, overloading or poor maintenance. Measuring the resistance of the windings assures that the connections are correct and the resistance measurements indicate that there are no severe mismatches or opens. Many transformers have taps built into them. These taps allow ratio to be increased or decreased by fractions of a percent. Any of the ratio changes involve a mechanical movement of a contact from one position to another. These tap changes should also be checked during a winding resistance test.

Regardless of the configuration, either star or delta, the measurements are normally made phase-to-phase and comparisons are made to determine if the readings are comparable. If all readings are within one percent of each other, then they are acceptable. Keep in mind that the purpose of the test is to check for gross differences between the windings and for opens in the connections. The tests are not made to duplicate the readings of the manufactured device which was tested in the factory under controlled conditions and perhaps at other temperatures.

Transformer winding resistances are measured in the in order to check for abnormalities due to loose connections, broken strands, and high-contact resistance in tap changers. Interpretation of results is usually based on a comparison of measurements made separately on each phase in the case of a

wye-connected winding or between pairs of terminals on a delta-connected winding. Comparison may also be made with original data measured in the factory.

Testing a Single-Phase Transformer

SINGLE-WINDING TEST

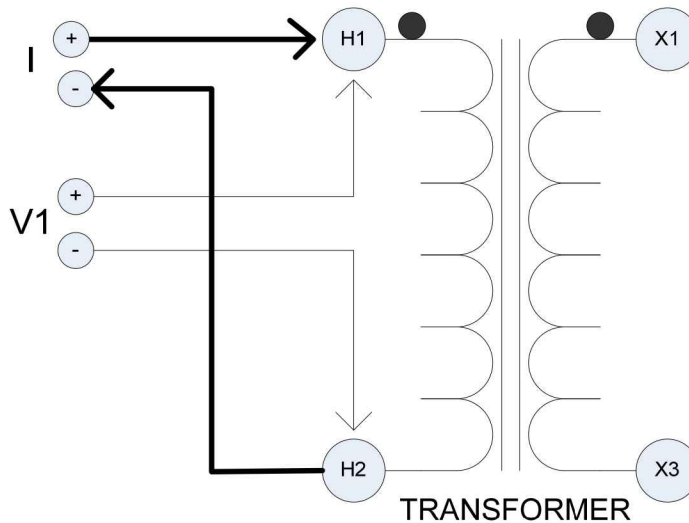

Figure 2: Single Winding Measurement



WARNING
Do not disconnect leads until all indicators are OFF!

PROCEDURE:

1. Connect line cord to unit and plug into 120 V/230 V socket.
2. Connect Safety GND cord from Top Panel to Transformer GND.
3. Set the following conditions:

a.

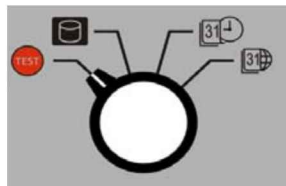

Set to **TEST** position.

b.

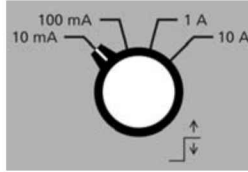

Set to desired **MAXIMUM TEST CURRENT**.

c.

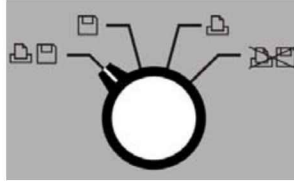

Set to desired **DATA OUTPUT**.

4. Connect "V1" voltage leads to test specimen winding. Do not clip potential leads on the current leads, since this will add contact resistance to the measurement. See Figure 2.

Connect current output (I) to test specimen winding. See Figure 2.

5. Turn power switch "ON" (-).
6. Press  button to initiate current flow.
7. The top smaller display indicates current output and the Ohm1 display indicates resistance of specimen.

NOTE

For larger transformers, the resistance display should be observed and resistance readings taken when the reading stabilizes. The drift in the indicated resistance reading is due to the inductance of the transformer. For small transformers the drift lasts for only a few seconds; for single-phase high voltage transformers (500kV), the drift may last for a fraction of a minute; for large delta connected transformers the settling time may be much longer, see section "Testing Delta Connected Windings". A 345MVA, 500kV single-phase transformer requires approximately 2 minutes for the display to settle.

8. When measurement is complete, press  to terminate measurement and discharge current. Discharge is complete when the discharge indicator is off.
9. Remove the current leads from the transformer.
10. Remove the potential leads from the transformer.

DUAL-WINDING TEST

This procedure describes the testing of both windings (high and low) on a single-phase transformer at the same time.

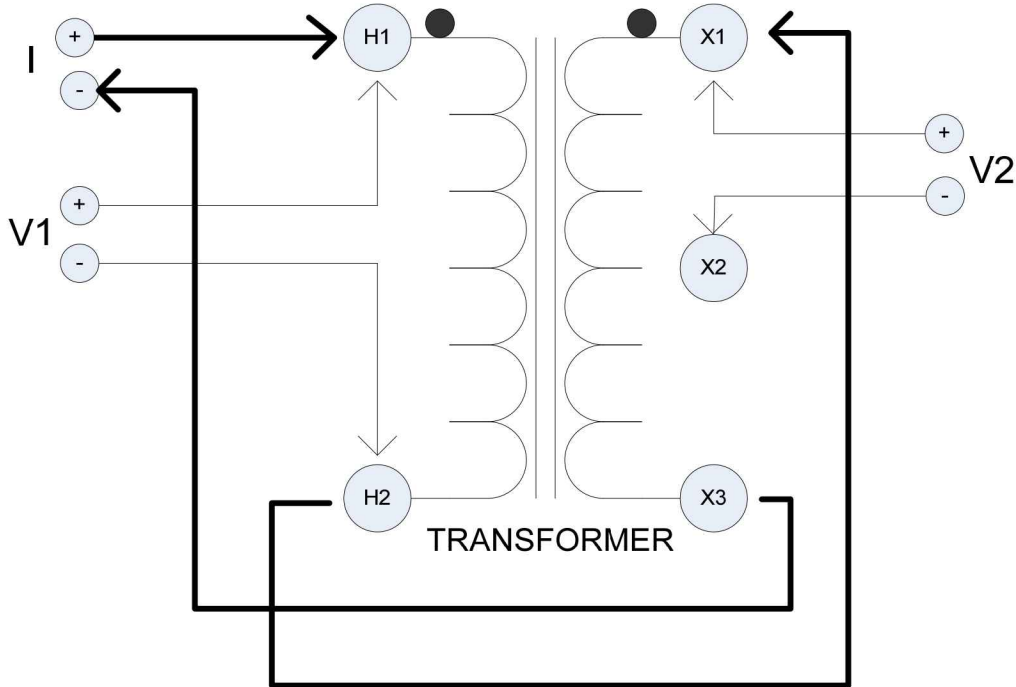

Figure 3: Dual-Winding Test



WARNING

Do not disconnect leads until all indicators are OFF!

NOTES: It should be carefully noted that the jumper in Figure 3 be connected to opposite polarities of transformer to reduce transformer core saturation time.

If the resistance between the 2 windings is greater than factor of 10, you may get a more accurate reading by testing the windings separately.

PROCEDURE:

1. Connect line cord to unit and plug into line socket.
2. Connect Safety GND cord from Top Panel to Transformer GND.

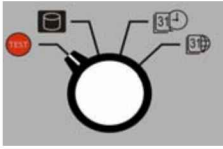
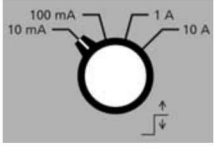
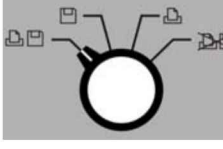

3. Set the following conditions:

- a.  Set to TEST position.
- b.  Set to desired MAXIMUM TEST CURRENT.
- c.  Set to desired DATA OUTPUT.

- 4. Connect "V1" voltage leads input to H1 and H2 terminals of test transformer. See Figure 3.
- 5. Connect "V2" voltage leads input to X1 and X2 terminals of test transformer. See Figure 3.

Connect current leads (I) to test specimen winding. See Figure 3. Add the Jumper Cable from H2 to X1. This will allow current to flow from the primary winding to the secondary winding. **Voltage leads should always be placed inside (between) current leads and the transformer.** See Figure 3.

NOTE: Always try and keep the polarization of the transformer the same for improved transformer charge time. If the positive lead for the current is connected to the positive terminal of the primary winding, follow this procedure by driving the current from the primary winding H2 jumpered to the positive terminal of the secondary winding X1.

- 6. Turn power Switch "ON" (-). Press  button to initiate current flow.
- 7. The top smaller display indicates current output and the Ohm1 display indicates resistance of primary winding and Ohm 2 display indicates the resistance of the secondary winding specimen.
- 8. When measurement is complete, press  to end the measurement and discharge current. Discharge is complete when discharge indicator is OFF(0).

Temperature Correction

It may be necessary to convert the resistance measurements to values corresponding to the reference temperature in the transformer test report.

To estimate the winding temperature at the measurement is important. If the transformer has winding temperature, use these readings. If not, the winding temperature is assumed to be the same as the oil temperature under the following conditions:

The transformer has been out of service for at least 3 hours

The temperature of the insulating liquid has stabilized, and the difference between the top and bottom temperature does not exceed 5°C.

If the transformer is measured without oil, the winding temperature is normally assumed to be the same temperature as the surrounding air.

Conversion of Resistance Measurements

Winding resistance measurements are normally converted to a standard reference temperature.

The conversions are accomplished by the following formula:

$$R_s = R_m (T_s + T_k) / (T_m + T_k)$$

where

R_s = resistance at desired temperature T_s

R_m = measured resistance

T_s = desired reference temperature

T_m = temperature at which resistance was measured

T_k = 234.5 (copper)

T_k = 225 (aluminum)

Testing a Three-Phase Transformer

The following details the different methods to be used in testing three-phase transformers. The measurements taken will be for one or two winding(s) at a time. Connection diagrams (Figures 4 thru 7) are to be used in conjunction with procedure "Single-Phase Transformer Test". The only changes will be placement of leads.

NOTE: When testing Primary and Secondary windings simultaneously, always try and keep the polarization of the transformer the same for improved transformer charge time. See Table 1.

PROCEDURE:

1. Three-Phase Wye Configured Winding with Neutral

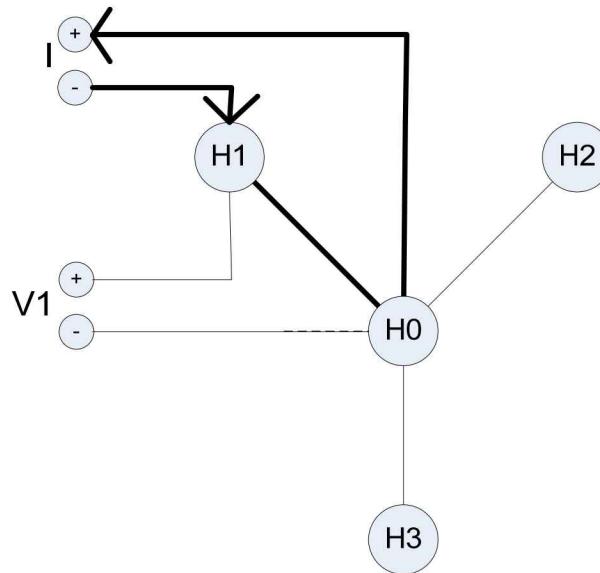

Figure 4: Reading obtained is per phase, Resistance of A-N Winding

Use the above diagram in conjunction with procedure "Single-Phase Transformer Test".

2. Three-Phase Wye Configured Winding, No Neutral Brought Out

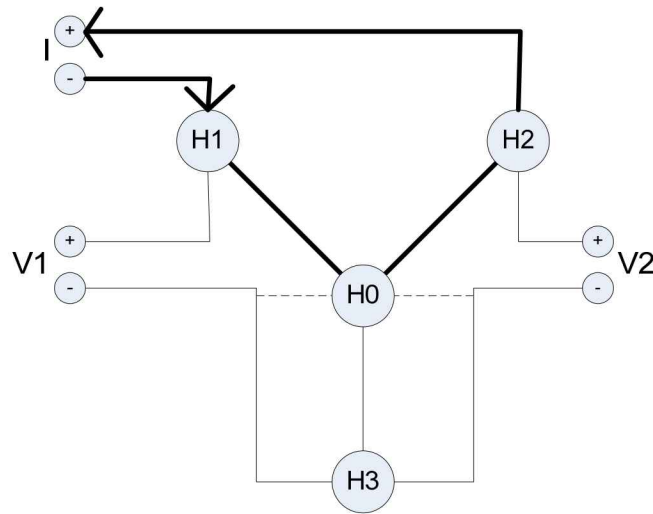

Figure 5: Reading obtained is between pairs of terminals, Resistance of A and B Windings

Use the above diagram in conjunction with procedure "Single-Phase Transformer Test".

3. Three-Phase, Delta Configured Winding

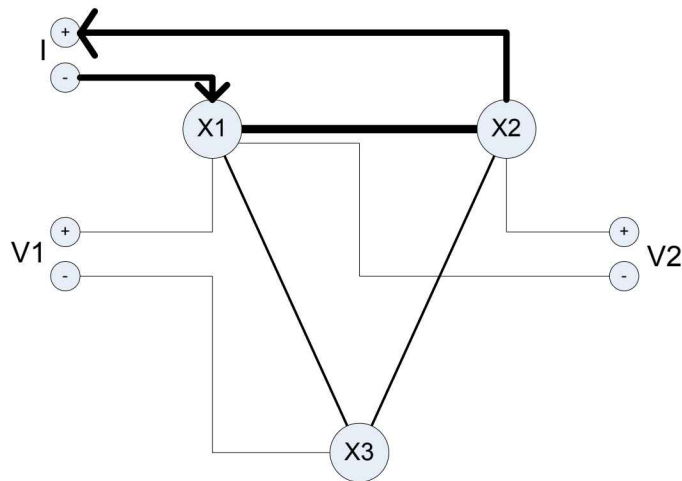

Figure 6: Reading is between pairs of terminals. Resistance of A in parallel with B+C Windings

Use the diagram in Figure 6 in conjunction with procedure "Single-Phase Transformer Test".

Testing Delta Configured Windings

Testing Delta winding resistance may be a very time consuming procedure, in particular LV winding deltas the correct balance time can take up to 30-60 minutes for a large transformer, which far exceeds the time restriction of many tests.

The method for quickly testing delta configurations requires that both the high side and low side be connected in series with the MTO's current source (see connection Table 1). By using both HV and LV windings to magnetize the core, the effective test magnetization current increases with the turn ratio. As an example, testing the Low Voltage side of a 100/10 kV Yd transformer with dual side injection at 10A is the same as testing only the Low Voltage side of that same transformer 68 A. Even if only one side of the transformer needs to be tested, connecting both high and low windings in series will speed the test up by a factor of 10 or more.

DELTA WINDING RESISTANCE

Manufacturer's winding resistance data are usually presented as per winding for Y configurations and per terminal pairs for Delta windings. In the rare case that manufacturer's data is presented per winding also for a delta connection, the recommendation is to recalculate the numbers to terminal pairs and compare with the field measurement results.

R_{avg} = Average individual winding resistance

R_{tp} = Winding resistance between terminal pairs

$R_{tp} = R_{avg} * 0.6667$

TABLE 1.
EXAMPLES ON TRANSFORMER CONNECTION SCHEMES
FOR
INJECTING TEST CURRENT AND MEASURING TWO WINDINGS
SIMULTANEOUSLY

Vector Group	Measurement setup						
	Current Connections			Meas ch 1		Meas ch 2	
	+ Current	Jumper	- Current	+	-	+	-
Dd0	H1	H3-X1	X3	H1	H3	X1	X3
	H2	H1-X2	X1	H2	H1	X2	X1
	H3	H2-X3	X2	H3	H2	X3	X2
Dyn7	H1	H3-X0	X1	H1	H3	X0	X1
	H2	H1-X0	X2	H2	H1	X0	X2
	H3	H2-X0	X3	H3	H2	X0	X3
Dyn1	H1	H3-X1	X0	H1	H3	X1	X0
	H2	H1-X2	X0	H2	H1	X2	X0
	H3	H2-X3	X0	H3	H2	X3	X0
YNyn0	H1	H0-X1	X0	H1	H0	X1	X0
	H2	H0-X2	X0	H2	H0	X2	X0
	H3	H0-X3	X0	H3	H0	X3	X0
Ynd1	H1	H0-X1	X2	H1	H0	X1	X2
	H2	H0-X2	X3	H2	H0	X2	X3
	H3	H0-X3	X1	H3	H0	X3	X1
Dy1	H1	H3-X1	X2	H1	H3	X3	X2
	H2	H1-X2	X3	H2	H1	X1	X3
	H3	H2-X3	X1	H3	H2	X2	X1
YNd7	H1	H0-X2	X1	H1	H0	X2	X1
	H2	H0-X3	X2	H2	H0	X3	X2
	H3	H0-X1	X3	H3	H0	X1	X3
Dyn5	H1	H2-X0	X1	H1	H2	X0	X1
	H2	H3-X0	X2	H2	H3	X0	X2
	H3	H1-X0	X3	H3	H1	X0	X3
Dy11	H1	H3-X1	X3	H1	H3	X1	X3
	H2	H1-X2	X1	H2	H1	X2	X1
	H3	H2-X3	X2	H3	H2	X3	X2
Dyn11	H1	H2-X1	X0	H1	H2	X1	X0
	H2	H3-X2	X0	H2	H3	X2	X0
	H3	H1-X3	X0	H3	H1	X3	X0

Testing Transformers with Tap Changers

Many transformers used today have taps built into them. These taps allow ratio to be increased or decreased by a few percent. Any of the ratio changes involve a mechanical movement of a contact from one position to another. It is this contact that needs to be checked by way of its contact resistance and mechanical integrity.

The contact may go bad for a number of reasons.

1. Misaligned when manufactured causing insufficient surface contact. Full load current overheats contact surface causing it to burn.
2. Current passing through contact exceeds full load rating.
3. Tap changing operation failing to have the required "Make Before Break" sequence will create internal arcing of contact surface.
4. An off-load tap changer is switched while on load. Contact surface becomes pitted and uneven.

Tap changers are divided into two types; "On-load" and "Off-load". The "On-load" tap changer allows selection of ratio change while the transformer is in service. This would mean the ratio of a transformer can be changed while power (current) is still passing through it. The most common example of this type of "On-load" tap changer is a "Voltage Regulator".

The MTO is ideally suited to test "On-load" tap changers because the instrument can be left ON while changing from tap to tap. This allows the operator to take measurements very quickly without discharging, then re-charging the transformer for every tap. The MTO will re-balance after every tap change. If the tap is defective (open) or if there is even a fraction of time (1ms) where circuit is open, the MTO will indicate an open circuit. If the current interruption is longer than about 10 ms, the MTO will stop the test and discharge the transformer automatically. This gives the operator a clear indication of a possible fault within the tap changer. For this OPEN condition, no damage will be done to the transformer by the MTO's DC current.

The second type of tap changer is the "Off-load". This is not as common as "On-load" because in order to change taps, the transformer has to be taken out of service or at least disconnected from the load. The MTO will test "Off-load" taps, but the transformer must be discharged between tap changes. If the transformer is not discharged between tap changes, damage can result in the transformer or the test unit

Testing Voltage Regulators

This procedure describes the basic connections to a single-phase regulator. The main test for a regulator is the evaluation of the condition of the tap positions. Because there are a large number of taps (typical 15 to 32), this test would normally take a very long time. With the MTO, this test time is drastically reduced because the instrument will stay on while changing “On load” tap positions.

All regulators have internal bridging reactors. It is because of these reactors that stabilization time for the MTO will vary. On odd position taps, balance time will be longer than even positions. This is due to circulating current generated when on odd positions and is shown below:

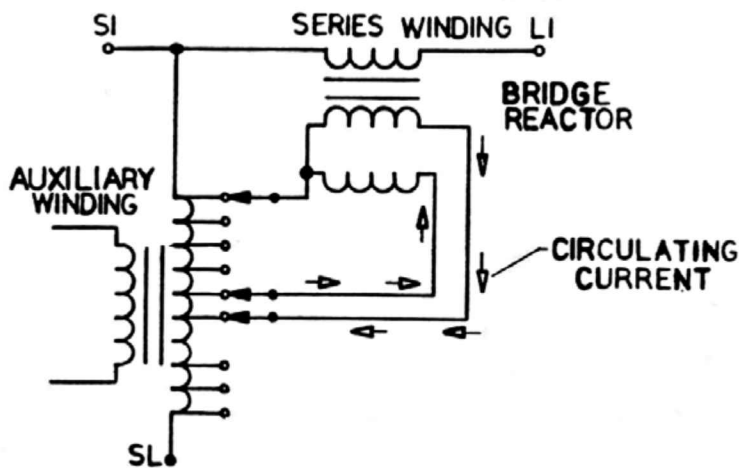

Figure 7: Odd Position Tap

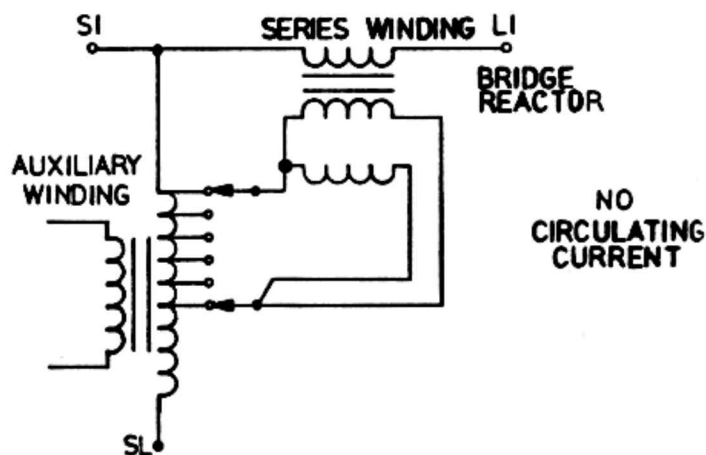

Figure 8: Even Position Tap

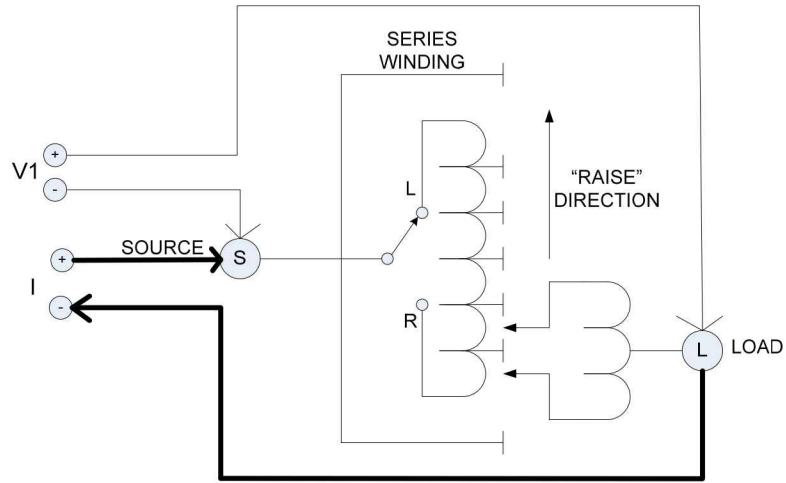

Figure 9: Connection to a Regulator



WARNING
Do not disconnect leads until all indicators are OFF.

PROCEDURE

1. Connect line cord to unit and plug into 120/240V socket.
2. Set the following conditions:

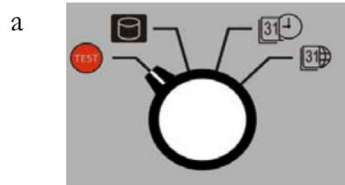

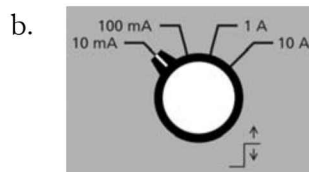

Set to **TEST** position.

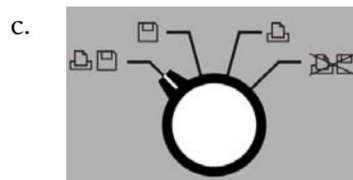

Set to desired max test current.



Set **DATA OUTPUT MODE**.

3. Connect "V1" voltage leads to test specimen winding. See Figure 9.
4. Connect current leads (I) to test specimen winding. Do not clip voltage leads on to the current leads, since this will add contact resistance to the measurement. **Voltage leads should always be placed inside (between) the transformer and the current leads.** See Figure 9.
5. Turn power switch "ON" (-).
6. Press  button to initiate current flow.
7. The top display indicates current output and Ohm 1 display indicates resistance.
8. Step thru the TAPS of the "On load" tap changer. The resistance should change slightly with each TAP change. Press  to save and/or print the readings of each tap.

If a Break Before Make condition occurs the Break Before Make Indicator will flash rapidly.

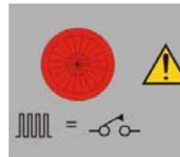



Depending on the length of the break, one of two things will happen.

1. For small breaks, the unit will rapidly flash, but the system will continue to operate and give resistance readings.
2. For breaks longer than 10msecs, the system will automatically shut down. The HV Indicator will extinguish and the Discharge Indicator will flash.

To extinguish the Break Before Make Indicator after an event, press .

If no such condition exists the Remote Indicator will start slow flashing again until the circuit stabilizes from the tap change and then go steady when this setting has stabilized.

3. Press  to record the reading again and the process continues until all transformer taps are tested.

4. When measurements are complete, press  to terminate and discharge current. Discharge is complete when the discharge indicator is off.

Demagnetizing a Transformer

The MTO demagnetizes the transformer by automatically magnetizing the core of the transformer in the positive and negative direction with multiple cycles of reduced current. The demagnetization function is equivalent to generating test currents for multiple resistance tests. During the demagnetizations cycle, the unit will display the number of cycles left in the process.

1. Demagnetization only needs to be accomplished once after all testing is complete.
2. CURRENT and VOLTAGE leads should be attached to one phase/terminal pair on high side (Primary) windings for more effective demagnetization.
3. Voltage Leads need to be attached. Just like a test. Discharge energy is absorbed through the voltage leads.
4. Only one Winding needs to be demagnetized on a three phase transformer.

Megger.

6

MTO210 Series PowerDB Lite

Introduction

PowerDB Lite is a free, but limited capability, version of the PowerDB software tool that is designed specifically to control and/or extract data from Megger instruments. The primary difference between PowerDB Lite and PowerDB is that PowerDB is designed to work with all manufacturers' equipment and has field and office synchronization capabilities. PowerDB Lite will present your test data into a professional looking data form that can be sent to a printer or .pdf file distiller such as PDF995.

PowerDB Lite allows you to use a sub-set of the standard PowerDB forms that are appropriate for specific Megger instruments. PowerDB Lite detects the instrument and enables the appropriate form(s). Data can be entered on-screen or captured directly while using the test instrument. Completed data forms can be saved as files to your computer.

For more information, or updates to the software, visit www.PowerDB.com.

Minimum Recommended System

- Operating System: Windows 2000 or later
- RAM: 64 MB RAM minimum, 512+ MB RAM recommended
- Processor: 300 MHz Pentium Class processor minimum, 1 GHZ or better recommended

For information about the features of the full version of PowerDB please visit our website at www.powerdb.com. Get acquainted with the following features by scheduling a live demonstration at info@powerdb.com.

- Synchronize all of your test records into a Single Corporate Database
- Reduce Test Time
- Improve Data Integrity
- Standardize Test Procedures
- Easily use Historical Trending for evaluation of Test Results

- Eliminates the need to install and maintain a software application per instrument
- Eliminates all hand written test sheets
- Create your own test forms
- Use or modify one of our 200 built-in test forms
- One-step procedure to generate test reports with table of contents and deficiency summaries
- Allows all of your field test data to be integrated with CMMS systems such as Maximo or SAP
- Imports >From Many Other Industry Standard Software Applications
- Controls and Imports Data from many non-Megger Instruments

Software Installation

To install PowerDB Lite, load the PowerDB Lite CD into your CD-ROM drive and follow the on-screen instructions.

1. Accept the terms of the License agreement.

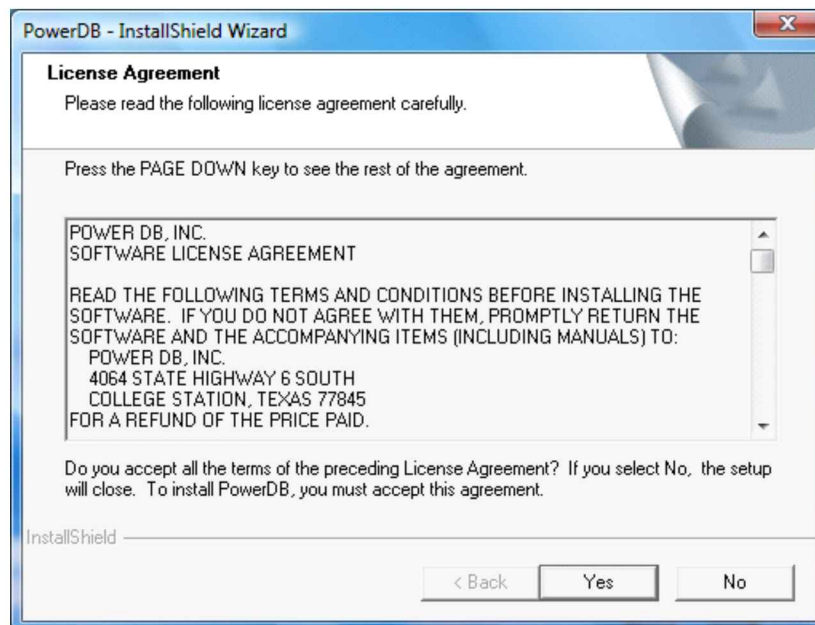

2. Choose the destination location for the PowerDB Lite files.

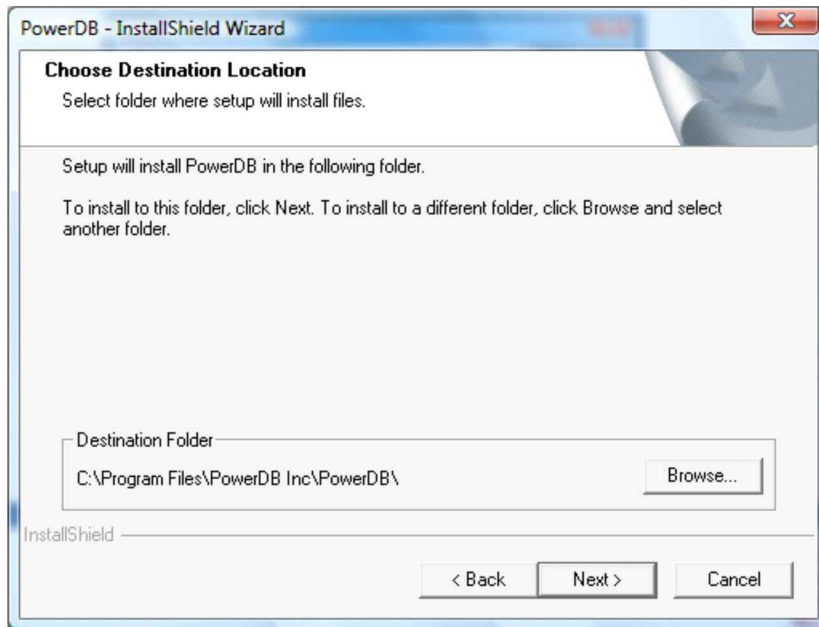

3. Select Default Settings.

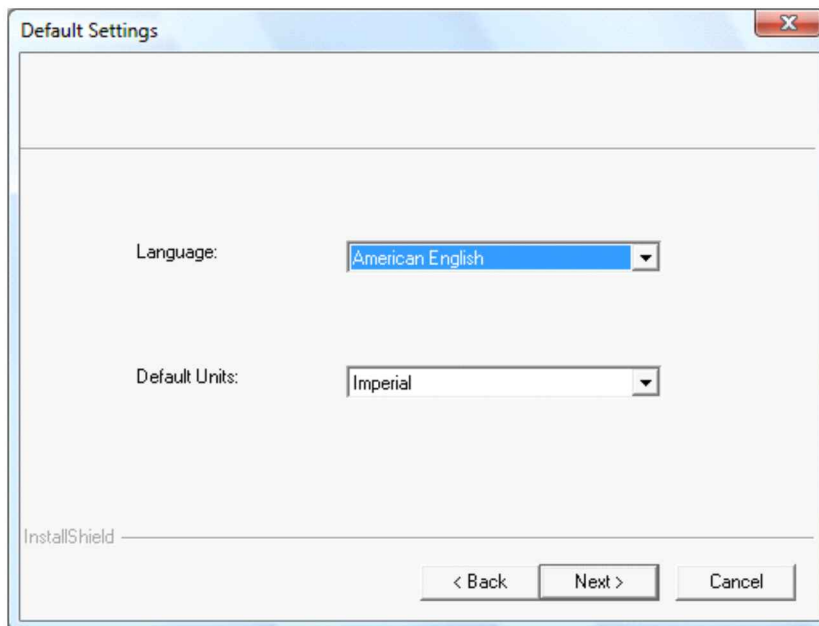

4. InstallShield Wizard will complete the installation of PowerDB Lite. Click **Finish** to close the installation program.

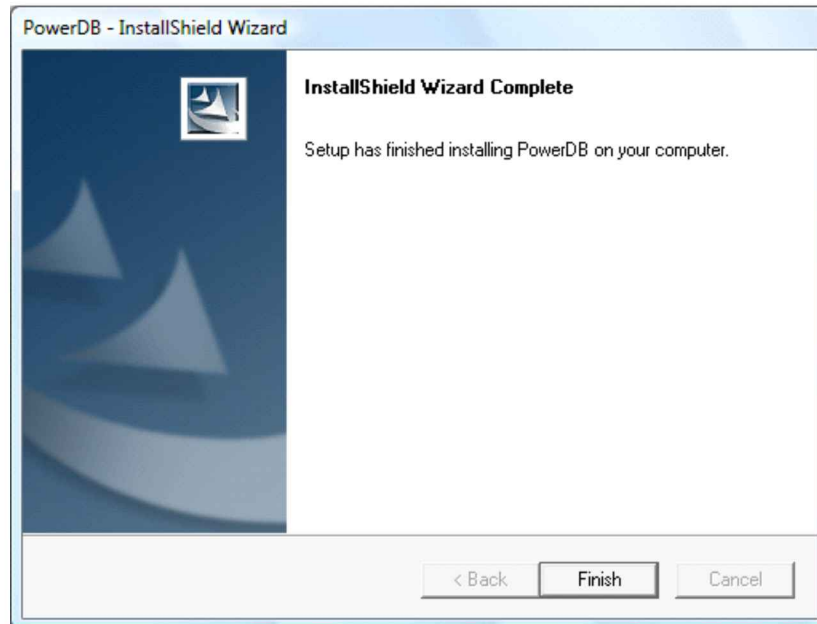

Using PowerDB Lite

1. HOME

1. Select your Instrument MTO210 from the Instrument Setup screen.
 - a. You can always view the Instrument Setup screen from the Tools menu or F3.

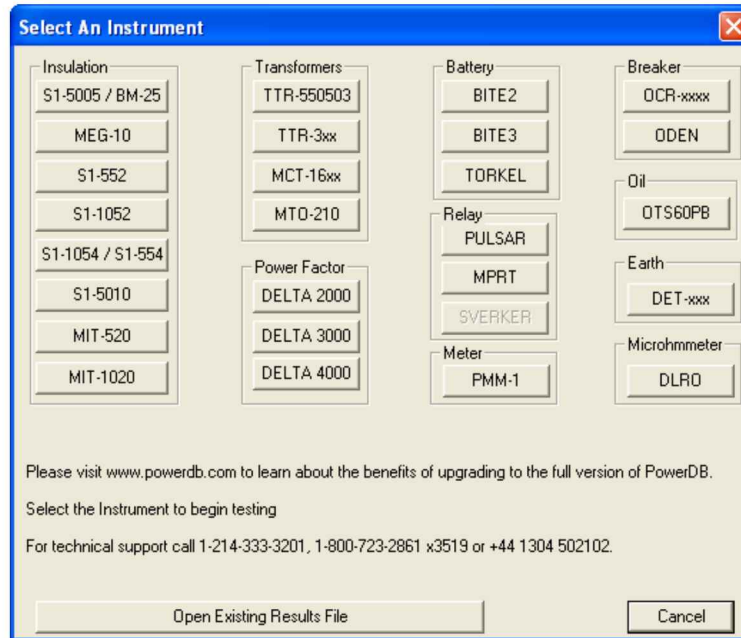

- b. The MTO uses serial communication. Select the appropriate communication settings on the *Serial Device Configuration* screen.
- c. Use the Refresh button to find any ports that may have not been connected at the startup of PowerDB Lite. If you are using a USB serial port and do not know the port assigned to it please perform the following:
 1. Remove the USB serial adapter.
 2. Press **Refresh**.
 3. Click on the **Port Drop Down** and record the options.
 4. Plug the adapter back in.
 5. Press **Refresh**.
 6. Select the port that was not in the original list.

Verify that the baud rate is set to 9600, Parity is set to none, Byte Size is set to 8, and Stop Bits is set to 1.

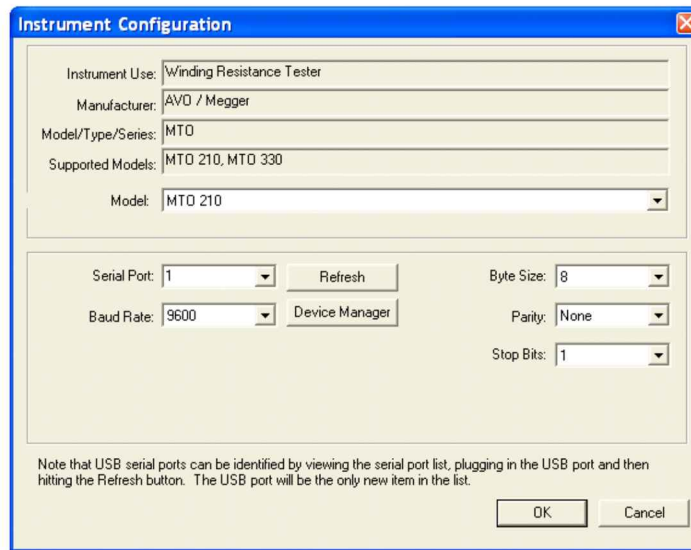

d. Click **OK** on the Instrument Setup Screen to finish.

2. SELECT A FORM

Once you have defined the instrument, PowerDB will present the forms created in the database and associated with that instrument. The factory default form is 56352.

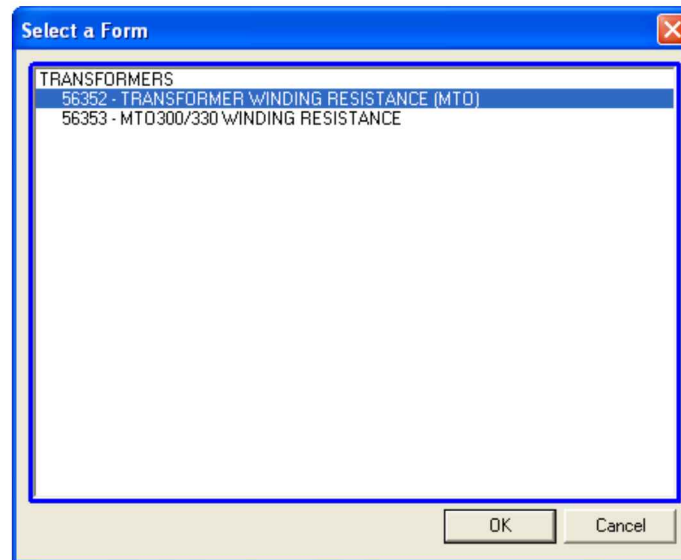

3. ENTER TEST DATA

- a. Header and nameplate information can be manually typed into a form.
- b. **Download Test Data** – Pressing this screen button will automatically download all of the data from the MTO.
- c. **Delete Selected Records** – When PowerDB Lite is connected to the MTO, the user can select tests from the list of displayed downloaded tests and delete those specific tests.
- d. **Delete ALL Test Data** – When this software button is pressed, all of the data in the instrument will be deleted.

TRANSFORMER WINDING RESISTANCE TEST

CUSTOMER _____ PAGE _____
 ADDRESS _____ JOB # _____
 USER _____
 OWNER REPRESENTATIVE _____ TELEPHONE _____
 DATE 4/3/2009 AMBIENT TEMPERATURE _____ °C HUMIDITY _____ % EQPT. LOCATION _____
 SUBSTATION _____ POSITION _____

TEST RESULTS

DELETE	TEST#	DESCRIPTION	DATE	TIME	R1	R2	CURRENT	SBM
<input type="checkbox"/>								

4. COMMENTS AND DEFICIENCIES

When imported into the full version of PowerDB, the comments and deficiencies on each form are used to generate summary reports. These summary reports repeat the notations and lists the page number where reported. This allows the user to scroll to a particular page to view a reported anomaly. For more information on features of PowerDB visit us at our website at www.PowerDB.com.

5. SAVE THE DATA

- a. Select the *File>Save* menu item, or press *CTRL+S*, or press the *Save* toolbar button.
- b. The Save As screen will allow you to specify a location and file name for your PowerDB Lite XML file.

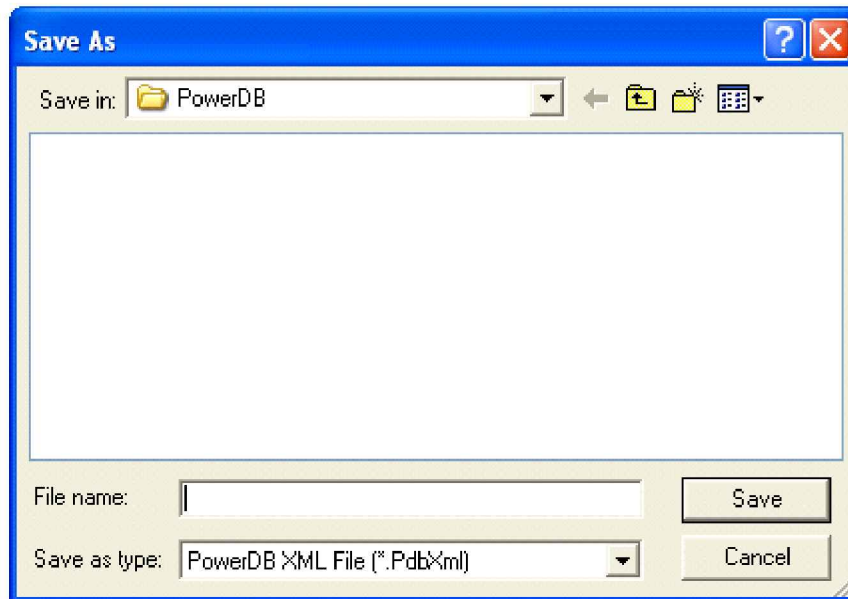

6. OPENING AN EXISTING FILE

- a. Select the *File > Open* menu item.

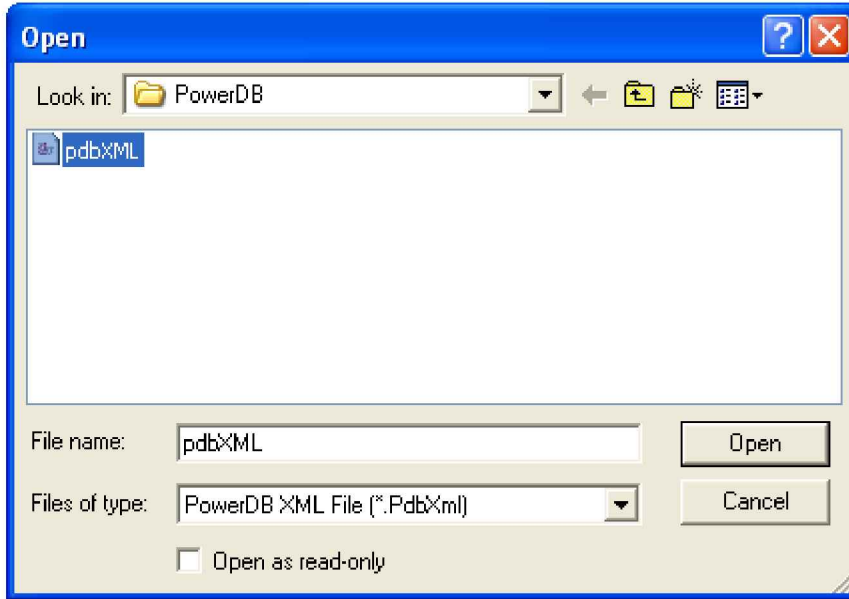

- b. **Browse** to the file you would like to open.
- c. Press the **Open dialog** button.
- d. If the file contains multiple test dates, select the *Date* that you would like to open for editing or select *New* to append a new set of results to the file. To remove a set of results, click on the selected file and press the *Delete* button.

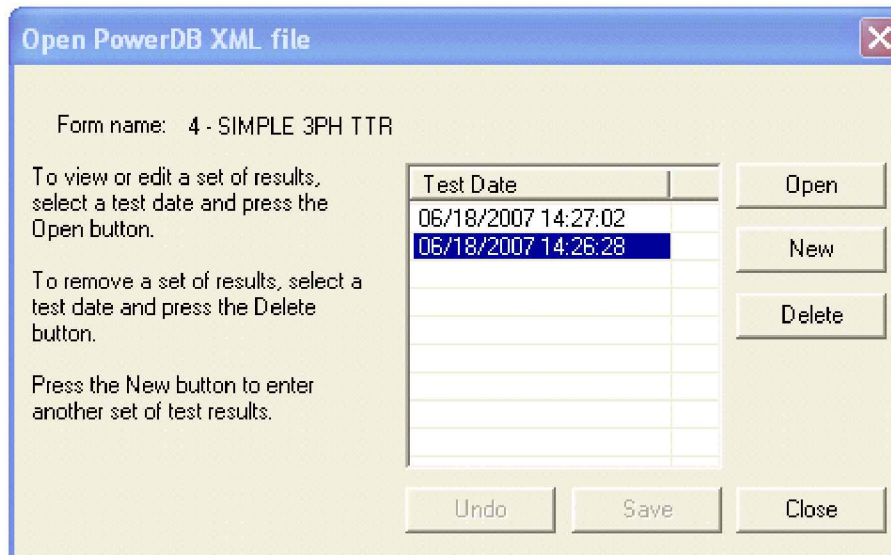

7. SETTING THE LOGOS

- a. Select the *Tools>Options* menu item.
- b. The Logos section specifies paths to the left and right logos files to use.
- c. To change the left logo press the “...” button by the left logo path.
- d. The Open Screen allows you to browse to a file location, select a .JPG or .BMP file, and press the **Open** button.
- e. Repeat steps (c) and (d) for the right logo path.
- f. Note that a logo will not be shown if the logo file path is blank or the file does not exist.
- g. Note after specifying the logo files the image will not be shown until the next time a form is opened (*File>Open*, or the *File>New* menu items).
- h. Note that the logos will look the best if the resolution of the file is 240 pixels wide by 240 pixels high. DPI is not important.

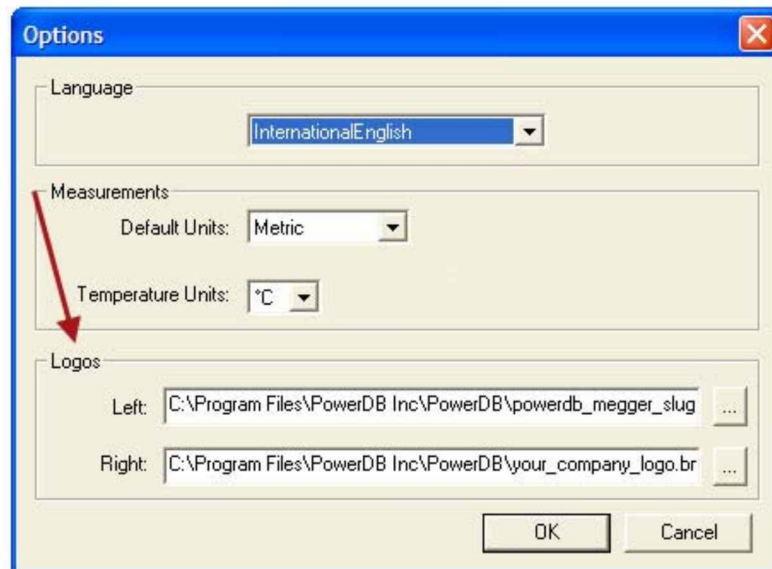

8. HOW TO CHANGE LANGUAGES

- a. Select the *Tools>Options* menu item.
- b. Select the appropriate language in the dropdown menu.

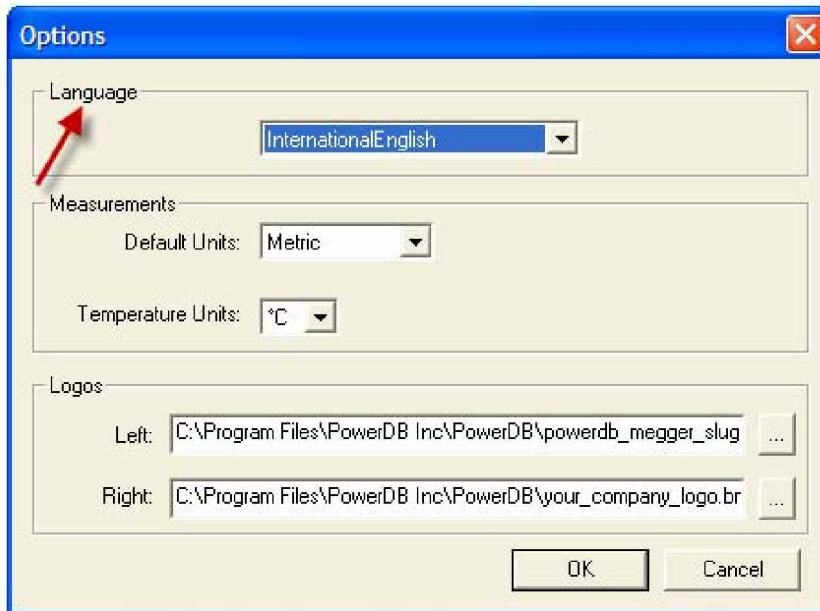

9. HOW TO CHANGE UNITS OF MEASUREMENT

- a. Select the *Tools> Options* menu item.
- b. Select the units in the drop down *Default Units under Measurements*.

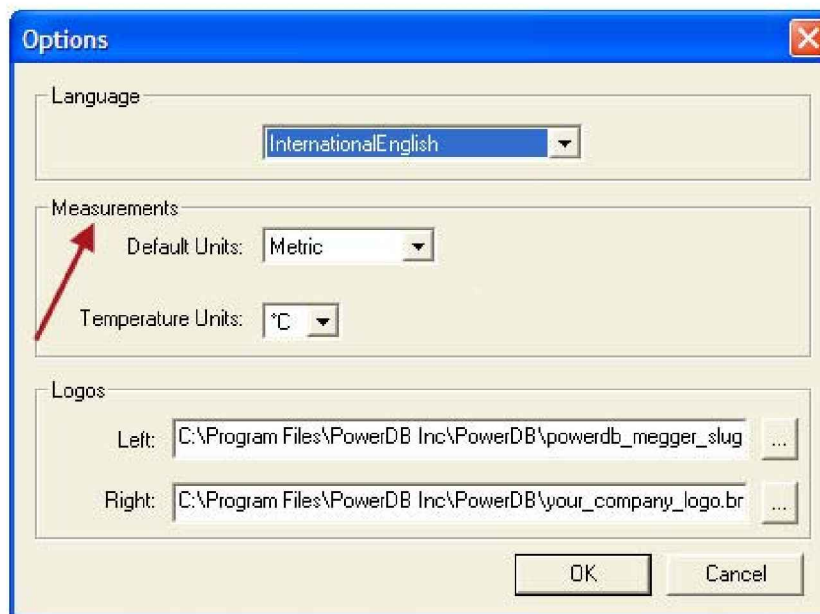

10. ADDITIONAL NOTES

- a. Additional forms can be filled out by repeating steps 2, 3 and 6.
- b. Forms can be printed with the *File>Print* menu item, or type *CTRL+P*, or press the *Print* toolbar button.
- c. A help guide may be found in the *Help>PowerDB Lite Help* menu item.

Frequently Asked Questions (FAQ's)

1. Can I change the forms?

No. You must have the full version of PowerDB to change forms.

2. Can I synchronize forms to a database?

No. You must have the full version of PowerDB for database support and to synchronize multiple field databases to a single master database.

3. Can I import PowerDB Lite files into PowerDB?

Yes. You can use the *File>Import* menu item in PowerDB to import files from PowerDB Lite.

7

Service

Maintenance

Maintenance should be performed only by qualified persons familiar with the hazards involved with high-voltage test equipment. Read and understand Section 2, *Safety*, before performing any service.

Routine maintenance is required for the MTO test set.

The appearance of the MTO test set can be maintained by occasionally cleaning the case, panel and cable assemblies.

1. Clean the outside of the carrying case with detergent and water. Dry with a clean, dry cloth.
2. Clean the control panel with a cloth dampened with detergent and water. Do NOT allow water to penetrate panel holes, because damage to components on the underside may result. An all-purpose, household spray cleaner can be used to clean the panel. Polish with a soft, dry cloth, taking care not to scratch the display screen cover.
3. Clean the cables and mating panel receptacles with isopropyl or denatured alcohol applied with a clean cloth.
4. Inspect the cable assemblies occasionally to ensure they are in good condition.

Fuse Replacement

The electronic circuits in the MTO test set are protected by two mains fuses. Fuse replacement is indicated if the electronic circuits do not function. Refer any fuse replacement to qualified personnel. To avoid electric shock and fire hazard, use only the fuses specified in Section 8, *Parts List and Optional Accessories* that are identical in respect to type, voltage rating, and current rating. Note that 2 spare fuses are included with each MTO.



WARNING
Before replacing the fuses, disconnect the power input plug from the live power source.

To replace fuse(s), proceed as follows:

1. Disconnect the power cord from the MTO test set.
2. Using a small flathead screwdriver, carefully remove the fuse holder of the input power module installed on the right side of the MTO test set front panel.
3. Remove and properly dispose of blown fuse(s).
4. Install new fuse(s) making sure to use the type specified in Section 8.
5. Reinstall the fuse holder in its receptacle in the input power module. Connect the power cord to the MTO test set and to an energized power source. If the electronic circuits still do not function properly, contact the factory for service.

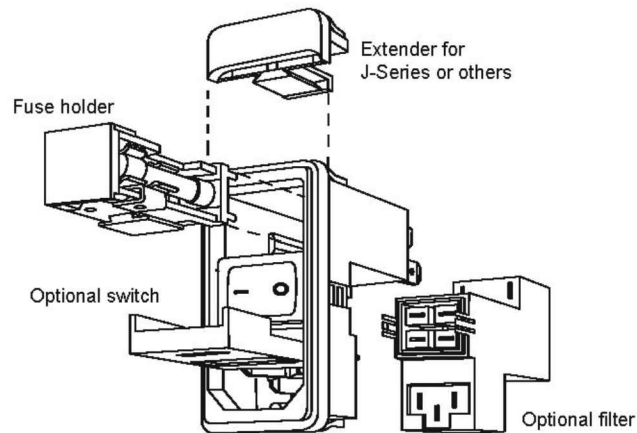

Calibration

A complete performance and calibration check should be made at least once every year. This will ensure that the MTO test set is functioning and calibrated properly over the entire measurement range. The MTO calibration is performed on each new or repaired unit before sending it to a customer. There is a special MTO final calibration procedure which requires a NIST-traceable test equipment to be used. As a result of such calibration procedure, each MTO test set may be NIST certified.

Repairs

Any service or repair of this equipment should only be performed by qualified persons who are aware of electrical hazards and the necessary precautions required to prevent injury.

Megger offers a complete Repair and Calibration Service and recommends that its customers take advantage of this service for routine maintenance or in the event of any equipment malfunction.

In the event that Service is required, contact your Megger representative for a product Return Authorization (RA) number and shipping instructions.

Ship the product prepaid and insured and marked for the attention of the Megger Repair Department. Please indicate all pertinent information, including catalog number, serial number, and problem symptoms.

ERROR CODES

MTO comes with a wide range of error codes to assure unit is working properly and track down problems in a systematic manner. When an error code occurs, the first thing to do is acknowledge the error by pressing enter and repeating the test. If the error persists, review the possible causes and determine if you can resolve the problem on site. If the basic cause a ruled out, contact Megger for additional assistance. Bold Error codes are quite common with the possible causes defined.

CODE	Error Description	Possible Cause
ESd	ESD is pushed down	Button is pushed down, internal cable is disconnected, internal hardware failure
IntLoc	Interlock interface is open	Interlock Jumper removed, attached interlock circuit broken, internal cable disconnected
1XX	<i>Ethernet and top panel errors (MTO210 ONLY)</i>	
101	No link between top panel and lower acquisition board	
102	Ethernet communication failed	
110	Current selection switch error	
111	Function Mode switch error	
112	Storage Mode Switch errors	
113	I2C BUS error	
114	LCD I2C bus error	
115	LED I2C bus error	
116	MUX I2C bus error	
117	EEPROM failure	
2.0	<i>Initialization error</i>	
201	ADC internal zero calibration failure	
202	ADC internal full-scale calibration failure	

CODE	Error Description	Possible Cause
203	Onboard 5 volt supply out of range, too high	
204	Onboard 10 volt out of range, too high	
205	Onboard 28 volt out of range, too high	
206	VICOR power supply temperature is out of range	
207	Discharge circuit temperature is out of range	
208	2.5V reference is out of range	
209	Zero reference is out of range	
210	25V reference is out of range	
211	VICOR power supply failed to regulate at 5 volts	
212	VICOR power supply failed to regulate at 20 volts	
213	VICOR power supply failed to regulate at 40 volts	
214	EsD	
215	VICOR power supply control loop circuit failed	
216	Too much voltage ripple for the 5 volt supply	
217	Too much voltage ripple for the 10 volt supply	
218	Too much voltage ripple for the 28 volt supply	
221	Too much voltage ripple for the 2.5 volt reference	
222	Too much voltage ripple for the 25 volt	

CODE	Error Description	Possible Cause
	reference	
223	Too much voltage ripple for the VICOR power supply at 5 volts	
224	Too much voltage ripple for the VICOR power supply at 20 volts	
225	Too much voltage ripple for the VICOR power supply at 40 volts	
226	UNDER status input failed	
227	OVER status input failed	
228	EEPROM byte writing error	
229	EEPROM byte reading error	
230	EEPROM is uninitialized	
231	Discharge temperature too much ripple	
232	VNOISE voltage out of range	
233	VNOISE voltage too much ripple	
234	VICOR power supply failed at 5v, voltage too high	
235	VICOR power supply failed at 5v, voltage too low	
236	VICOR power supply failed at 20v, voltage too high	
237	VICOR power supply failed at 20v, voltage too low	
238	VICOR power supply failed at 40v, voltage too high	
239	VICOR power supply failed at 40v, voltage too low	
240	VICOR power supply failed at loop test, voltage too low	

CODE	Error Description	Possible Cause
241	Onboard 10v out of range, voltage too low	
242	Onboard 28v out of range, voltage too low	
243	Discharge temperature is out of range, too high	Unit overheated, fans filters clogged, fans not working, overuse, extremely hot test conditions
244	VICOR temperature is out of range, too high	Unit overheated, fans filters clogged, fans not working, overuse, extremely hot test conditions
245	VNOISE voltage out of range, too low.	
246	VICOR temperature too much ripple	
3.0	<i>ADC_ERROR</i>	
301	ADC reading times out or ADC locks up	
302	Internal error. Communication with ADC failed.	
303	ADC sample rate setting failed	
304	ADC internal zero cal failed	
305	ADC internal full-scale calibration failed	
306	ADC cannot be restored back to normal mode	
307	ADC channel 1 selection failed	
308	ADC channel 2 selection failed	
309	ADC channel 3 selection failed	
310	Too much noise/ripple on ADC readings	
311	ADC failed, initialization	
312	ADC failed, run time	
313	ADC locks up, can not read	

CODE	Error Description	Possible Cause
314	ADC channel 4 failed	
4.0	<i>HARDWARE_ERROR</i>	
401	Discharge takes too much time	
402	VICOR protection failed, OVER is too long or too short to reset	
403	VICOR protection failed, OVER is too long or too short to set	
404	VICOR fast protection failed, OVER is too long or too short to reset	
405	VICOR fast protection failed, OVER is too long or too short to set	
406	Current Regulation failed at DAC=0	
407	Current Regulation failed at 10mA range	
408	Current Regulation failed at 100mA range	
409	Current Regulation failed at 1A range	
410	Current Regulation failed at 10A range	
411	Current output not high enough	
412	Too much ripple for Lamp On	
413	Too much ripple for Lamp Off	
414	Test Lamp voltage is too low	
415	Test Lamp voltage is too high	
416	Warning Lamp test failed	
417	Remote lamp test failed	
418	Relay test K1 on and K2 on failed	
419	Relay test K1 off test failed	

CODE	Error Description	Possible Cause
420	Relay test K2 off test failed	
421	Relay test K3 on and K4on failed	
422	Relay test K3 off test failed	
423	Relay test K4 off test failed	
465	OVER and UNDER failed during winding resistance test	
466	Current calibration failed during winding resistance test	
467	Voltage calibration failed during winding resistance test	
468	Received abort signal	
469	System zero cal failed during current regulation	
470	No current setting has been set for current control.	
471	Current is flat or dropping while charging	Current leads not connected
472	Break before make error	Lead removed during testing. >10% current change during testing.
473	H1+ failed, Vrelay3 failed	
474	X3+ failed, K9 failed	
475	I-SENSE failed	
476	Auto-range, resistance is too high	
477	Auto-range, current failed	
478	Auto-range, current standard deviation too high	
479	Auto-range, voltage is too low	

CODE	Error Description	Possible Cause
480	Current = 0	
481	Over didn't stay set for normal transistor protection test	
482	Over didn't stay set for fast transistor protection test	
483	Transistor protection med-low failed, OVER is too short to reset	
484	Transistor protection med-low failed, OVER is too short to set	
485	Fast transistor protection high failed, OVER is too short to reset	
486	Fast transistor protection high failed, OVER is too long to set	
487	Fast transistor protection high failed, OVER is too short to set	
488	Current Regulation failed at 10mA range, too low	
489	Current Regulation failed at 100mA range, too low	
490	Current Regulation failed at 1A range, too low	
491	Current Regulation failed at 10A range, too low	
492	Relay K1 and K2 failed, current too low	
493	Relay K3 and K4 failed, current too low	
494	ESD Abort signal encountered	Switch pushed down during test

8

Parts List and Optional Accessories

Item	Cat. No.
Transformer Ohmmeter 120/230 volt, 50/60 Hz input	MTO210
<u>INCLUDED ACCESSORIES</u>	
V1 Potential lead set, 60 ft (18 m)	2000-700
V2 Potential lead set, 60 ft (18 m)	2000-701
Current lead set, 60 ft (18 m)	2000-702
Shorting lead, 30 ft (9 m) [1]	2000-703
Ground lead, 15 ft (4.6 m) [1]	4702-7
Remote trigger switch	30915-220
AC power cord (IEC60320-C13 to US standard)	17032
AC power cord (IEC60320-C13 to Schuko CEE 7/7)	17032-13
Serial Data Cable	CA-RS232
In-lid Quick Start Guide	37178
Canvas carrying bag (for leadsets)	30915-211
Instruction manual	ATVMMTO210
PowerDB LITE software	DB0001
Fuse 3.15A, 250V, 5x20mm, SLO BLOW	27708-7
Fuse 6.3A, 250V, 5x20mm, SLO BLOW	90001-167
<u>OPTIONAL ACCESSORIES</u>	
Beacon strobe light	37181
Printer (includes battery/line powered serial thermal printer, printer interface cable)	
120 V, 60 Hz	1001-390
230 V, 50 Hz	1001-401
Foam-lined transit case	37009
PowerDB (full version) software, 1st machine license, soft key	DB1001
PowerDB (full version) software, 1st machine license, USB dongle	DB1001S

Megger.

9

Specifications

INPUT	120/230 V, 50/60 Hz, 750 VA
OUTPUT	
User Selectable Current Ranges:	up to 10 mA up to 100 mA up to 1 A up to 10 A
Test Voltage:	up to 50 Vdc
RESISTANCE MEASUREMENT/DISPLAY	
Resistance:	@ 10A 1 $\mu\Omega$ to 2 Ω res. 0.1 $\mu\Omega$ @ 1.0A 10 $\mu\Omega$ to 20 Ω res. 1.0 $\mu\Omega$ @ 100mA 100 $\mu\Omega$ to 200 Ω res 10 $\mu\Omega$ @ 10mA 1.0 m Ω to 2000 Ω res 0.1 m Ω
Accuracy:	$\pm 0.25\%$ reading, $\pm 0.25\%$ full scale
Resolution:	4 digits
Displays	Two 1" high, 6 character, 7-segment, LCDs One 0.71" high, 6 character, 7-segment, LCD
PRINTER	Via RS-232 port
USER INTERFACE	B&W numeric displays, keypad
COMPUTER INTERFACE (for downloading results)	Via RS-232 port
INTERNAL DATA STORAGE	Up to 2,000 data sets (256Kbytes)
ENVIRONMENTAL	
Operating:	14° F to 122° F (-10° C to 50° C)
Storage:	5° F to 158° F (-15° C to +70° C)
Relative Humidity:	0-90% non-condensing
DIMENSIONS	8.5 H x 21.5 W x 13 D (216 H x 546 W x 330 D mm)
WEIGHT	Net 29 lb (13.1 kg)

Megger.